



AALBORG UNIVERSITY
DENMARK

Aalborg Universitet

CLIMA 2016 - proceedings of the 12th REHVA World Congress

Heiselberg, Per Kvols

Publication date:
2016

Document Version
Publisher's PDF, also known as Version of record

[Link to publication from Aalborg University](#)

Citation for published version (APA):
Heiselberg, P. K. (Ed.) (2016). CLIMA 2016 - proceedings of the 12th REHVA World Congress: volume 3. Aalborg: Aalborg University, Department of Civil Engineering.

General rights

Copyright and moral rights for the publications made accessible in the public portal are retained by the authors and/or other copyright owners and it is a condition of accessing publications that users recognise and abide by the legal requirements associated with these rights.

- ? Users may download and print one copy of any publication from the public portal for the purpose of private study or research.
- ? You may not further distribute the material or use it for any profit-making activity or commercial gain
- ? You may freely distribute the URL identifying the publication in the public portal ?

Take down policy

If you believe that this document breaches copyright please contact us at vbn@aub.aau.dk providing details, and we will remove access to the work immediately and investigate your claim.

Zoo-technical application of Ground Source Heat Pumps: a pilot case study

Adriana Angelotti^{#1}, Luca Alberti^{*2}, Matteo Antelmi⁺³, Giovanni Formentin^{°4}, Cesare Legrenzi^{°5}

*#Dipartimento di Energia, Politecnico di Milano
v. Lambruschini 4, 20156 Milano, Italy*

¹adriana.angelotti@polimi.it

** Dipartimento di Ingegneria Civile Ambientale, Politecnico di Milano
P.zza L. da Vinci 32, 20133 Milano, Italy*

²luca.alberti@polimi.it

³matteo.antelmi@polimi.it

°Tethys Srl, v.le Lombardia 11, 20131 Milano, Italy

⁴giovanni.formentin@tethys.srl

⁵cesare.legrenzi@tethys.srl

Abstract

Ground Source Heat Pumps are energy-efficient HVAC systems usually adopted in residential and commercial buildings. However the control of the thermal environment is required not only in spaces occupied by people, but also in intensive breeding farms, in order to maintain healthy conditions and to increase productivity. In the Italian livestock breedings, heating is usually provided by means of gas or Diesel burners directly installed in the stable. An important part of the heating load is due to the large ventilation rates required for the livestock wellbeing. Cooling is either absent or achieved by evaporative systems that also increase the humidity level in the stables, thus requiring even larger ventilation rates. Therefore the applicability of geothermal heating and cooling in breeding farms was analysed in a research project co-funded by the Lombardy Region and the Italian Ministry of Research and Education. A pilot system for heating, cooling and ventilation was designed and installed in a piglet room at the Experimental and Didactic Zoo-technical Center of the University of Milan. Five Borehole Heat Exchangers (BHEs), installed down to a depth of 60 meters into an alluvial aquifer, were coupled with a Ground Source Heat Pump. The heat pump provides heating and cooling to an Air Handling Unit, including a Heat Recovery system. A monitoring system was installed in order to measure comfort conditions in the piglet room, operating conditions and energy consumption of the HVAC system, together with the spreading of the thermal plume in the ground. In this paper the results of a monitoring campaign carried out in a typical winter period are presented and discussed. The overall energy efficiency of the system, expressed in terms of a COP, results to be equal to 4.04. A comparison between the pilot HVAC system and a traditional one is also carried out, showing that the proposed solution can provide over 40% primary energy saving. Following, cost savings in energy bills for farmers are found, although the ratio between electricity cost and fuel cost is a key parameter.

Keywords – Ground source heat pump; heat recovery; comfort; zoo-technical; aquifer.

1. Introduction

The use of energy in a farm can be classified into direct (i.e. energy related to animal housing) and indirect (i.e. energy used for the production and the transport of materials used in a farm, e.g. feed and machinery) [1]. The main direct uses of energy in pig housing areas are lighting, heating and ventilation. Thermal environment and indoor air quality control are indeed required not only in spaces occupied by people, but also in intensive breeding farms, in order to maintain healthy conditions and to increase productivity.

According to IPPC document by EU Commission [2], in Italy fossil fuels and electricity are the energy fuels consumed in a pig farm. Depending on the farm size, fossil fuels represent 66-74% of the total energy consumption and electricity represents 34-26%. The annual total energy consumption per year per sow is 1314 kWh/(yr.sow).

In this framework the EcoZoo research project [3] was promoted, funded by the Italian Ministry of Education and Research and by the Lombardy Region. The EcoZoo project aims at testing the applicability to zoo-technical farms of HVAC systems based on Ground Source Heat Pumps (GSHPs), increasing at the same time energy efficiency in the farms and comfort conditions for animals.

The project started with a survey on energy uses and fuels consumption in livestock breeding farms in Lombardy. It was found that in zoo-technical farms heating is usually provided by means of gas or Diesel burners directly installed in the stables. An important part of the heating load is related to the large ventilation rates required for removing the pollution emitted by the animals and for the livestock wellbeing. Cooling is either not provided or achieved by evaporative systems that also increase the humidity level in the stables, thus requiring even larger ventilation rates.

Secondly within the EcoZoo project a pilot system for a piglet stable was designed, installed and monitored. The Padana plain where the system was located is rich in groundwater. The influence of groundwater flow on GSHPs performance and the thermal perturbation in the aquifer due to GSHPs operation are an important and actual research issue [4]. Therefore, hydrogeological conditions were specifically investigated within the project and some additional wells were realized in order to monitor heat transfer in the aquifer. The present paper describes the main characteristics of the HVAC system and reports the results of a monitoring campaign performed during winter 2015.

2. The pilot system

The pilot HVAC system was installed in a post-weaning piglets room located in Lodi, at the Experimental Didactic Zoo-technical Center of the University of Milan. The room is located in a large shed and is dedicated to experimental and didactic activities of the Veterinary Medicine School, mainly related to animals feeding. It is 43 m² large and it can host up to 100 piglets. Typically, the piglets arrive when they weight about 6 kg and leave the room after 6-8 weeks when they weight about 34 kg. The comfort temperature required decreases as the piglets grow, being about 28°C at the beginning of their stay in the Center and about 22°C at the end. At the same time a

ventilation rate of about 1000 m³/h or 8 ACH is required in order to remove pollutants emitted by the piglets. Before the EcoZoo project, a 16 kW fan gas burner and two fans for the air suction installed in the piglets room provided the necessary heating and ventilation in winter. During summer, no cooling system was available and some mitigation was obtained by running the fans at the maximum velocity.

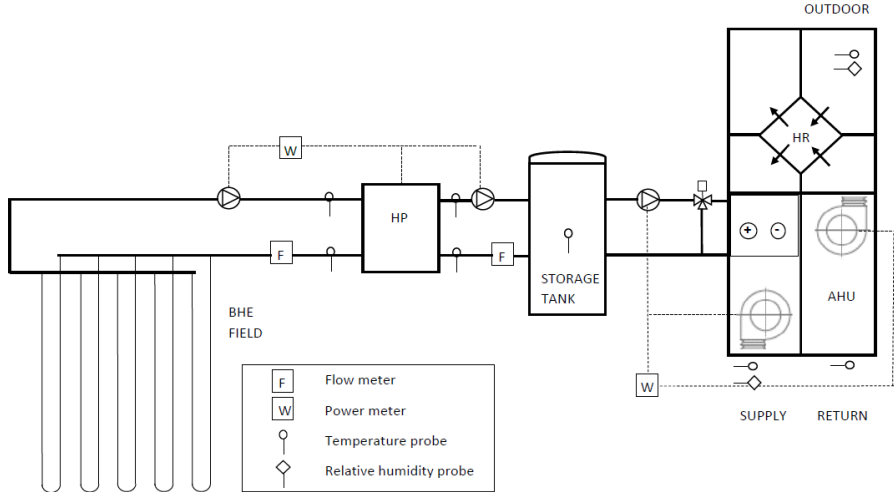

Fig. 1 EcoZoo system

The HVAC system installed within the EcoZoo project (Fig. 1) consists in a Ground Source Heat Pump (heating capacity 14.4 kW at 40/45 °C on the supply side and 3/0 °C on the ground side; cooling capacity 15.9 kW at 10/15 °C on the supply side and 30/35 °C on the ground side). The warm/cold water produced by the heat pump is stored in a 300 lt water tank supplying the heating/cooling coil of an Air Handling Unit (AHU). Due to the large ventilation rates required, the AHU has a heat recovery heat exchanger (nominal efficiency 78%). The AHU nominal ventilation flow rate is equal to 1200 m³/h.

The Ground Source Heat Pump (GSHP) is coupled to a Borehole Field made up of 5 boreholes with a single U-pipe 60 m deep in the ground. The layout of the boreholes (see Fig. 2) was chosen after a detailed hydrogeological investigation. Following a literature research about the hydrogeological setting of the area, a field survey was carried out to select all the available wells and piezometers in a radius of 1 km around the zoo-technical center in order to collect groundwater level measurements. Therefore, a water table map of the shallow aquifer was initially interpolated at municipal scale, showing a main flow direction from South-West to North-East. Next, by measuring the hydraulic heads at site scale into the 4 micro-piezometers specifically realized for the EcoZoo project (see mp1 - mp4 in Fig. 2), the same groundwater flow direction (SW –

NE) was assessed. Hence, in order to maximize the heat exchange efficiency, 4 out of 5 BHEs were disposed on a line forming an angle of about 45° with the groundwater flow direction (see BHE1 - BHE4 in Fig. 2). Only one borehole, namely BHE5, was disposed downstream of another, to allow verifying the impact of groundwater flow.

Some additional piezometers were also realized nearby BHE1. In particular P1 is 60 m deep and located 2 m downstream BHE1.



Fig. 2. Location of the piglets room, of the borehole field, of the piezometers and micro-piezometers. The groundwater flow direction is shown by the arrow.

3. Thermal and hydrogeological in situ characterisation

A geognostic survey performed on piezometer P1 allowed characterizing the soil stratigraphy as a succession of fine and coarse deposits, with a clay layer about 3 meters thick and 30 m deep locally separating the shallow aquifer in two bodies. Adopting reference data for the thermal conductivity of different kinds of ground layers from literature [5], on the basis of the stratigraphy of the site, the average ground conductivity was estimated to be $(2.33 \pm 0.53) \text{ W}/(\text{m}\cdot\text{K})$. This literature estimate was compared with the outcomes of a 72 h long Thermal Response Test (TRT) performed on BHE4. In Fig. 3 the thermal conductivity derived from the TRT data analysis, based on the classical Line Source Model interpolation at increasing evaluation time, is reported. As discussed by Witte [6], when thermal conductivity increases with evaluation time, a significant groundwater flow is present. In our case the experimental thermal conductivity trend is not clearly converging. A longer TRT would have allowed

to better identify a possibly increasing trend. The ground thermal conductivity extracted from the TRT was 4.12 W/(m.K), a much larger value than any estimate based on literature (see again Fig. 3). Groundwater flow may have contributed to this mismatch, by introducing an additional heat transfer mechanism in the ground based on advection and leading thus to an overestimate of the thermal conductivity. Therefore from the TRT the evidence of a groundwater flow is derived, although a modest velocity is expected.

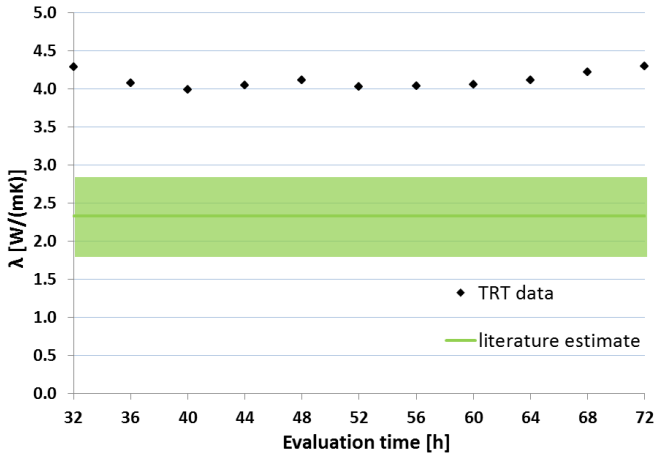

Fig. 3. Ground thermal conductivity from TRT versus evaluation time and literature estimate

Different subsequent field activities, i.e. pumping and slug tests, allowed to hydraulically typify the shallow aquifer. The pumping test performed into piezometer P2 pointed out a range of hydraulic conductivities varying from 10^{-4} m/s to 10^{-5} m/s. On the other hand, slug tests carried out in mp1- mp5 resulted in somehow higher values, namely from 10^{-3} m/s to 10^{-4} m/s. The latter range fits well inside the hydraulic conductivity values derived from literature concerning lithologies such as fine sand, medium sand or silty sand. These tests allowed to estimate a range, namely $10^{-7} - 10^{-6}$ m/s, for the Darcy velocity on the upper part of the shallow aquifer.

4. The monitoring system

A monitoring system based on a NI cDAQ data acquisition system and LabView was installed. The following probes were installed:

- 4 temperature sensors PT100 located at 10 m, 25 m, 40 m and 55 m from the surface into BHE1, BHE5 and P1, for a total of 12 sensors into the ground;

- 4 temperature sensors PT100 at the heat pump inlet/outlet on the ground and supply side;
- 2 electromagnetic flow meters measuring the water flow rate on the ground loop and on the supply loop of the heat pump;
- 4 thermocouples sensors measuring the outdoor, the supply, the room and the return air temperature;
- 2 air humidity sensors for room and external relative humidity;
- 2 air flow meters for the supply and return air flow rates;
- 2 power meters measuring the electrical power consumed by the heat pump and by the AHU separately.

Therefore the measurement system allows to:

- monitor thermal conditions in the boreholes and in the nearby aquifer;
- measure energy performance of the GSHP and of the AHU;
- monitor comfort conditions in the piglets room.

During the experimental campaign in Winter 2015 data were acquired every minute.

5. Experimental results

An experimental campaign of about 30 days was performed in March 2015. Following the piglets growth, the indoor set point temperature was initially set at 28°C and then gradually reduced, being 25°C at the end of the period. It has to be remarked that the set point has to be maintained 24 h a day and 7 days a week.

The typical behavior of the system is showed in Fig. 4 where the time interval between 5 a.m. and 5 p.m. of a reference day is shown. It can be noticed that on the ground side, the heat pump receives water at about 7-8°C and returns water at about 11-12°C. From the monitored flow rate and inlet/outlet temperature difference, the heat rates exchanged on the source side (Q_g) and the supply side (Q_s) of the heat pump are calculated. The heat pump extracts from the ground approximately 12 kW, supplies about 16 kW to the storage tank and consumes about 5 kW. The heat pump switches on whenever the return water temperature from the storage tank drops below the set point, namely 47°C, with a dead band of 3°C. As a consequence, it operates with an on/off cycling of about 20-25 minutes.

Fig. 5 reports the operation of the AHU on the same day, by showing the outdoor, the supply, the return and the indoor temperature. From the measured supply air flow rate and temperature difference between supply and outdoor air, the heat rate provided by the AHU, namely Q_{AHU} , is calculated and shown, together with the measured power consumption W_{AHU} . As the outdoor temperature increases during the day, the supply air temperature is modulated by the system regulation, and the heat rate provided by the AHU decreases. The fans operate continuously to provide the necessary air changes and thus the AHU electrical consumption has a constant value of 0.6 kW.

By taking into account the whole 30 days period, an energy balance of the EcoZoo system is performed and reported in Fig. 6. The average heat pump COP, calculated as the heating energy produced by the heat pump (4433 kWh) over the electricity consumption (1454 kWh), is found to be 3.06.

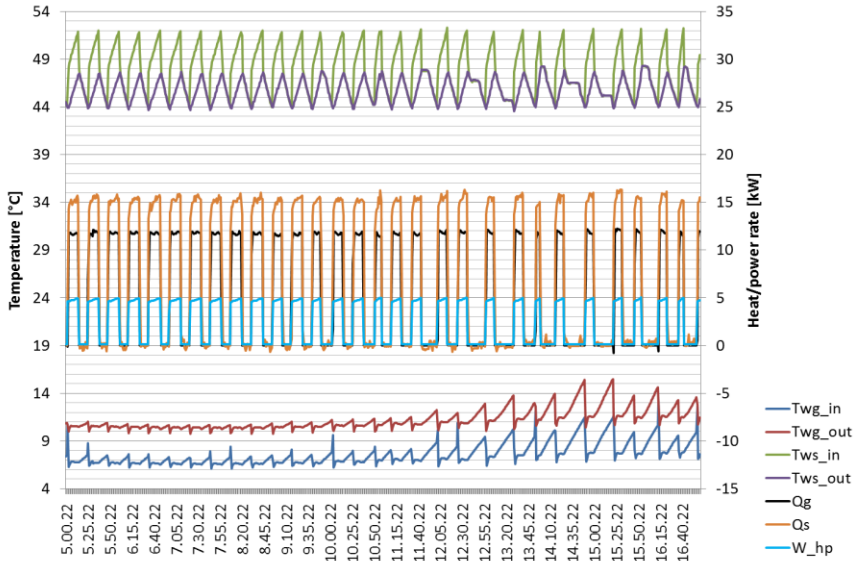

Fig. 4. Heat pump operation on a typical day: water temperatures on the ground and on the storage sides, heat rate from the ground Q_g and to the storage Q_s , power rate consumed W_{hp}

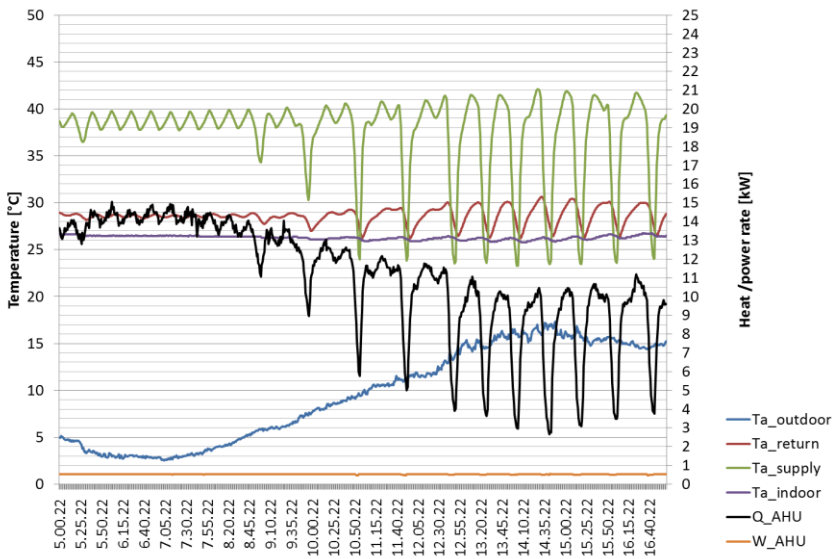

Fig. 5. AHU operation on a typical day: air temperatures, heat rate Q_{AHU} and power rate consumed W_{AHU}

The overall system efficiency, namely the ratio of the heating energy delivered (7382 kWh) over the total electricity consumed by the heat pump and the AHU (1928 kWh), is found to be 4.04. The heat recovery energy is not directly measured and thus is here approximately estimated as the difference between the thermal energy delivered by the AHU and the sum of the heating energy produced by the heat pump and the electricity consumed by the AHU. Although this is a rough estimate, it allows to point out the relevant role played by the heat recovery unit (see again Fig. 6).

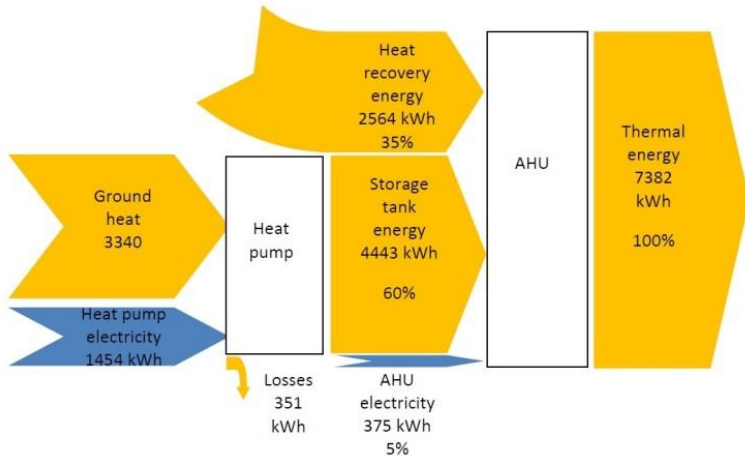

Fig. 6. EcoZoo system energy flows

These figures allow performing a comparison between the EcoZoo system and a traditional HVAC system typically adopted in zoo-technical farms. In the case study, the gas burner fan system installed in the piglets room and previously adopted by the Center was chosen as reference system. Since the gas burner is placed inside the piglets room, a 100% efficiency in converting gas energy into useful heat is assumed. According to the data sheets, the fans consume 180 W. In the comparison the two systems are assumed to provide the same heating energy and the same air changes. Primary energy conversion factors adopted are 1.05 and 2.42 for gas and electricity respectively, according to present Italian regulation. As shown in Fig. 7, the EcoZoo system would consume 45% less primary energy than the traditional system. By considering the energy costs for non-domestic consumers in 2014 as reported in [7], namely 0.31 €/kWh for electricity and 0.79 €/m³ for gas, the EcoZoo system would allow saving 12% of the energy costs compared to the traditional system.

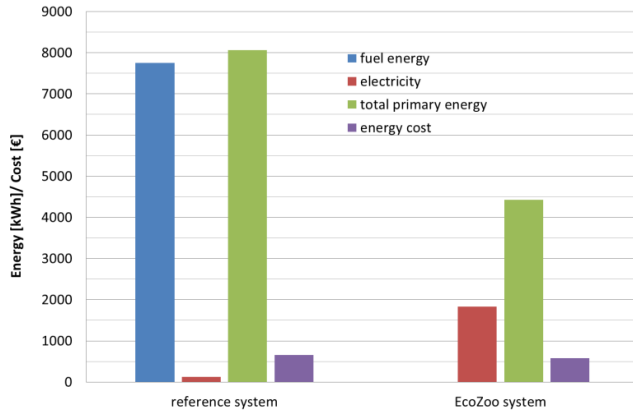

Fig. 7. Comparison between EcoZoo and reference HVAC system: primary energy and energy cost

The thermal perturbation produced by the GSHP operation in the deeper aquifer is now analysed. In Fig. 8 the temperature in borehole BHE1 and in the nearby piezometer P1 at 40 m and 55 m during a 140 days monitoring between January and June 2015 is reported. At the beginning of this long period, the undisturbed condition can be identified as a temperature between 14 and 15 °C. As the GSHP is switched on, a temperature drop of about 5°C is quickly produced in the borehole. However, as the system operation goes on, the temperature perturbation tends to decrease. This is probably because the heating demand of the building decreases as winter proceeds and because the borehole volume is regenerated by the surrounding ground. When the GSHP system is switched off, about 1 week is needed to recover the unperturbed value. The influence of the GSHP can be noticed also in the piezometer 2 m downstream, although the temperature there decreases by less than 1°C. A different groundwater velocity at 40 m and 55 m can also be remarked.

6. Discussion and conclusions

The GSHP coupled to the AHU with Heat Recovery has proved to be an energy efficient solution for the chosen case study. Although a small-scale system was developed, its energy uses and consumptions are representative of the typical piglets stable. Moreover, the results state that the system could be successfully applied where control of the thermal environment is critical, such as in poultry farms. The comparison with a more traditional HVAC system points out the great advantage in terms of primary energy savings. The smaller cost savings are due to the high ratio between electricity and gas costs of the Italian market. In countries where the cost of electricity is significantly lower, cost savings become consequently appreciable.

In the given case study, the temperature perturbation induced by the GSHP operation in the boreholes is significant, but decreases rapidly away from the boreholes.

A possible contribution to this result comes from the preliminary hydrogeological survey, which allowed to place the borehole heat exchangers in a layout that avoids the overlapping of thermal plumes. The impact of this choice will be better highlighted by the long-term monitoring of the temperature evolution in the boreholes and in the aquifer, especially from the comparison between BHE1 and BHE5. In addition monitored data on the aquifer temperature evolution will be used for future developments, such as the calibration of a numerical model for heat and mass transport in the subsoil, aimed at determining the influence of groundwater velocity on the system performance.

A part of the ongoing study, led by researchers at the Veterinary Medicine School, aims at assessing potential changes in animal wellbeing deriving from the improved ambient conditions.

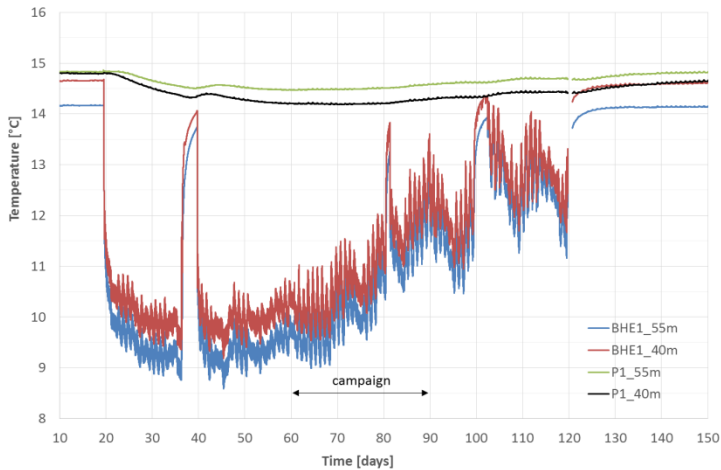

Fig. 8. Temperature into Borehole 1 and into Piezometer 1 at 40 m and 55 m versus time

References

- [1] M. Meul, F. Nevens, D. Rehuel, G. Hofman. Energy use efficiency of specialized dairy, arable and pig farms in Flanders. *Agriculture, Ecosystems and Environment* 119 (2007) 135-144.
- [2] European Commission. Integrated pollution prevention and control – reference document on best available techniques for intensive rearing of chicken and pigs (2003).
- [3] Progetto EcoZoo. Relazione tecnica finale. 2015
- [4] A. Angelotti, L. Alberti, I. La Licata, M. Antelmi. Energy performance and thermal impact of a Borehole Heat Exchanger in a sandy aquifer: influence of the groundwater velocity. *Energy Conversion and Management* 77 (2014) 700-708.
- [5] UNI 11466. Heat pump geothermal systems. Design and sizing requirements. UNI, Milano (2012).
- [6] H.J.L.Witte. Geothermal Response Tests with Heat Extraction and Heat Injection: examples of application in research and design of geothermal ground heat exchangers. *Europäischer workshop über Geothermische Response Tests*, EPFL, Lausanne, 25- 26 Oct. 2001.
- [7] Autorità per l'Energia Elettrica, il Gas e il Sistema Idrico. Relazione annuale sullo stato dei servizi e sull'attività svolta. Istituto Poligrafico e Zecca dello Stato (2015).