



13th International Conference on Greenhouse Gas Control Technologies, GHGT-13, 14-18
November 2016, Lausanne, Switzerland

Integration of Ca-Looping systems for CO₂ capture in cement plants

M. Spinelli^a, I. Martínez^a, E. De Lena^a, G. Cinti^b, M. Hornberger^c,
R. Spörl^c, J.C. Abanades^d, S. Becker^e, R. Mathai^e, K. Fleiger^f, V. Hoenig^f,
M. Gatti^a, R. Scaccabarozzi^a, S. Campanari^a, S. Consonni^a, M.C. Romano^{a*}

^aPolitecnico di Milano, Department of Energy, Via Lambruschini 4, 20156 Milano, Italy

^bCTG Italcementi Group, Via Camozzi 124, 24121 Bergamo, Italy

^cInstitute of Combustion and Power Plant Technology (IFK), University of Stuttgart, Pfaffenwaldring 23, 70569 Stuttgart, Germany

^dCSIC-INCAR, Francisco Pintado Fe 26, 33011 Oviedo, Spain

^eIKN GmbH, Herzog-Erich-Allee 1, 31535 Neustadt, Germany

^fVDZ gGmbH, Tannenstrasse 2, 40476 Duesseldorf, Germany

Abstract

Ca-Looping (CaL) has been demonstrated as a promising technology for CO₂ capture in coal-fired power plants. A promising application is also in cement plants, where the CaO-rich material purged from the CaL process can replace part or all of the raw material used for clinker production. The aim of this work is to investigate two process integration options of the CaL system based on fluidized bed and entrained flow reactors in a clinker burning process. The main advantages, constrains and research questions of the two configurations are discussed, and the mass and energy balances of the whole processes are detailed and analyzed.

© 2017 The Authors. Published by Elsevier Ltd. This is an open access article under the CC BY-NC-ND license (<http://creativecommons.org/licenses/by-nc-nd/4.0/>).

Peer-review under responsibility of the organizing committee of GHGT-13.

Keywords: CO₂ capture; cement; Calcium-Looping; process modelling

* Corresponding author. Tel.: +39-02-2399-3846.

E-mail address: matteo.romano@polimi.it

Nomenclature

CaL	Calcium looping
CFB	Circulating fluidized bed
clk	clinker
E_{carb}	CO ₂ capture efficiency in the carbonator of the CaL
e_{CO_2}	Specific CO ₂ emissions
E_{eq}	Equilibrium CO ₂ capture efficiency in the carbonator of the CaL
EF	Entrained flow
eq	Equivalent (i.e. taking into account indirect primary energy consumptions and emissions from electricity exchanged with the grid)
F_0	Molar flow of CaCO ₃ in the fresh material fed to the calciner of the CaL process
F_{Ca}	Molar flow rate of CaO fed to the carbonator of the CaL process from the calciner
F_{CO_2}	Molar flow of CO ₂ fed to the carbonator of the CaL process
IL	Integration Level
P_{el}	Specific net electric consumption in the process
q	Specific primary energy consumption
th	thermal
X_{ave}	Maximum average conversion of CaO particles in the carbonator of the CaL

1. Introduction

The cement industry is one of the largest industrial sources of CO₂ emissions into the atmosphere, representing approximately 5% of global anthropogenic CO₂ emissions [1]. CaCO₃ is the most important raw material in the cement production industry, which inherently releases CO₂ when calcined to produce CaO and then clinker. In state-of-the-art dry clinker burning processes, CO₂ produced from CaCO₃ calcination represents about 60 % of the total CO₂ emissions, the remaining fraction being emitted from fuel combustion. In the framework of the H2020 CEMCAP project [2], different technologies for CO₂ capture in cement plants are being assessed and benchmarked, namely oxyfuel kiln, chilled ammonia, CO₂ membranes and Calcium Looping (CaL). This work focuses on the CaL process, which is based on the use of CaO as high temperature CO₂ sorbent. Two different process integration options, namely tail-end and highly integrated configurations, are assessed, based on conventional fluidized bed and novel entrained flow reactors respectively. The main advantages, constraints and research questions of the two configurations and reactor types are discussed by establishing and solving in detail the mass and energy balances of the two process routes.

2. Process description*2.1. Tail-end CaL configuration*

In the tail-end configuration, the CaL is not deeply integrated in the clinker burning line, but it is operated as an end of pipe CO₂ sorption unit. Fig. 1 shows a simple schematic of this configuration. As noticed, the integration between the cement plant and the CaL system is done through the flue gas from the cement kiln that is fed to the carbonator of the CaL system and through the CaO-rich solid purge from the CaL calciner, which replaces part of the limestone contained in the raw meal as source of Calcium for clinker production. The limited integration between the capture plant and the cement kiln makes this configuration particularly suitable for retrofitting.

In this configuration, both circulating fluidized bed (CFB) and entrained flow (EF) reactors can be used for the calciner and the carbonator of the CaL process. The selection of the fluid-dynamic regime mainly depends on the size of the limestone particles used in the CaL process, the gas velocities and gas/solid flow ratios. CFBs are more suitable for operating with particle diameters of around 100-250 μm , whereas EF reactors are more suitable for finer particles and higher velocities, as familiar in the cement industry where the average size of the raw meal particles

(d_{50}) is around 10-20 μm . CFBs represent the typical choice for post-combustion CaL systems, whose operation has been successfully demonstrated up to 1.7 MW_{th} -scale for application in power plants [3,4]. This type of reactor, for which there are minor uncertainties in the adaptability for application in cement plants, has therefore been selected for the tail-end configuration. The relatively large CaO particle size in the CaO-rich purge may impose an additional milling step together with the other raw material constituents. This will allow obtaining a proper size of the raw meal particles and a proper homogenization of the constituents, so as not to alter the quality of the final clinker. In the calculations performed, it is therefore assumed that the CaO-rich purge from the calciner of the CaL process is first cooled down in a direct gas-solid cooler, mixed with the additional limestone and additives and then milled to the typical particle size used in cement plants and fed to the clinker burning line. This configuration also allows using a conventional solid mixing system that guarantees the intimate mixing of the CaO-rich material from the CaL with additional CaCO_3 -rich minerals and corrective materials containing Al_2O_3 , Fe_2O_3 and SiO_2 that are needed to adjust the elemental composition to typical raw meals.

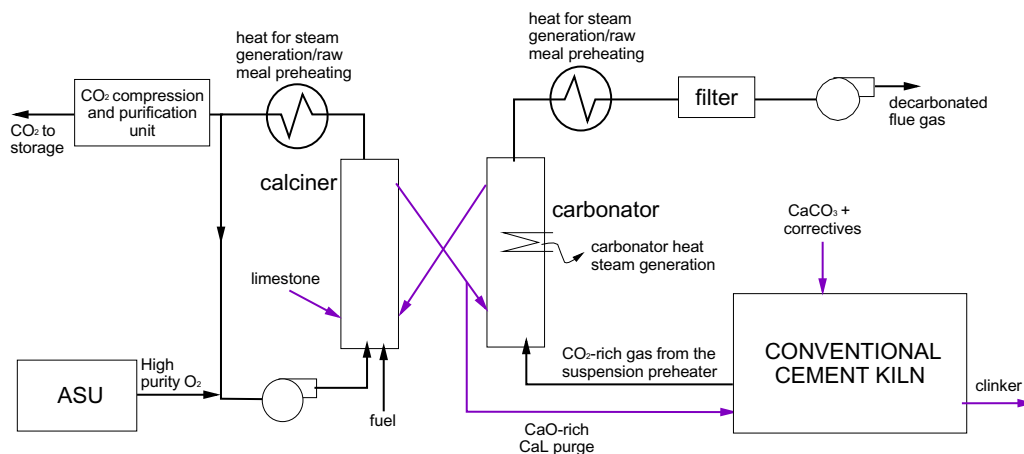

Fig. 1 Process flowsheet of the tail-end CaL process integration for CO_2 capture from cement plants

Concerning the CaL system operation, the carbonator reactor is operated at 650°C and the solids exiting this reactor are sent to the CaL calciner, where oxy-combustion of a fuel occurs at around $900\text{--}910^\circ\text{C}$ for providing energy needed for CaCO_3 calcination. High purity O_2 produced in an Air Separation Unit (ASU) is used as oxidant. High purity limestone is fed to the calciner of the CaL process. Its flow rate is controlled through the ratio F_0/F_{CO_2} that indicates the molar flow of fresh CaCO_3 fed to the CaL system per mole of CO_2 entering the carbonator. Looking to the CaL system depicted in Fig. 1, it can be noticed that the amount of CaCO_3 introduced in the CaL calciner is ultimately extracted from the calciner as CaO-rich purge and sent to the cement kiln. The *integration level* (IL) between the CaL and the cement kiln is therefore defined as the percentage of CaO entering the cement kiln with the CaO-rich purge of the CaL unit with respect to the total Calcium input. Calculations of this configuration have been done for three different ILs of 15, 20 and 25%, which correspond to F_0/F_{CO_2} of 0.11, 0.16 and 0.21 respectively. An additional parameter needed to solve the CaL balances is the sorbent circulation ratio $F_{\text{Ca}}/F_{\text{CO}_2}$, which determines the ratio between the CaO molar flow rate flowing into the carbonator reactor and the molar flow of CO_2 fed this reactor with the exhaust gas from the cement kiln. Due to the presence of a significant amount of CaO in the coal ashes (ash content in the coal is 16.5%wt., and the CaO content in the ash is 18.2%wt.), F_{Ca} refers exclusively to the Calcium originating from the limestone fed into the calciner with stream F_0 (i.e. without accounting for CaO in the coal ashes). In other words, it is assumed that the CaO from coal ash (up to 5% of the total CaO population in the assessed cases) is inactive as CO_2 sorbent.

The CFB carbonator model proposed by Romano [5] has been used for calculating the CO_2 capture efficiency as a function of the carbonator operating parameters. This reactor model is based on the model of Kunii and Levenspiel for CFBs [6], it includes the carbonation kinetic model proposed by Grasa et al. [7] for CaO particles and considers

the effects of coal ashes and sulfur species on the CO₂ separation efficiency. With the aim of comparing the results obtained with this reactor model, the ideal carbonator CO₂ capture efficiency has been also calculated, assuming that the CaO particles in this reactor achieve their maximum average conversion (X_{ave}). CO₂ capture efficiency in the carbonator in this case is therefore limited either by the equilibrium of the carbonation reaction (i.e. by the equilibrium CO₂ partial pressure in the gas phase at the carbonator temperature) or by the availability of circulating sorbent. The corresponding law is described by Eq.(1), where the maximum conversion X_{ave} is calculated according to the CaO capacity decay curve proposed by Grasa and Abanades [8] and with the statistical cycle number distribution discussed by Abanades [9].

$$E_{carb} = \min\left(\frac{F_{Ca,act} \cdot X_{ave}}{F_{CO_2}}, E_{eq}\right) \quad (1)$$

In Fig. 2, the CO₂ capture efficiency achieved in the carbonator of the CFB CaL system is depicted as function of the integration level IL and the sorbent circulation rate (F_{Ca}/F_{CO_2}). A total solids inventory of 1000 kg per m² of reactor cross-section is always maintained in the simulations. Higher sorbent make-up (corresponding to a high purge from the system and therefore a high integration level) and higher solid circulation increase the carbon capture rate. All the curves in Fig. 2 can be divided into two regions. In the first region (low F_{Ca}/F_{CO_2}) the capture efficiency is limited by the active sorbent availability. In this region, a steep CO₂ capture efficiency increase can be achieved by increasing solids circulation. In the second region (high F_{Ca}/F_{CO_2}) an asymptotic trend can be noticed, where carbon capture is limited by thermodynamic equilibrium (i.e. CO₂ partial pressure at the reactor temperature) and cannot be increased further by increasing solids circulation or sorbent make up. In the ideal cases, a sharp transition between the two zones can be observed. For the cases calculated with the carbonator model, a smooth transition is obtained, indicating that CO₂ capture is limited by kinetics and mass transport when active sorbent circulation is close to the stoichiometric amount. As far as the integration level is concerned, a higher sorbent make up reduces the fraction of inert material (i.e. ash from coal and CaSO₄) and the average number of carbonation-calcination cycles experienced by the active sorbent. This increases both the average reactivity of the solid population, which reduces the difference between the ideal and model CO₂ capture curves, and increases X_{ave} , which shifts the transition between the two zones to lower F_{Ca}/F_{CO_2} .

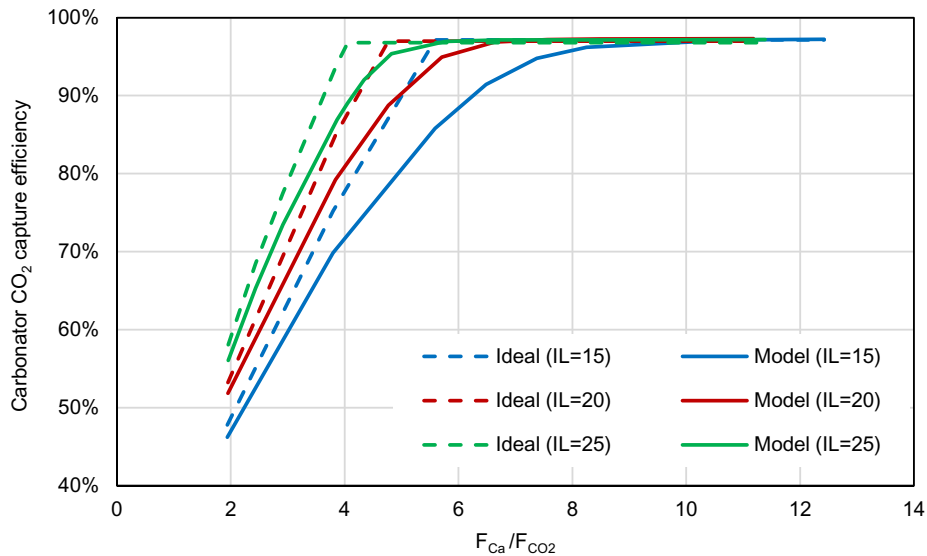

Fig. 2 Carbonator efficiency as a function of the ratio F_{Ca}/F_{CO_2} for different integration levels, as predicted with the carbonator model [5] (solid lines) and according to the ideal case equation (1) (dashed lines)

Based on the assumed gas superficial velocity at reactor outlet of 4 m/s, it has been calculated that for F_{Ca}/F_{CO_2} between 4 and 6, solid circulations were in the range of 8-17 kg/m²·s and of 4-7 kg/m²·s in the carbonator and the calciner respectively, which are of the order of typical operating conditions of commercial CFB combustors. At such conditions, CO₂ capture efficiencies between 70% and >95% are possible in the carbonator of the CaL system depending the IL, as can be observed in Fig. 2. For these reasons, this range of values for the ratio F_{Ca}/F_{CO_2} has been considered as an optimal operating window for the CaL integration scheme in Fig. 1.

In order to recover the excess heat available at different points of the CaL system in Fig. 1 (i.e. carbonator cooling, carbonator and calciner flue gases, CaL purge cooling), a heat recovery steam cycle has been considered. The steam cycle is a superheated cycle with no reheaters and two feed water heaters (including the deaerator), with live steam parameters of 100 bar and 530°C and a condensing pressure of 0.07 bar. Cycle configuration and steam parameters have been defined according to the expected technology for medium-size power plants, as results from the process simulations performed in this study (about 200 MW of thermal input).

2.2. Integrated CaL configuration

In the integrated CaL configuration, a tight integration between the CaL system and the cement plant is proposed according to the flowsheet shown in Fig. 3. The core idea of this configuration, which was originally proposed using entrained bed reactors in [10] is switching the pre-calciner of the cement plant to oxyfuel mode, so that it coincides with the calciner of the CaL system. In this way, CO₂ from fuel combustion in the calciner and from raw meal calcination is made available as concentrated CO₂ gas from this reactor. On the other hand, CO₂ released in the air-blown rotary kiln from the additional fuel combustion and residual raw meal calcination is captured in the CaL carbonator.

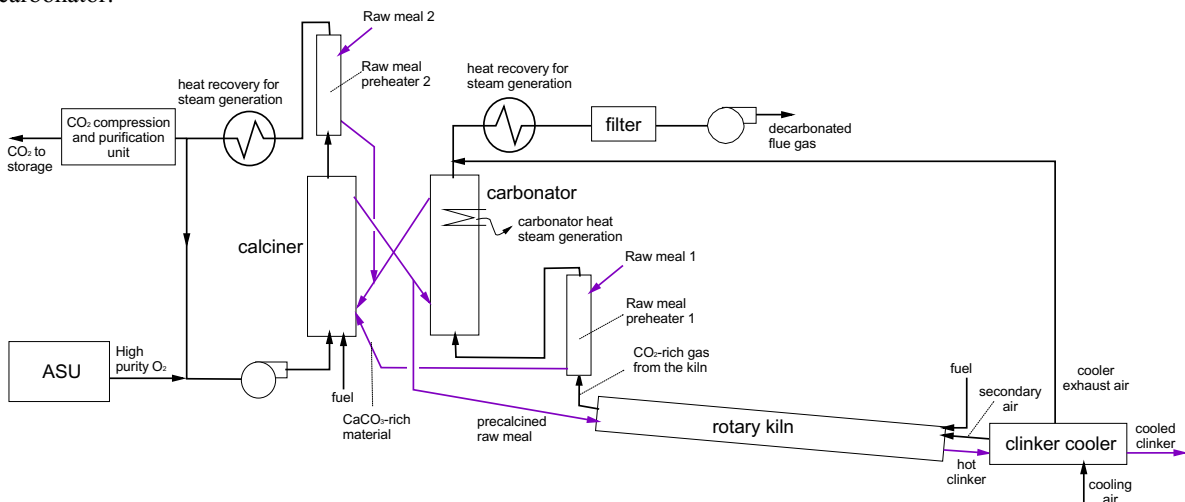

Fig. 3 Process flowsheet of the integrated CaL process configuration

Differently from the tail-end configuration, in this case the CaO-rich sorbent is constituted by the calcined raw meal used for clinker production, hence it contains also the alumina, ferritic and silica species that are normally included in the raw meal fed to the preheating tower. In addition, the sorbent particle size is lower ($\approx 10\text{-}20\ \mu\text{m}$ on average), which makes the adoption of entrained flow CaL reactors and their tight integration in the cement plant preheating tower the preferred option. As a result, the whole limestone flow rate fed to the cement kiln, as part of the raw material, contributes to the sorbent make up (i.e. integration level = 100%) resulting in F_0/F_{CO_2} of about 4, which is two orders of magnitude higher than the values commonly considered in post-combustion CaL applications. Before being introduced in the carbonator, the CO₂-rich gas coming from the rotary kiln is fed to a two-stage suspension preheater (indicated as 'Raw meal preheater 1' in Fig. 3), where a fraction of the raw meal is heated up before being fed to the calciner. This preheating section allows reducing the gas temperature and so

decreasing the carbonator cooling duty. The remaining fraction of the raw meal is preheated in a parallel preheating tower (i.e. 'Raw meal preheater 2' in Fig. 3), which is fed by the CO₂-rich gas leaving the oxyfuel calciner. At the preheater outlet, a fraction of the CO₂-rich gas is partially recycled to the calciner together with the pure O₂ coming from the ASU, whereas the remaining gas is sent to the purification and compression unit after proper cooling and water condensation. The CO₂-lean gases at the carbonator outlet are mixed with the cooler exhaust air from the clinker cooler and then cooled in a heat recovery/steam generation section.

Temperature in the calciner has been maintained at 900°C with the aim of ensuring enough driving force for calcination reaction to achieve the same calcination efficiency of 94.2% as in the reference plant without CO₂ capture. A fraction of the calcined material exiting the calciner is extracted from the CaL loop and sent to the rotary kiln, whereas the remaining material is sent to the entrained flow carbonator for reacting with the CO₂ in the rotary kiln exhaust gas. In this case, the carbonator has been calculated assuming a constant CO₂ capture efficiency of 80%, without considering a carbonator reactor model. The main reason for this approach is the absence of an accurate entrained flow reactor model for the carbonator and the uncertainty associated to the use of raw meal as sorbent in the CaL system. In particular, reactions between the different species in the raw meal leading to intermediate clinker phase formation may affect the reactivity of the CaO in the carbonation reaction. Investigations to be carried out within CEMCAP project [2] will allow answering these research questions. With the aim of solving the balances of the whole process shown in Fig. 3, the CaO conversion needed in the carbonator is calculated for every value of F_{Ca}/F_{CO_2} considered. Fig. 4 shows the CaO conversion in the carbonator to achieve the assumed 80% CO₂ capture efficiency and the solids to gas ratio at carbonator. In cement kilns, solid to gas ratio are normally below 1 kg/kg, which is less than what expected in the entrained flow carbonator (see Fig. 4). The fluid dynamic behavior of the reactor is therefore another research question that needs to be answered to validate the proposed process.

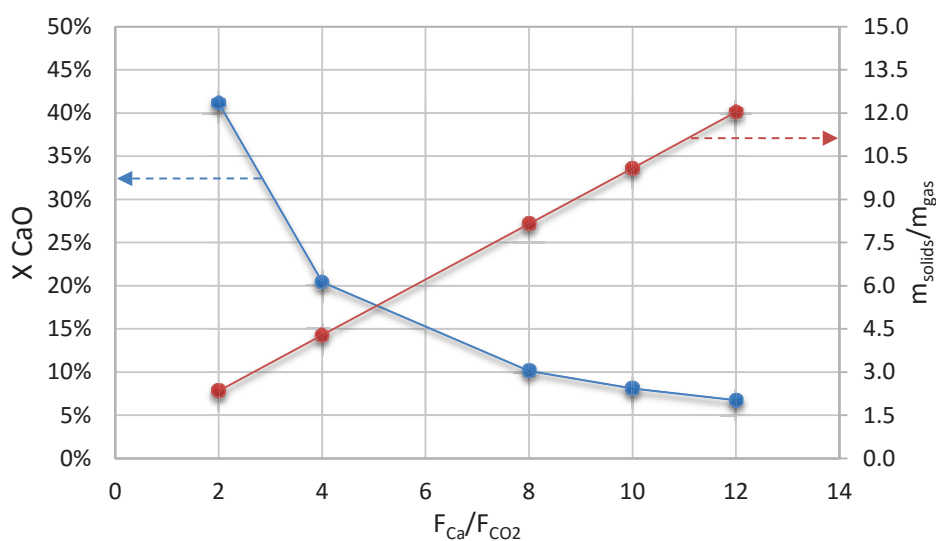

Fig. 4 CaO conversion and solids to gas mass ratio at carbonator outlet as a function of the F_{Ca}/F_{CO_2} ratio in this reactor for the assumed CO₂ capture efficiency of 80%)

3. Methodology

Mass and energy balances have been solved using GS code, developed at the Department of Energy at Politecnico di Milano [11]. This code assumes ideal behavior for pure solids, liquids and gases (including mixtures), whose thermodynamic properties are calculated by means of NASA polynomials [12], whereas pure water/steam is treated as real fluid, using IAPWS 97 thermodynamic properties.

A model for a state-of-the-art cement kiln without CO₂ capture has been developed to be used as a benchmark for the proposed configurations. This reference plant is based on the European BREF document for the manufacture of cement [13] and consists of a ~3000 t_{clik}/day cement plant with a dry kiln rotary process, a five stage cyclone preheater, a calciner with a tertiary duct and a grate cooler. The model has been calibrated with the model developed by VDZ, which was used in previous ECRA [14] and IEAGHG works [15].

In addition to basic performance indexes like specific primary energy consumption (q) and direct CO₂ emissions (e_{CO_2}), the following performance indicators have been considered in the analysis.

- *Equivalent primary energy consumption* (q_{eq}): this index represents the primary energy consumption associated to the total heat input into the plant and that associated to the net electric consumption in the process (P_{el}), calculated according to Eq.(2). For calculating the primary energy consumption related to P_{el} , a reference electric efficiency ($\eta_{ref,el}$) equal to 44.2% is assumed, which is in line with the efficiency of a state-of-the-art coal-fired power plant using the same fuel of the cement plant. When there is an electricity import into the process, P_{el} is positive and the equivalent primary energy consumption in the process is higher than the heat input into the plant (i.e. $q_{eq} > q$).

$$q_{eq} = q + \frac{P_{el}}{\eta_{ref,el}} \quad (2)$$

- *Indirect CO₂ emissions* ($e_{CO_2,el}$): emissions associated to the net electric consumption P_{el} , estimated according to the specific emissions of the reference electric production ($e_{ref,el}$), assumed equal to 785 kg/MWh (Eq.(3)). In case of electricity export to the grid, P_{el} is negative and indirect emissions are negative as well, indicating a credit of CO₂ emissions associated to the surplus of electricity exported to the grid.

$$e_{CO_2,el} = P_{el} \cdot e_{ref,el} \quad (3)$$

- *Equivalent CO₂ emissions* ($e_{CO_2,eq}$): total emissions calculated as the sum of direct and indirect emissions (Eq.(4)).

$$e_{CO_2,eq} = e_{CO_2} + e_{CO_2,el} \quad (4)$$

- *Specific Primary Energy Consumption for CO₂ Avoided* (SPECCA) is calculated according to Eq.(5) and represents the specific equivalent primary energy consumption needed in the cement plant with CO₂ capture per unit of CO₂ captured with respect to the benchmark cement plant without CO₂ capture.

$$SPECCA = \frac{q_{eq} - q_{eq,ref}}{e_{CO_2,eq,ref} - e_{CO_2,eq}} \quad (5)$$

4. Results discussion

Table 1 reports the overall results obtained for two selected cases of the two CaL configurations, compared with the reference cement kiln without CO₂ capture.

The tail-end CaL configuration is characterized by significant increase of the total fuel input (2.7 times the reference plant without capture), resulting in a large thermal power available for power generation. The heat recovery steam cycle (calculated assuming live steam parameters of 100 bar/ 530°C, two feed water preheaters and resulting in an electric efficiency of about 36%) in this case produces 68.3 MW_{el} (or 579 kWh/t_{clik}). This production exceeds the internal consumptions of the cement production process (consuming 97 kWh/t_{cement} or 132 kWh/t_{clik}), of the ASU (230 kWh/t_{O₂}), of the CO₂ compression unit (113 kWh/t_{CO₂}) and of the CaL fans (calculated assuming a pressure drop of 20 kPa in the carbonator and calciner) and leads to a net power export of 159 kWh/t_{clik}. This net electric power export brings about negative CO₂ indirect emissions, resulting in very low overall equivalent emissions (19.7 kg/t_{clik}) and avoided CO₂ emissions as high as 98%.

In the integrated CaL configuration, the fuel input is much lower than in the tail-end case, with an increase by 47% with respect to the reference plant without CO₂ capture. A lower gross electric power output is therefore produced by the heat recovery steam cycle (19.3 MW_{el}, or 163 kWh/t_{clik}), which however largely covers the additional electric consumptions associated to air separation, CO₂ compression and additional fans. As a result, this plant remains a net importer of electricity, with a specific consumption of 164 kWh/t_{clik}, which is almost equivalent to the power import of the reference cement plant. The resulting equivalent CO₂ emissions in this case are 200 kg/t_{clik}, 79% less than the reference case. The SPECCA index in the integrated CaL case is 2.32 MJ/kg_{CO2}, vs. 3.26 MJ/kg_{CO2} of the tail-end case.

Table 1 Performance of the tail-end CaL and integrated CaL configurations compared to the reference cement plant without CO₂ capture

	Reference cement plant without CO ₂ capture	tail-end CaL configuration with CFB reactors	integrated CaL configuration with EF reactors
Integration level [%]	--	20	100
F _θ /F _{CO2}	--	0.16	4.1
F _{C2} /F _{CO2}	--	4.8	4.0
Carbonator CO ₂ capture efficiency [%]	--	88.8	80.0
Total fuel consumption [MJ _{LHV} /t _{clik}]	3223	8672	4740
Rotary kiln burner fuel consumption [MJ _{LHV} /t _{clik}]	1224	1210	1180
Pre-calciner fuel consumption [MJ _{LHV} /t _{clik}]	1999	1542	3560
CaL calciner fuel consumption [MJ _{LHV} /t _{clik}]	--	5920	
Electric balance [kWh _{el} / t _{clik}]			
Gross electricity production	--	579	163
ASU consumption	--	-117	-73
CO ₂ compression	--	-146	-111
Carbonator and calciner fans	--	-25	-11
Cement plant auxiliaries	-132	-132	-132
Net electric production	-132	159	-164
Direct CO ₂ emissions [kg _{CO2} /t _{clik}]	863.1	143.2	71.4
Indirect CO ₂ emissions [kg _{CO2} /t _{clik}]	105.2	-123.5	128.7
Equivalent CO ₂ emissions [kg _{CO2} /t _{clik}]	968.3	19.7	200.1
Equivalent CO ₂ avoided [%]	--	98.0	79.3
SPECCA [MJ _{LHV} /kg _{CO2}]	--	3.26	2.32

5. Conclusions

Process integration of Calcium looping process in cement plants has been discussed, comparing two different integration levels and different reactors types. The first mass and energy balances of two selected cases have been also presented.

The first integration approach considered is the tail-end configuration, based on CFB CaL reactors. This configuration is a post-combustion, end-of-pipe option allowing high retrofitability of existing cement kilns. Being based on CFB reactors, which have been successfully demonstrated for the CaL process in different facilities up to 1.7 MW_{th} scale for application in power plants, minor technical uncertainties exist for this configuration. From the first mass and energy balances of a selected case, a significant increase of fuel input has been calculated with respect to the reference cement kiln without CO₂ capture (+270%), leading to specific primary energy for CO₂ avoided (SPECCA) of 3.26 MJ/kg_{CO2}.

The second approach considered is a highly integrated system, based on entrained flow CaL reactors tightly integrated in the cement kiln raw meal preheater. A solids population originated from the calcined raw meal (i.e. containing the other raw meal constituents in addition to the CaO) is used in this case as CO₂ sorbent. Some important research questions need to be answered in this case, associated to the reactivity of the calcined raw meal as CO₂ sorbent and to the fluid-dynamics of the entrained flow carbonator, which has to operate with higher solids to gas ratio than experienced in conventional preheating towers. The tighter thermal integration in this case allows reducing the fuel input significantly (+47% with respect to the reference cement kiln), leading to a SPECCA of 2.32 MJ/kg_{CO₂}.

Acknowledgements

This project has received funding from the European Union's Horizon 2020 research and innovation programme under grant agreement no 641185 (CEMCAP).

References

- [1] IEA. Cement Technology Roadmap: Carbon emissions reductions up to 2050. 2009.
- [2] CEMCAP EU H2020 Project n.d.
- [3] Arias B, Diego ME, Abanades JC, Lorenzo M, Diaz L, Martínez D, et al. Demonstration of steady state CO₂ capture in a 1.7MWth calcium looping pilot. *Int J Greenh Gas Control* 2013;18:237–45. doi:10.1016/j.ijggc.2013.07.014.
- [4] Kremer J, Galloy A, Ströhle J, Epple B. Continuous CO₂ Capture in a 1-MWth Carbonate Looping Pilot Plant 2013;36:1518–24. doi:10.1002/ceat.201300084.
- [5] Romano MC. Modeling the carbonator of a Ca-looping process for CO₂ capture from power plant flue gas. *Chem Eng Sci* 2012;69:257–69. doi:10.1016/j.ces.2011.10.041.
- [6] Kunii D, Levenspiel O. Circulating fluidized-bed reactors. *Chem Eng Sci* 1997;52:2471–82. doi:10.1016/S0009-2509(97)00066-3.
- [7] Grasa GS, Abanades JC, Alonso M, González B. Reactivity of highly cycled particles of CaO in a carbonation/calcination loop. *Chem Eng J* 2008;137:561–7. doi:10.1016/j.cej.2007.05.017.
- [8] Grasa GS, Abanades JC. CO₂ Capture Capacity of CaO in Long Series of Carbonation/Calcination Cycles. *Ind Eng Chem Res* 2006;45:8846–51.
- [9] Abanades JC. The maximum capture efficiency of CO₂ using a carbonation/calcination cycle of CaO/CaCO₃. *Chem Eng J* 2002;90:303–6.
- [10] Romano MC, Spinelli M, Campanari S, Consonni S, Marchi M, Pimpinelli N, et al. The Calcium looping process for low CO₂ emission cement plants. vol. 61, Elsevier Ltd; 2014, p. 500–3. doi:10.1016/j.egypro.2014.11.1158.
- [11] Gecos. GS software 2013.
- [12] Gardiner WC. *Combustion Chemistry*. Springer-Verlag, New York; 1984.
- [13] Schorcht F, Kourti I, Scalet B, Roudier S, Delgado Sancho L. JRC Reference Reports- Best Available Techniques (BAT) Reference Document for the Production of Cement, Lime and Magnesium Oxide. 2013. doi:10.2788/12850.
- [14] Hoenig V, Helmut H, Koring K, Lemke J. ECRA CCS Project – Report on Phase III 2012:107.
- [15] Kristina Koring, Volker Hoenig, Helmut Hoppe, Johannes Horsh, Christian Suchak, Verena Llevenz, Bernhard Emberger. Deployment of CCS in the Cement Industry. *leaghg* 2013:139.