

REVIEW



Cite this: DOI: 10.1039/d0re00411a

From circular synthesis to material manufacturing: advances, challenges, and future steps for using flow chemistry in novel application area

Alessandra Sivo,^{†a} Renan de Souza Galaverna,^{†b} Gustavo Rodrigues Gomes,^{†b} Julio Cezar Pastre ^{*b} and Gianvito Vilé ^{*a}

Continuous-flow technologies are becoming increasingly relevant in the chemistry field. The vast arrays of reactor design, in terms of structural geometry, mixing, and residence time, the modularity of these systems, adaptable for every application, and the easy downstream integrations are at the basis for their success. Over the past decade, the value and potential of flow technologies became apparent, particularly for drug discovery and drug development. However, other areas of research, which include the circular valorization of waste products and the manufacturing of materials and catalysts, have been less touched by the revolution that miniaturization brings in terms of efficiency, safety, environmental impact, and processability. This review critically evaluates the emerging use of flow technologies in these areas, highlighting recent advances, current challenges, and future directions in the quest for leaner and cleaner processing methods.

Received 24th October 2020,
Accepted 16th December 2020

DOI: 10.1039/d0re00411a

rsc.li/reaction-engineering

1. Introduction

Chemists and chemical engineers have seen over and over the emergence of technologies that promised to modernize materials and process development (e.g., parallel and combinatorial chemistry, microwave synthesis, computational methods). These technologies have often

failed in the transition from the research lab to the industrial world, as they did not provide significant improvements in the way we perform chemistry. On the other hand, over the past 15 years, chemists around the world have demonstrated remarkable potential in the use of continuous-flow reactors for chemical synthesis and in the transition from batch to flow processes in manufacturing.¹ Even though fine chemical processes are often carried out in batch pilot plants (particularly when the production volumes are small, as in the case of pharmaceuticals and agrochemicals), flow chemistry has forced the industries to rethink their processes and consider this technology as a real and meaningful alternative to standard practices. As a result, pharmaceutical

^a Department of Chemistry, Materials and Chemical Engineering “Giulio Natta”, Politecnico di Milano, Piazza Leonardo da Vinci 32, IT-20131 Milano, Italy. E-mail: gianvito.vile@polimi.it; Tel: +39 02 2399 3036

^b Institute of Chemistry, University of Campinas – UNICAMP, PO Box 6154, 13083-970, Campinas, SP, Brazil. E-mail: jpastre@unicamp.br; Tel: +55 19 3521 3143

[†] These authors contributed equally.



Alessandra Sivo

Alessandra Sivo graduated in pharmaceutical chemistry from the University of Bari ‘Aldo Moro’. In May 2020, she started her PhD studies at Politecnico di Milano under the supervision of Dr. Gianvito Vilé. Her research combines synthesis, catalysis, and microreactor technology to develop circular, continuous methods for pharmaceutical applications.



Renan S. Galaverna

Dr. Renan S. Galaverna was born in Brazil in 1989. He obtained his PhD in 2019 under the guidance of Prof. Julio C. Pastre at the University of Campinas – UNICAMP. This was followed by a brief one-year visiting fellowship at Cardiff University under the supervision of Prof. Duncan L. Browne. His current research interests include the development of flow methodologies for organic synthesis, biomass conversion, and medicinal chemistry.

companies have been the first to take steps towards the implementation of flow chemistry, also driven by the need to reduce their environmental impacts, increase process safety, and modernize their facilities.

Flow chemistry is the technique that enables carrying out standard reactions in continuous-flow mode (Fig. 1), using microreactors (such as a coil or a chip reactor).² These are small-volume flow cells that are optimized for the continuous and consistent production of a target compound. Their volumes and channels can range from microliter to mesoliter scale and are thus optimal for pharmaceutical and biomedical manufacturing. More specifically, in a flow reactor, the components are pumped together in a mixing junction and flow through a temperature-controlled unit where the reaction takes place.³ Compared to batch processing, continuous-flow systems offer several advantages such as more efficient mixing schemes, rapid heat and mass transfer, and increased safety.⁴ Moreover, a temperature range between $-80\text{ }^{\circ}\text{C}$ and $250\text{ }^{\circ}\text{C}$ and a pressure range of 1–

10 bar represent the conventional limits in traditional synthetic chemistry.⁵ In flow mode, significantly higher temperatures (up to $500\text{ }^{\circ}\text{C}$) and pressures (100 bar) are possible, and alternative heating methods (such as inductive, microwave, and flash heating) have been developed to attenuate the sensitivity of molecules at severe reaction conditions. This permits the use of solvents above their boiling points, at supercritical conditions. It also allows process intensification, which leads to lower operation, maintenance, and capital expenditures as well as increased modularity and minimized physical footprints.⁶

Flow chemistry represents one of the key enabling technologies that have brought sustainability into drug discovery and drug manufacturing. Within the past ten years, this technology has found applications in the whole pharmaceutical value chain, from compound libraries in drug discovery⁷ to chemical development and drug delivery.⁸ One of the most exciting ways in which flow chemistry has positively impacted drug discovery is through the exploitation of new and previously unexplored chemical space. This includes chemical reactions that were previously considered out-of-scope in organic synthesis laboratories due to safety concerns (e.g., carbonylation or halogenation).⁴ In addition, flow chemistry has simplified the scalability of scaffolds and building blocks and improved reaction yields, significantly supporting medicinal chemistry programs during initial hit-to-lead phases.⁹ At process scale, flow chemistry has enabled the rapid synthesis of active pharmaceutical ingredients (APIs) by the integration of multiple reaction and purification steps into one single cascade. The entire synthesis of drugs could be automatized, and multicomponent reactions could be performed by introducing reactants at any point in the flow path (Scheme 1).¹⁰

More recently, the possibility to synergistically combine reaction, purification (for example, through a series of immobilized scavengers and crystallization units), and



Gustavo R. Gomes

Gustavo R. Gomes graduated in chemistry from the Federal University of Paraná. He is currently a PhD student in the Pastre research group at the University of Campinas – UNICAMP. His research focuses on developing new catalytic systems based on deep eutectic solvents and ionic liquids obtained from renewable resources, and on their implementation on carbohydrate conversion using enabling technologies.



Julio C. Pastre

Julio C. Pastre obtained his PhD in 2009 under the guidance of Professor Carlos Correia at the University of Campinas – UNICAMP. He then worked as a research scientist at Rhodia before moving back to UNICAMP for postdoctoral studies with Professor Ronaldo A. Pilli. In 2012, he joined the group of Professor Steven V. Ley at the University of Cambridge. Two years later, Julio established his independent research group at UNICAMP and

recently became associate professor. In 2019, he was recognized by Reaction Chemistry & Engineering as an ‘Emerging Investigator’ and by RSC Medicinal Chemistry as a ‘New Talent from the Americas’.



Gianvito Vilé

Gianvito Vilé obtained his PhD in 2015 from ETH Zurich under the guidance of Prof. Javier Pérez-Ramírez. He then moved to the industry as a lab head at Idorsia Pharmaceuticals, where he applied enabling technologies to reactions encountered in drug discovery. In 2020, he accepted a faculty position in Chemical Plants at Politecnico di Milano, where he now heads the Innovation Lab for Sustainable Process Intensification. His

research focuses on developing flow processes for pharmaceutical synthesis and designing single-atom catalysts for the continuous recovery of chemical and pharmaceutical pollutants.

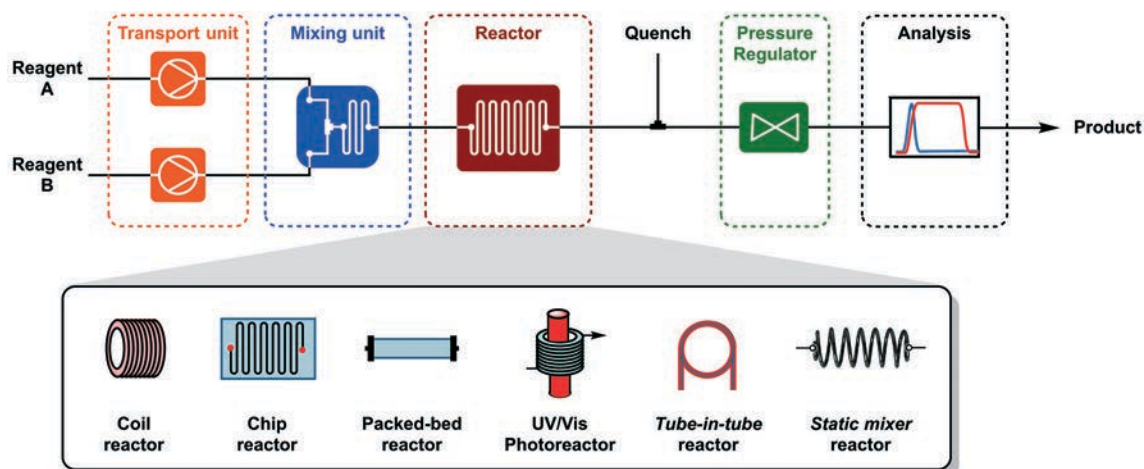
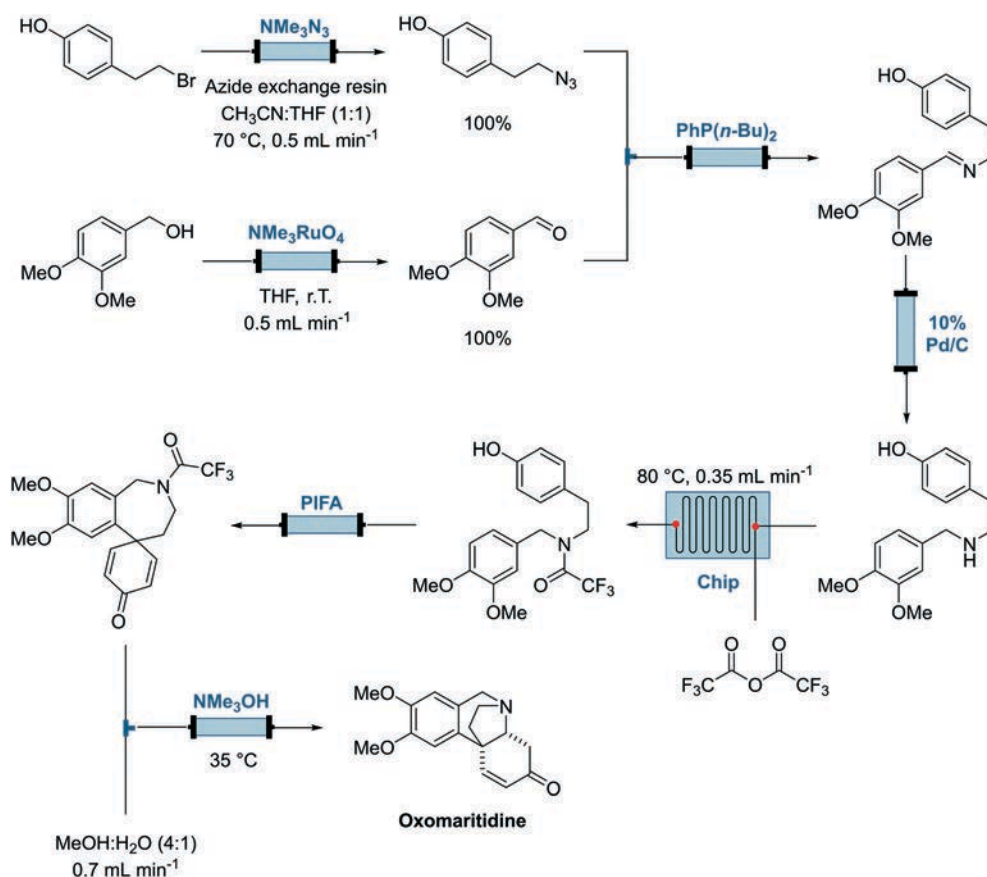

Fig. 1 General scheme of a flow chemistry setup.

formulation steps has assisted in the generation of integrated refrigerator-sized platforms capable of producing hundreds of individual doses of APIs within 24 h.¹¹ It has been proposed that such compact chemical miniplants will provide opportunities for the regional synthesis of pharmaceuticals and agrochemicals in developing economies based on the needs and demands of each country, opening unforeseen avenues for drastic changes in local commercial

manufacturing. Finally, due to the possibility to quickly implement in-line spectroscopic process analytical technology (PAT) tools to monitor continuous campaigns, it has been shown that chemical runs often exceed standard quality assurance specifications, providing a proof that the technology is eminently suitable for the efficient manufacturing of pharmaceutical products.¹² It is not surprising that in February 2019, the US Food and Drug



Scheme 1 Landmark multistep flow synthesis of oxomaritidine (adapted from ref. 10a).

Administration (FDA) has released a new Good Manufacturing Practice draft guideline,¹³ encouraging and fostering the use of flow chemistry to modernize and accelerate manufacturing lines, reducing material handling, allowing better process control, and building quality-by-design (QbD) into the complete product life cycle. Finally, for clinical phase I, II, and III, the excellent mixing and heat transfer of microreactors have allowed the production of kilogram-quantities of the material in a very straightforward manner. Based on the multiple advantages above, pharmaceutical giants have readily adopted this technology. GSK, for example, has invested over 95 million USD to build two continuous manufacturing facilities in Singapore. The hypoxia-inducible factor (HIF) prolyl-hydroxylase inhibitor daprodustat (GSK1278863) will be the first drug to be manufactured under a continuous-flow regime.¹⁴ The company has also an ambitious target of one third of its API portfolio being produced in flow regime within 2030.¹⁵ Eli Lilly was the first to synthesize kilograms of a cancer drug candidate (prexasertib) under continuous-flow conditions in 2017.¹⁶ Later on, in 2019, the company was awarded for their small-volume continuous facility located in Kinsale, Ireland.¹⁷ Companies such as Syngenta,¹⁸ Novartis,¹⁹ Sanofi,²⁰ AstraZeneca,²¹ and Johnson & Johnson²² are also incorporating continuous manufacturing strategies at various stages.

There are, however, sectors other than pharmaceutical, which can benefit from continuous manufacturing, and where the advantages of flow chemistry and microreaction engineering have not yet deeply infiltrated. Smart and functional materials such as biomedical nanoparticles, electronic nanostructures, and heterogeneous catalysts (even those used for pharmaceutical manufacturing) are often prepared in batch mode, using deposition-precipitation, impregnation, colloidal, or hydrothermal methods. This leads to broad particle size distributions, which affect the possibility to discriminate the intrinsic material behavior due to the lack of structural uniformity. The adoption of flow chemistry in the synthesis of nanoparticles and catalysts allows a novel process control window (Scheme 2).^{23,24}

Circular chemistry is another sector which could benefit from the progress made in the flow processing arena. For example, we envision the use of carbon dioxide and other 'waste' molecules as an alternative feedstock for chemical processes. From these 'waste' materials, useful products can be made under flow conditions, including plastics and

pharmaceutical building blocks. In this subfield, we can consider as well the efforts of those developing continuous-flow processes that make use of bio-based starting materials.^{25,26} For example, the Australian Licella Pty Ltd has devoted the equivalent of 75 million USD for the development of a circular continuous-flow platform (Cat-HTR™) to convert non-food biomass residues into biocrude oil.²⁷ The Norwegian Steeper Energy named their continuous hydrothermal liquefaction plant as Hydrofaction™ and a project worth 59 million USD was recently announced.^{28,29} A continuous pilot plant to convert municipal waste into oil with a productivity of 700 kg per day has been announced by the Italian oil-and-gas multinational ENI. The bio-oil can be obtained in a range of 3–16% depending on its constituents.³⁰ Further to the hydrothermal liquefaction process, commercial continuous pilot plants for pyrolysis can also be found.³¹ Most of these industrial studies are, however, still at the infancy stage.³²

Bearing this in mind, this review analyses the key achievements to date in adopting continuous-flow technologies in new, key research areas, including circular synthesis and material manufacturing, critically highlighting current challenges and future directions. We devote a significant emphasis to demonstrate the enhanced characteristics of products prepared under continuous-flow mode (compared to standard batch technologies). Moreover, we discuss the novel opportunities given by automation and 3D printing in translating traditional methods into flow mode.

2. Continuous synthesis for circular chemistry

A circular economy is a systemic approach to development designed to benefit society, companies, and the environment. In contrast to the linear 'take-make-waste' model, a circular economy aims at gradually decoupling growth from the consumption of finite resources. Circular chemistry goes hand in hand with circular economy, as it focuses on the sustainability and life cycle of chemical processes. Similar to green chemistry, twelve principles have been coined to define circular processes, and these are detailed in Table 1.³³ It is immediate that flow chemistry, as an enabling tool with unprecedented potential, can meet all of the goals of circularity.

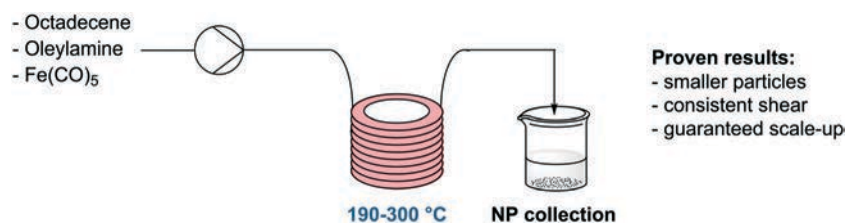

Scheme 2 Example of nanoparticle synthesis under continuous-flow conditions (adapted from ref. 24).

Table 1 The 12 principles of circular chemistry

Principle	Definition	Application to flow chemistry
i	Collect and use waste	Develop continuous processes that employ 'waste' materials as reagents
ii	Maximize atom circulation	Recover precious compounds (<i>i.e.</i> , C, N, Cl, I, Br, transition metals) from the 'waste' and recycle them
iii	Optimize resource efficiency	Maximize use of raw materials in flow-mode, reducing costs
iv	Strive for energy persistence	Develop continuous processes with low energy requests and use, if possible, renewable energy sources
v	Enhance process efficiency	Enhance reaction yield by developing optimal reactor geometries
vi	No out-of-plant toxicity	Ensure no generation of toxic compounds after reaction. Minimize by-product formation. Prepare and use <i>in situ</i> toxic compounds
vii	Target optimal design	Optimize flow processes
viii	Assess sustainability	Design continuous processes in which the reduction of pollutants, solvents, and energy consumption leads to environmental and economic benefits
ix	Apply ladder of circularity	Reuse reactor and reaction components which are still in good condition and fulfil their original functions, avoiding discharging
x	Sell services, not products	Support the process industry developing flow chemistry roundtable and services to expand the adoption of these technologies
xi	Reject lock-in models	Ensure machine integration and exploit systems capable of standardization
xii	Unify industry and provide coherent policy framework	Exploit potential of integrating several concepts together, for example preparing catalysts and polymers for synthesis and manufacturing also in continuous mode

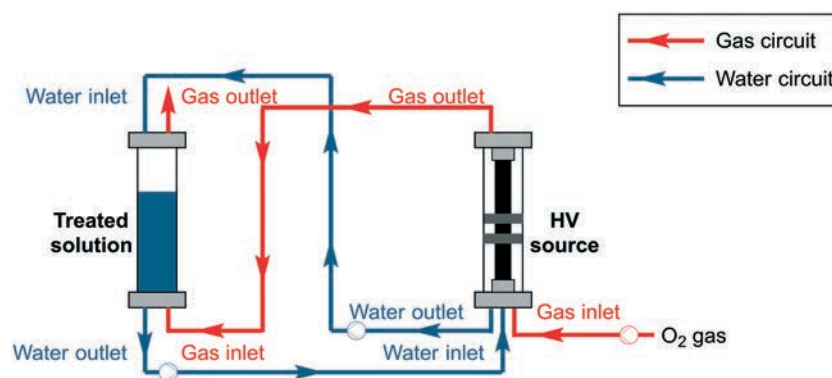
**Scheme 3** Schematic representation of the plasma-ozonation reactor system used to remove alachlor from gaseous streams (adapted from ref. 34).

For this reason, this section reviews recent literature examples where continuous processes have been employed to recover chemicals, convert 'waste' materials, and use 'bio-based' reactants.

Vanraes and co-workers recently reported a new process for the removal of alachlor in water by non-thermal plasma (Scheme 3), making a comparison between the removal efficiency and reactor performance for the recirculation method and single pass mode (referring to the ozonation process).³⁴

Oehlmann and co-workers studied the enzymatic degradation of hormones and endocrine disrupting compounds (EDCs) in wastewater using fungal-derived laccases.³⁵ In their study, immobilized laccase was stacked in a column and subjected to a continuous flow of wastewater (Scheme 4). The system was able to remove EDCs impurities with high leaching resistance and the activity and mechanical stability of the immobilized laccase was better compared to the 'free' enzyme.

The exploitation of CO₂ as a reactant is also important for circular flow applications. Carbon dioxide may be used as C1

feedstock for both organic synthesis and fuel engineering, resulting in several important products such as CO, CH₄, methanol, olefins, hydrocarbons, higher alcohols and others.³⁶ CO₂ hydrogenation is currently a major topic of research, with the aim of generating syngas (CO/H₂) for organic synthesis or C₂H₄ for polymer and fuel production.³⁷ Ren *et al.* reported a selective electrochemical method for CO₂ reduction to CO mediated by cobalt phthalocyanine in a flow electrolyzer, achieving >95% CO selectivity (Scheme 5).³⁸

Jeng and Jiao developed a single-pass CO₂ conversion in a flow electrolyzer, composed of silver nanoparticles as cathode and iridium oxide as anode. The authors attained a gas stream from the cathode containing approximately 80% CO, 15% H₂ and 5% unreacted CO₂; the product stream was then used as syngas for organic synthesis (Scheme 6).³⁹

Another example is the upgrade of epoxides to carbonates in the presence of CO₂. Bui *et al.* prepared a novel mesoporous melamine formaldehyde resin as heterogeneous catalyst for cyclic carbonate synthesis in flow regime. The authors obtained carbonates in yields that varied from 76%

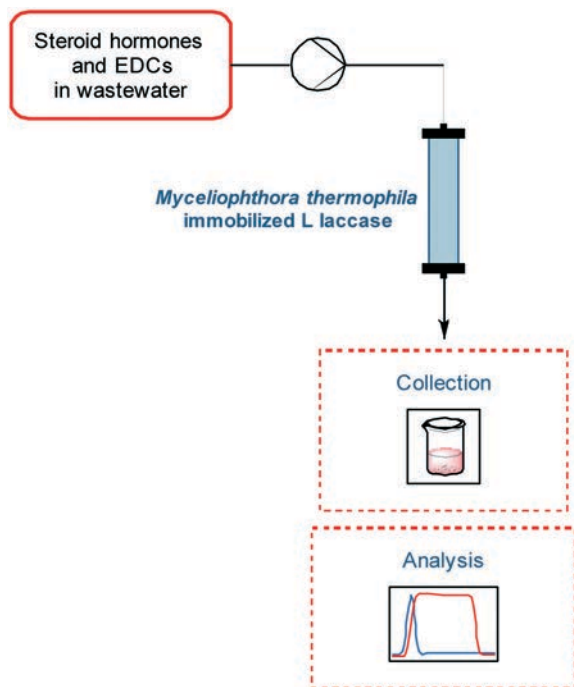

Scheme 4 Schematic representation of a continuous process used to remove pharmaceutical pollutants in water (adapted from ref. 35).

to 100% at 120 °C and 13 bar, under solvent-free and catalyst-free conditions. The flow method demonstrated as well excellent recyclability and stability for more than 13 days of continuous run (Scheme 7).⁴⁰

The above-mentioned examples highlight the practicality of taking advantage of waste chemicals and converting them into new marketable products. Along these lines, Browne and co-workers demonstrated the valorization of food waste by the metathesis reaction of cocoa butter triglyceride under a flow regime.⁴¹ The targeted compound, 1-decene, is a widely used intermediate in the manufacture of surfactants. A tube-in-tube gas-liquid flow reactor was employed to deliver ethylene for the ethenolysis reaction of triglycerides containing mainly the alkene oleic acid. Yields up to 41% for 1-decene were reported (Scheme 8).

One of the major drawbacks in carbohydrate chemistry is the formation of humins, an alternative ‘waste’ compound.

These species are commonly formed during the acid-catalyzed hydrolysis of C₅-C₆ sugars and result in a lower process efficiency. In a pioneering contribution, Luque and co-workers demonstrated that humins could be valorized in flow mode by extraction of its components, such as 5-methoxymethylfurfural (MMF).⁴² MMF was first obtained from humin by column chromatography and was subsequently hydrogenated to produce tetrahydrofuran derivatives in continuous mode using a packed-bed reactor containing 5% Ru/C and 5% Pd/C as catalysts (Scheme 9).

Biomass research fits nicely with several principles of circular chemistry. For example, biomass is an unlimited source of organic carbon due to its renewable character (principle iii). Carbon dioxide released by its combustion is balanced by the amount of CO₂ consumed during biomass growth (principles i and ii), meeting the United Nations Sustainability Goal of zero waste. Thus, biomass conversion can play a central role in the development of a circular flow platform. From a chemical perspective, lignocellulosic biomass is a polymeric material mostly composed of three primary units: (i) cellulose (a crystalline polymer made up of glucose units); (ii) hemicelluloses (amorphous polysaccharides composed of C₅ and C₆ units); and (iii) lignin (a three-dimensional polymer made up of coumaryl, coniferyl, and synapyl alcohols). From these compounds, a series of valuable chemicals can be obtained by physical, chemical, or biological transformations.⁴³ While biomass can be directly converted into a mixture of pyrolysis oil or syngas through high-temperature, unselective thermochemical processes, their components (*i.e.*, lignin, cellulose/hemicellulose, proteins, and salts) can be separated only *via* physical, chemical, and biological treatment. Physical delignification produces aromatic compounds from lignin, hydrolysis converts cellulose/hemicellulose into C₅-C₆ sugars, and protease enzymes degrade proteins into amino acids. Finally, the obtained aromatic rings, C₅-C₆ sugars, and amino acids can be chemically or biologically transformed into a diversity of chemicals (Scheme 10).⁴⁴

In this perspective, syngas was used by Kappe and co-workers for the synthesis of aryl aldehydes by formylation of C₆ sugars under a flow regime.⁴⁵ The process was run in a gas-liquid segmented flow regime and 17 examples were

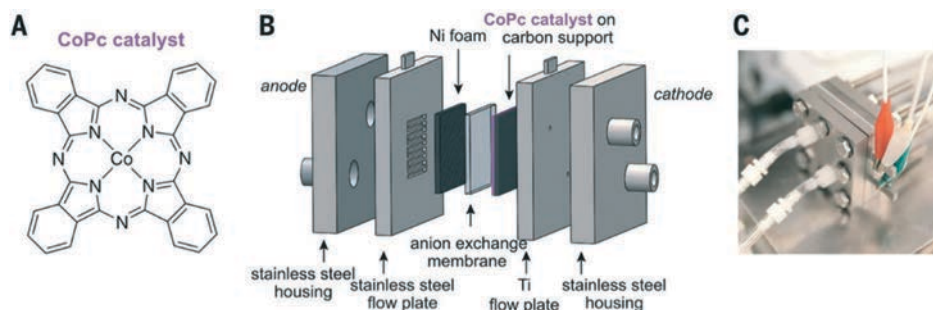

Scheme 5 Cobalt phthalocyanine catalyst (A), reactor nanostructure for CO₂ electroreduction (B), and assembled flow cell (C) (adapted from ref. 38).

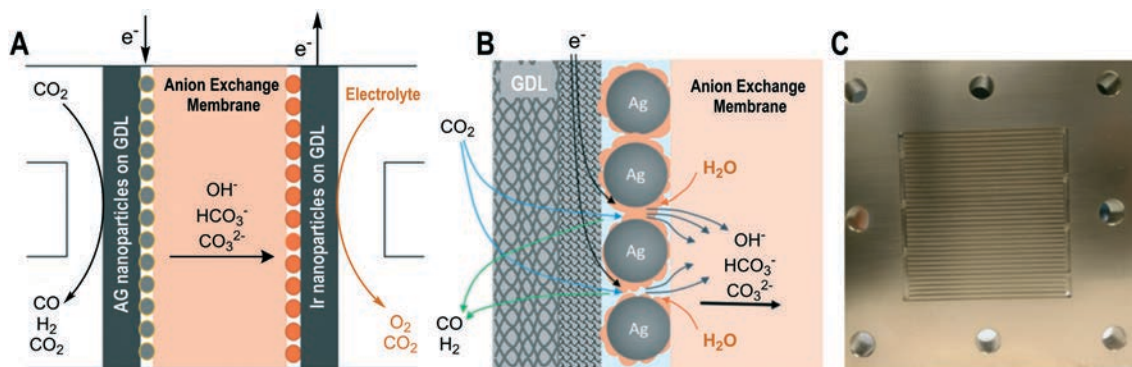

Scheme 6 Flow cell configuration for CO₂ conversion (A), chemical processes taking place at the surface (B), and flow reactor serpentine used for chemical synthesis (C) (adapted from ref. 39).

demonstrated using (hetero)aryl bromides as starting materials. The optimized condition required 1 mol% PdCl₂, CO/H₂ in a ratio of 1:3, a reaction temperature of 120 °C, and a residence time of 45 min (Scheme 11).

One of our groups recently demonstrated the synthesis of monomers from biomass derivatives under a flow regime.⁴⁶ Using terpenes as starting materials, a small library of saturated and unsaturated monomers was produced in excellent yields (up to 96% for two steps). The process was composed of two steps and started with a Diels–Alder reaction followed by catalytic hydrogenation using a tube-in-tube reactor in a recycling system. Scale up was also demonstrated and, using α -terpinene as starting material, 10.6 g of terpene were prepared over 3 h (3.53 g h⁻¹) in the first step and 10.15 g over 16 h (0.634 g h⁻¹) in the second step (Scheme 12).

Many other strategies have been developed in flow for the synthesis of fine chemicals from biomass or its derivatives.⁴⁷ For example, lactic acid can be converted into a series of compounds including 2,3-pentanedione, propanoic acid, lactamide, and acrylic acid. Glycerol can be transformed into glycolic acid, nitroglycerine, dihydroxyacetone, acetol, propene, and epichlorohydrin. Glucose into gluconic acid,

5-HMF, and sorbitol. Furfural into N-heterocycles. Several other bio-based starting materials can be precisely converted into valuable chemicals, as summarized in Table 2.

Several organic transformations can be mediated as well by biotechnological tools, such as biocatalysts. Biocatalysis is considered a green technology for organic synthesis due to its high activity and selectivity under mild conditions.^{87,88} For this reason, flow biocatalysis has been growing as a trend over the years and, probably, flow chemistry will help in the wider adoption of biocatalysis by the synthetic organic chemistry community. According to Scopus, 202 papers have been published in the area in the last two decades, started with only one paper in 2000, and reaching 31 publications per year in 2019 (Fig. 2).

The implementation of enzymes and/or whole cells in flow regimes relies on their immobilization, regardless of whether the method to do so is based on physical adsorption or chemical binding.⁸⁹ Weiser *et al.* reported an advanced sol-gel system for the immobilization of lipases, the most used enzyme in organic synthesis due to its ability to catalyze a wide range of reactions, such as esterification, transesterification, hydrolysis, aminolysis, and polymerization.⁹⁰ Remarkably, using just 1 g of native *Candida antarctica* lipase entrapped on a silica-based resin, 2.2 kg of product in the alcohol kinetic resolution with high enantiomeric purity (99.4% ee) and 3.3 kg of product in the amine kinetic resolution, also with high enantiomeric purity (99.8% ee), were successfully obtained. Similarly, Britton and co-workers reported a vortex fluid device to drive formation of thin films that can be applied in multi-step transformations, such as biocatalysis and protein purification, in a single reactor (Fig. 3).⁹¹ The authors used a fused histidine tag for purification through complexation with an immobilized metal affinity chromatography bed (Fig. 3). Firstly, the reactor was eluted with Ni²⁺ to charge the resin. Next, the protein solution entered the flow system for purification. After that, residual Ni²⁺ was washed out with a phosphate-buffered saline solution. The reactor was eluted with imidazole for protein recovery or used directly for the biocatalytic transformation (Fig. 3). To demonstrate the ability of multi-step biocatalysis, the authors reported a two-step production of

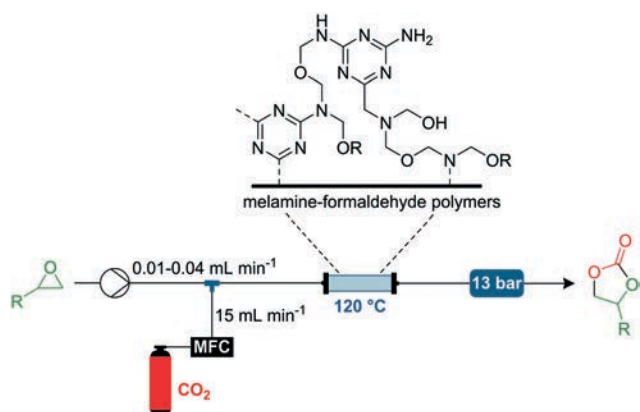

Scheme 7 Schematic diagram of the lab-scale fixed-bed process for cyclic carbonate synthesis (adapted from ref. 40).

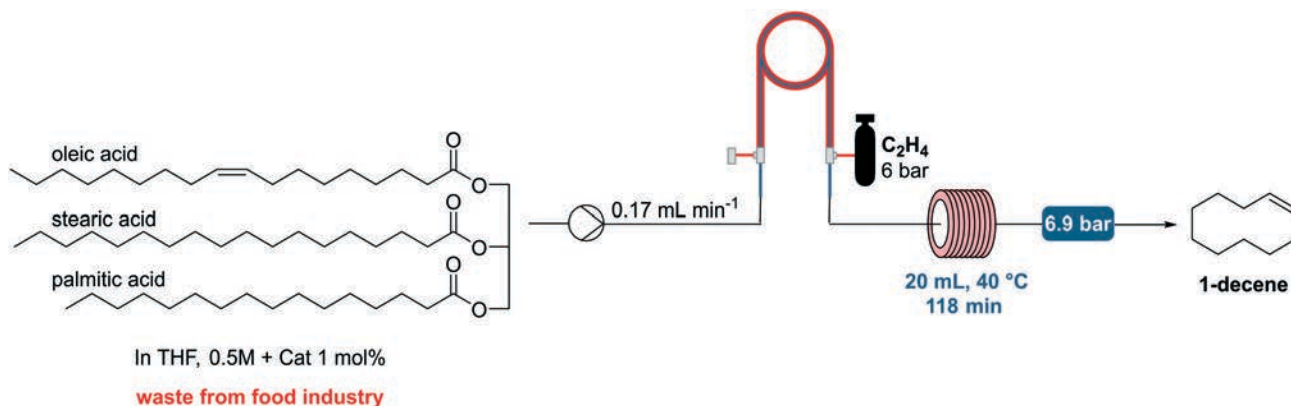

Scheme 8 Direct valorization of cocoa butter waste in a flow regime (adapted from ref. 41).

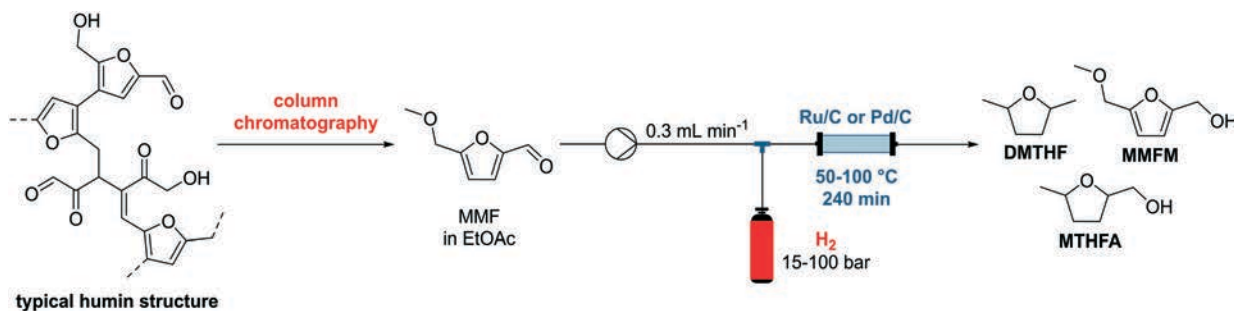

Scheme 9 Humin-derived MMF valorization in a flow regime (adapted from ref. 42).

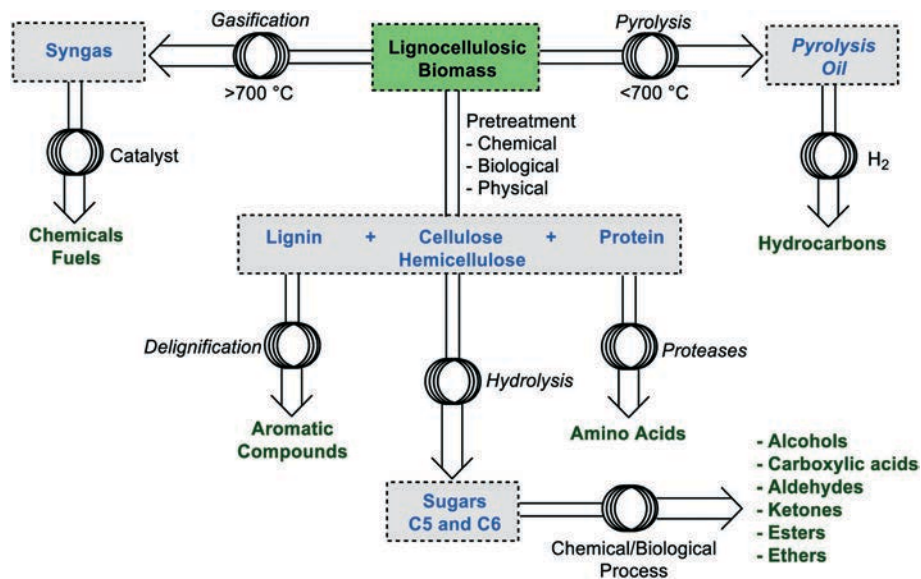

Scheme 10 Biomass uses in chemical manufacturing (adapted from ref. 44).

p-nitrophenoxide from bis(*p*-nitrophenol)phosphate mediated by phosphodiesterase and alkaline phosphatase. The reactor division into stripes, as shown in Fig. 3, allows rapid substrate transformation with less product inhibition due to the proximity of the different sections.

Cofactors play an important role in enzymatic bioreactions; however, the recycle of cofactors is often a drawback, making bioredox reactions difficult for industrial operation. Velasco-Lozano *et al.* developed a methodology for cofactor and enzyme immobilization for a self-sufficient

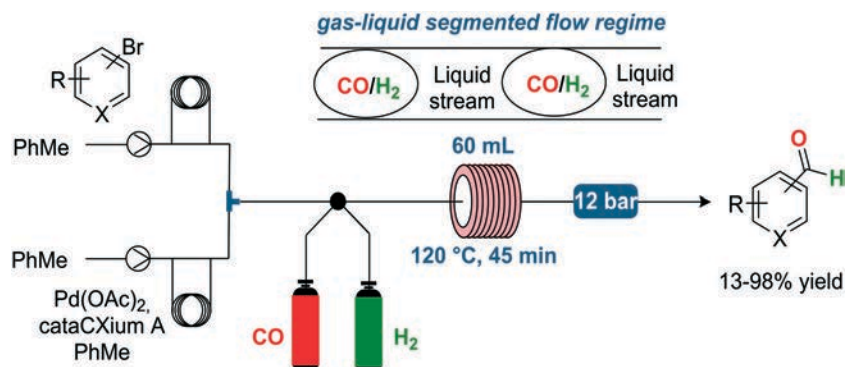

Scheme 11 (Hetero)aryl aldehydes synthesis using syngas under a flow regime (adapted from ref. 45).

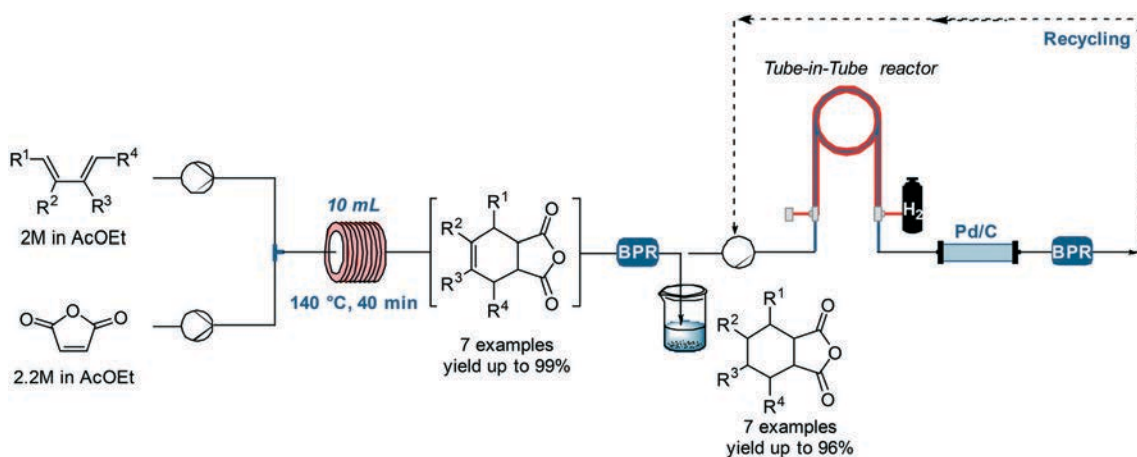

Scheme 12 Continuous-flow synthesis of platform monomers using terpenes (adapted from ref. 46).

heterogeneous biocatalysis.⁹² The schematic representation of immobilization technology is presented in Fig. 4. The main enzyme was immobilized on agarose microbeads activated with aldehydes followed by polyethyleneimine (PEI) coating (step 1). The recycled enzyme was co-immobilized by ionic adsorption on PEI and cross-linked with 1,4-butanediol diglycidyl ether for irreversible attachment (step 2); the cofactor was then adsorbed to the cationic bed (step 3). Under an optimal asymmetric reduction flow rate (50 $\mu\text{L min}^{-1}$), the reactor worked for 92 h with a ketone conversion higher than 90% and the corresponding alcohol was obtained with high enantiomeric excess (>99% ee) without lexiviation of the cofactors.

The examples prove that by carrying out enzymatic reaction on a fixed-bed system, several advantages are possible, including avoidance of toxic and rare/abundant transition metal catalysts and easier separation of the reagents/products from the biocatalyst. However, there are also some unsolved challenges. For example, the enzyme often loses considerable activity after immobilization. Complications with enzyme leaching and denaturation in organic solvents also pose some limitations in some transformations. Another challenge is their specificity, making them unsuitable for broad substrate scope screenings. Despite these challenges, flow biocatalytic

methods will continue to play an important role in increasing process efficiency and reducing carbon dioxide emissions into the environment, and we expect that these tools will be complementary to more traditional synthetic methods to recover materials from water and valorize CO₂ and waste chemicals in order to obtain value-added compounds for a fully circular economy.

3. Continuous synthesis of polymeric materials

The application of continuous-flow technologies in polymerization reactions has had a significant growth in recent years. According to Scopus, 902 papers on continuous polymerizations were published between 2000 and 2020, with a linear increase over the years (Fig. 5). Most of these studies deal with continuous stirred-tank reactors, which are examples of mechanically mixed flow reactors. Very few studies, however, have reported microflow technologies in polymer synthesis. This section wants to highlight some of the most representative contributions in this direction.

Flow chemistry can be applied to a variety of polymerization methods, including reversible addition-fragmentation chain-transfer (RAFT) polymerization,⁹³ atom-

Table 2 Synthesis of bio-based compounds under continuous-flow conditions

Biomass source	Target synthesis under flow	Ref.
Fructose, glucose, furfural, cellulose	5-Hydroxymethylfurfural (5-HMF)	48
Xylose	Furfural	49
Glycerol, glucose, lactose	Lactic acid	50
Levulinic acid	γ -Valerolactone	51
Isoeugenol	Vanillin	52
Fumaric and itaconic acid	γ -Butyrolactone	53
5-HMF	2,5-Furandicarboxylic acid	54
Vanillin	2-Methoxy-4-methylphenol	51d
Glucose	Gluconic acid	55
Lactic acid	Pyruvic acid	56
Kraft lignin	Vanillin	57
Glycerol	Glycolic acid	58
Glucose, xylose	Sorbitol, xylitol	59
Arabinose	Arabitol	60
4-Propylguaiacol	4-Propylphenol	61
Alkanes		
Methyl isobutyl ketone, HMF, fatty acids, sorbitol, xylitol, glucose	Methane, ethane, propane, butane, pentane, hexane, hexadecane, heptadecane, dodecane, C9-alkane, C15-alkane	62
Furfural	Tetrahydrofurfuryl alcohol	63
1,4-Butanediol	THF	64
Furfural, levulinic acid	2-Methyltetrahydrofuran	65
Furfural, 5-HMF, glycerol, lignin	Benzene, toluene, xylene, ethylbenzene	66
Glycerol, lactic acid	Acrylonitrile, acrylic acid, acrolein	67
Furfural, 1-butanol	Maleic anhydride	68
Diols		
Glycerol, levulinic acid, 5-HMF, sorbitol, succinic acid	1,2-PDO, 1,3-propanediol, 1,4-pentanediol, 1,4-BDO, 1,6-hexanediol, isosorbide	69
Lactic acid, methyl lactate	L-Lactide	70
N-Heterocycles		
Glycerol, furfural	Pyridines, quinoline, indoles, pyrazine	71
Glycerol	Solketal	72
Terpenes, maleic anhydride	Monomers	46, 73
Furfural, 5-HMF	2,5-Dimethylfuran, 2-methylfuran, furan	74
Carbonates		
Glycerol, EG, 1,2-PDO	Ethylene carbonate, glycerol carbonate, propylene carbonate	75
1,2-PDO	Methylglyoxal	76
Glycerol	Nitroglycerine	77
Glycerol	Dihydroxyacetone	78
Glycerol	Acetol	79
Glycerol	Propene	80
Glycerol	Epichlorohydrin and glycidol	81
Furfural	Furfuryl alcohol	82
Lactic acid	2,3-pentanediol	83
Lactic acid	Propanoic acid	84
Lactic acid	Lactamide	85
Levulinic acid	Ethyl levulinate	86

transfer radical polymerization (ATRP),⁹⁴ ring-opening polymerization,⁹⁵ and living anionic polymerization⁹⁶ among others. Due to the faster mass and heat transfer, the continuous-flow regime brings controlled molecular weight distribution, well-defined morphology, and more

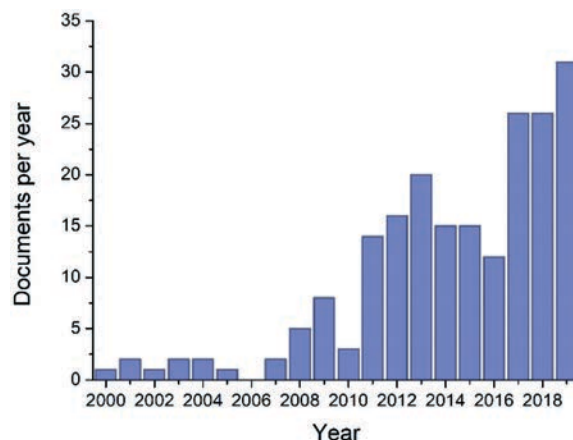
**Fig. 2** Number of publications on continuous-flow biocatalysis. Source: Scopus.

straightforward scale-up, overcoming the major technical challenges of traditional batch chemistry.⁹⁷ In this context, Lin and *et al.* developed a platform for the rapid and scalable synthesis of polyester and polycarbonate libraries, mediated by urea anion catalysis (Scheme 13).⁹⁸ In particular, 41 examples of polyester and polycarbonate homopolymers were prepared at room temperature and using extremely low residence times (*i.e.*, milliseconds to seconds). The resulting molecular weight distribution varied between 5400 and 25000 g mol⁻¹, with a polydispersity of around 1 (which indicates an extremely uniform distribution), pointing to a very efficient and homogeneous chain growth. Besides, a scale-up experiment for poly(L-lactic acid) preparation provided 16.5 g in only 40 s of residence time.

The authors also demonstrated the preparation of 100 examples of block polymers in noticeably short reaction times. The system was designed to enable catalyst switch for each block (Scheme 7). The polymerization started with the most basic urea anion interacting with the least reactive monomer in order to build the first block. The second block was built from the most reactive monomer in the first step using urea catalyst. The final molecular weight distribution varied between 7100 and 29000 g mol⁻¹ with a very narrow dispersity (around 1).

Junkers and co-workers developed instead an autonomous self-optimizing flow system with an online gel permeation chromatography for reversible addition-fragmentation chain-transfer (RAFT) polymerization of acrylates. The system gave an incredibly precise molecular-weight control that would have been impossible employing traditional batch methods (Scheme 14).⁹⁹ For example, the authors described a thermal RAFT polymerization of *n*-butyl acrylate, selecting the following molecular weights as target: 5000, 7500, and 10000 g mol⁻¹. At optimized reaction conditions, polymers with number-average molecular weights of 4996 ($\pm 0.1\%$), 7486 ($\pm 0.2\%$), and 10050 ($\pm 0.5\%$) g mol⁻¹ were produced.

Some flow regime parameters, and in particular residence time distribution, may also affect the polydispersity of the

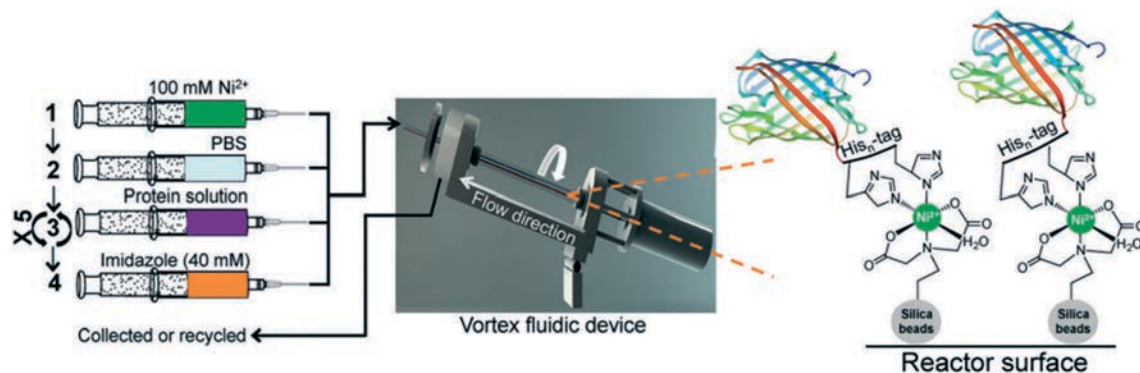

Fig. 3 Representation of continuous-flow purification, immobilization and biocatalysis in a single reactor developed by Britton and co-workers (adapted from ref. 91).

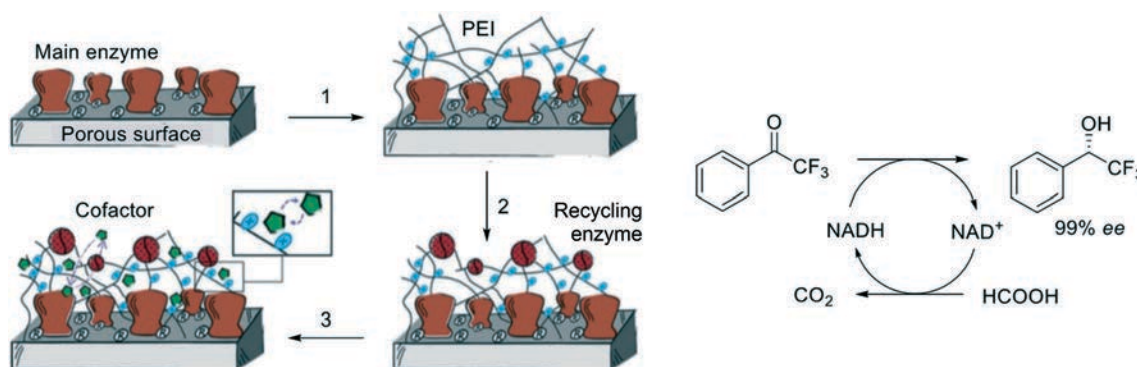

Fig. 4 Schematic representation of the immobilization technology reported by Velasco-Lozano *et al.* (adapted from ref. 92). This heterogeneous biocatalyst was then used for converting ketones into alcohols.

final materials. Reis *et al.* studied the influence of residence time distribution on polymer structure and composition.¹⁰⁰ Most polymerization reactions are conducted, in fact, in a laminar-flow regime. Due to the laminar flow, the velocity of the fluid varies between the center of the reactor (where it is

faster) and the reactor walls (where it is slower due to attrition), resulting in a broad residence time distribution which gives increased polydispersity (Fig. 6).¹⁰¹ To overcome this issue, Reis *et al.* chose a droplet-flow regime to carry out the polymerization reaction. In the synthesis of poly(valerolactone), the droplets provided a significant reduction in dispersity (from 1.33 under a laminar-flow regime to 1.07 under droplet-flow conditions). The authors also ran a scale-up experiment that enabled the production of 1.4 kg per day of well-defined polymers. These examples demonstrate that microflow setups with different mixing and reactor geometries can be used for the preparation of a variety of macromolecular architectures, independently of the polymerization technique used.

Continuous-flow polymerizations will continue to significantly contribute to developing new functional and smart materials with high precision, and we expect an increasing number of polymer synthesis protocols attained *via* microflow technologies. Besides the continuous synthesis of linear polymers, we expect some progress in the next years for the rapid preparation of nonlinear architectures. This includes dendrimers and (hyper)branched polymers. In addition to that, microreaction engineering offers intriguing features that have not been fully exploited to date in

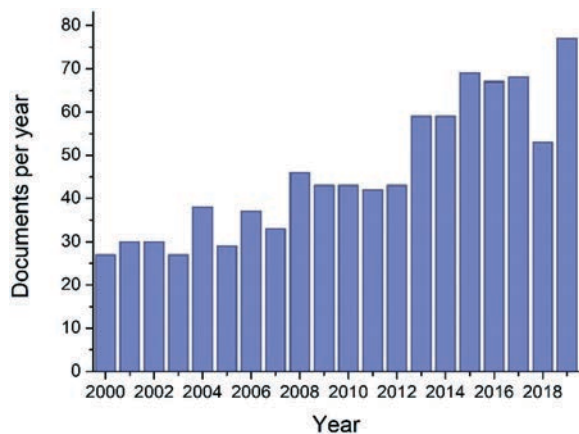
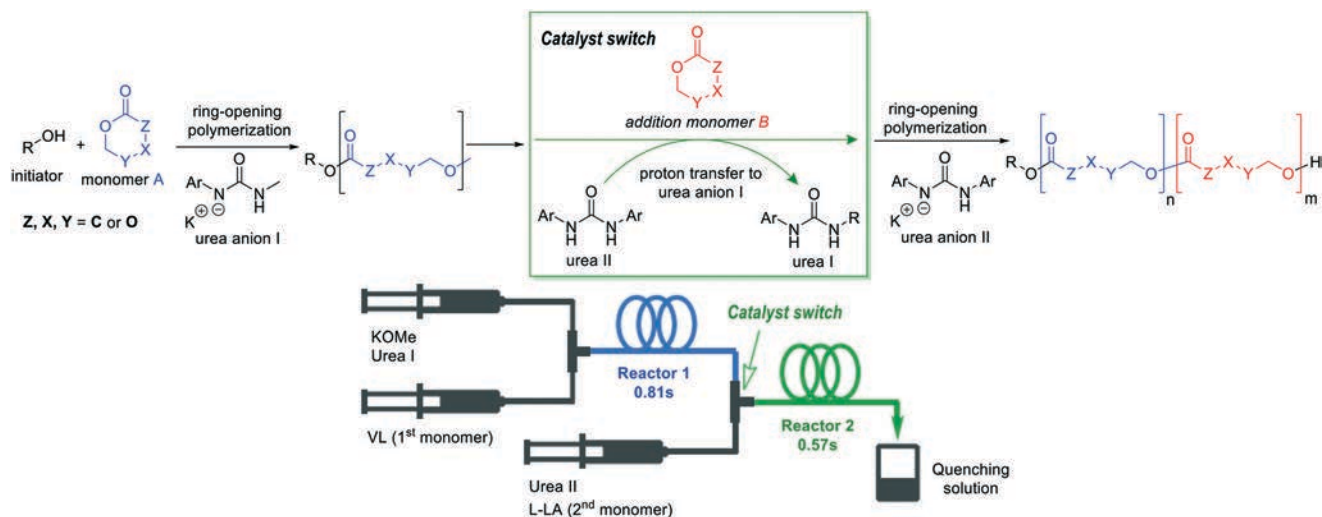
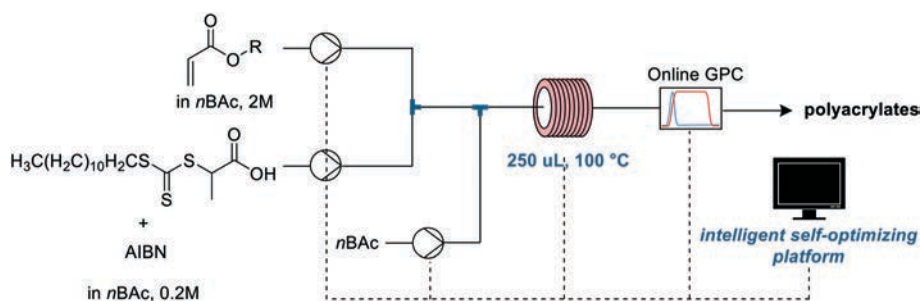

Fig. 5 Number of publications on continuous-flow polymerizations. Source: Scopus.



Scheme 13 Rapid and scalable synthesis of polyesters and polycarbonates (adapted from ref. 98).



Scheme 14 Autonomous flow system for acrylate RAFT polymerization (adapted from ref. 99).

polymerization chemistry. For example, flow units may permit polymerization of metastable monomers, such as vinyl alcohol, preventing tautomerism and rearrangement reactions, as in the case of organolithium chemistry. Such developments would go beyond the limits of batch systems. There are also polymerization methodologies poorly explored in flow regimes, such as photopolymerizations. To date, the latter methods have been mainly carried out using batch chemistry. Several groups are developing strategies to couple continuous-flow chemistry and photochemistry, producing polymers that exploit controlled radical mechanisms. However, a general flow method for photopolymerization is not yet available. Due to the advantages of continuous processes, polymerization methodologies could be designed in principle directly in flow. This direct approach would provide faster optimizations, increased process yields, and better control of the polymeric characteristics. Besides, an autonomous flow process may be the future for polymer synthesis and would provide precision in targeting specific physical-chemical properties (*i.e.*, molecular weight distribution, dispersity, and other properties) and constructing polymer libraries quickly and safely. The use of such an autonomous system will be discussed in the following sections.

4. Continuous synthesis of nanocatalysis

Traditionally, the synthesis of catalytic nanoparticles (NPs) is mediated in batch reactors, using traditional methods such as precipitation/co-precipitation, impregnation, hydrothermal synthesis, grinding, or gelation.¹⁰² However, the use of a batch-type vessel leads to batch-to-batch variations of the characteristics of the nanomaterials and presents difficulties for catalyst scaling up.¹⁰³ These issues can be solved by continuous-flow technologies, which provide mass and heat transfer efficiency and better control of the reaction time.¹⁰⁴ According to Scopus, 2124 papers about nanocatalysts synthesis in flow were published in the last twenty years. The numbers increased steadily from only 6 papers in 2000 to 254 papers in 2019 (Fig. 7).

One of the most interesting contributions came in 2016, when Kovalenko and de Mello reported the synthesis of cesium lead halide perovskite nanocrystals in a droplet-based microfluidic platform for solar applications.¹⁰⁵ Prior to that work, fully inorganic nanocrystals of cesium lead halide perovskite (CsPbX_3 , $\text{X} = \text{Br}, \text{I}, \text{Cl}$ and Cl/Br and Br/I) were prepared using conventional batch (flask-based) reactions. Unfortunately, the understanding of the parameters governing the formation of these nanocrystals was very

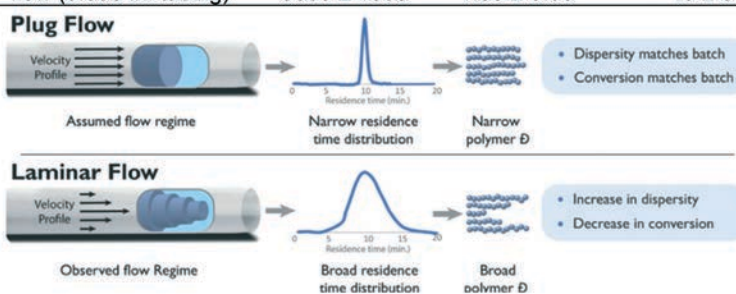
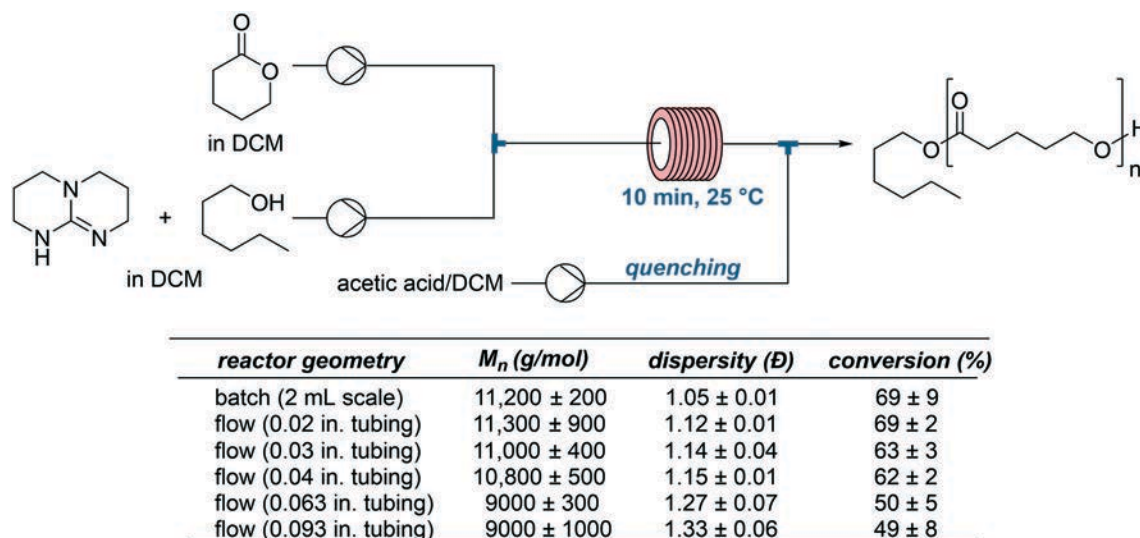

Fig. 6 Importance of flow regime during synthesis of poly(valerolactone) (adapted from ref. 101).

limited due to extremely fast reaction kinetics and multiple variables involved in ion-metathesis-based synthesis of such halide systems. The authors reported the use of a droplet-based microfluidic platform for the synthesis of CsPbX₃ nanocrystals. The combination of on-line photoluminescence and absorption measurements and the fast mixing of reagents within such a platform allow the rigorous and rapid mapping of the reaction parameters, including molar ratios of Cs, Pb, and halide precursors, reaction temperatures, and reaction times. This translated into enormous savings in

reagent usage and screening times when compared to analogous batch synthetic approaches.

One year later, Zhenlei *et al.*¹⁰⁶ reported the microfluidic synthesis of FePtSn/C catalysts with enhanced electrocatalytic performance for methanol fuel cells. The microstructures and compositions were characterized in-line using an impressive battery of benchtop techniques including transmission electron microscopy, high-resolution transmission electron microscope, energy-dispersive X-ray spectrometry, X-ray powder diffraction and X-ray photoelectric spectroscopy. The work extended that of Tsukuda and co-workers¹⁰⁷ on the microfluidic synthesis and catalytic application of PVP-stabilized Au clusters. Here, small PVP-stabilized gold clusters were successfully prepared by the homogeneous mixing of AuCl₄⁻ and BH₄⁻ in a micromixer. Benchtop in-line spectroscopic characterization revealed that microfluidic synthesis could yield monodisperse Au:PVP clusters with an average diameter of 1 nm, which is smaller than clusters produced by conventional batch methods.

Baddour *et al.* reported a methodology for molybdenum carbide NPs in flow for thermocatalytic CO₂ hydrogenation.¹⁰⁸ In this work, the authors selected molybdenum hexacarbonyl (Mo(CO)₆) as a precursor due to its low cost. However, the precursor is insoluble until around 100 °C and readily sublimes, which leads to moderate yields in batch (40–50% carbide NPs). These characteristics may limit the use of Mo carbides for industrial applications. To

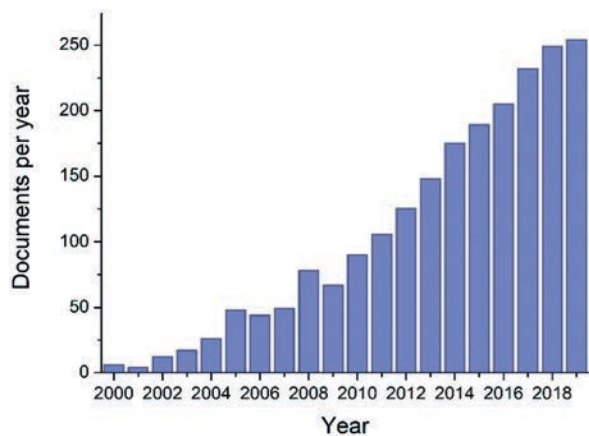

Fig. 7 Number of publications on continuous-flow synthesis of nanocatalysts. Source: Scopus.

overcome this limitation, the flow system used by the authors (Scheme 15) had a check valve to prevent backflow caused by gas evolution from $\text{Mo}(\text{CO})_6$ decomposition. The continuous-flow approach provided a significant improvement over batch reactions, with 8-fold higher $\text{Mo}(\text{CO})_6$ initial concentrations (625 vs. 78 mM), reduced reaction times (20 min vs. 1 h), and greater yields (99% vs. 40–50%). The system could be scaled up, leading to a productivity of 18.6 g h^{-1} of carbide NP.

Reaction parameters, such as temperature and residence time, can also affect an important property of the nanoparticles: its size. Loizou proved that the increase in temperature also grows the diameter of iron carbide core-shell NPs in flow, from 9.3 nm at 200 °C to 18.1 nm at 250 °C.¹⁰⁹ In addition, the authors reported that the size of iron carbides obtained in flow regime is bigger compared to batch. The synthesis of metal carbides depends on the decomposition of the carbonyl precursor. The authors hypothesized that pressure applied in the system caused a suppression on precursor thermal decomposition in the flow regime, which leads to more aggregations resulting in larger particles. Catalysis is by far the most important application of nanoparticle synthesis. However, the use of NPs has a huge impact on medical and pharmaceutical applications as well. Kim *et al.* reported a droplet-based flow microreactor methodology for the preparation of itraconazole (antifungal) nanoparticles.¹¹⁰ The nanosized drug is a strategy to improve its solubility, also an example of better control in synthesis associated with flow technology. The authors investigated two types of microreactors, metal cross junction for droplet systems and T-junction (Fig. 8).

One of the main advantages of flow chemistry in catalyst processing is the improved quality attributes of the nanomaterials prepared. Although this aspect will be better elaborated below, we can briefly say that the NP size distribution is narrower in droplet microreactors compared to batch systems, regardless of the flow rate. In droplets, the flow maintains the anti-solvent flow rate constant (dispersed phase), while the carrier fluid (continuous phase) provides more turbulence in the system that avoids agglomeration, and thus smaller particles are formed. Also, longer reactor

tubes contribute to agglomeration. Finally, the initial reactant concentration also plays an important role in achieving small particle size. The higher initial concentration could provide higher supersaturation to obtain smaller particles. However, the supersaturation correlates with the nucleation rate and growth rate exponentially and linearly, respectively. To improve solubility and achieve smaller nanoparticles, it is hence better to use a diluted reactant solution.

Overall, compared to batch systems, flow tools provide better control in both size and morphology during NP synthesis. Droplet-based microfluidic systems are the preferred solution for nanocatalyst synthesis because they can provide well-defined particles and narrower size distributions compared to tubular and batch reactors. Reactors that promote a turbulent flow are, in fact, desired. With the advent of 3D printing, it is possible to engineer reactors with unprecedented geometries and novel surface characteristics, further improving the fluid dynamics and consequently achieving an even better particle size and morphology control.¹¹¹ We predict that the role of reactor modelling and reactor design for nanomaterial synthesis will thus become key in the years to come.

5. Lessons learned through a decade of flow chemistry research

Now that we enter into a new decade of research needs, new (old) technical challenges might come back: how to we translate batch methods into flow mode to meet the standards of circular chemistry? How do we perform nanomaterial manufacturing avoiding channel blockage? Is there a general method to select optimal reactor and pumping systems? To address these questions, it is important to review what a decade of flow chemistry research has taught us. Hence, this section summarizes the key lessons and main technological solutions to the different problems encountered over the years.

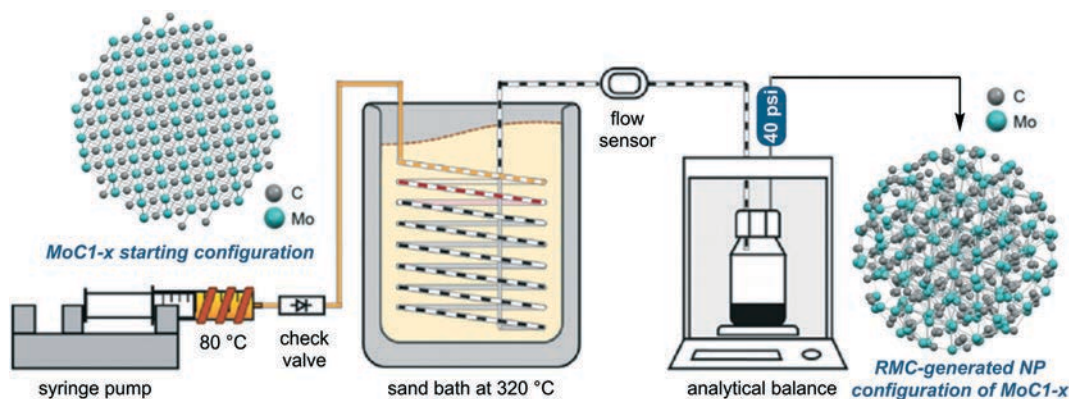

Scheme 15 Flow setup developed by Baddour *et al.* for molybdenum carbide NP synthesis (adapted from ref. 108).

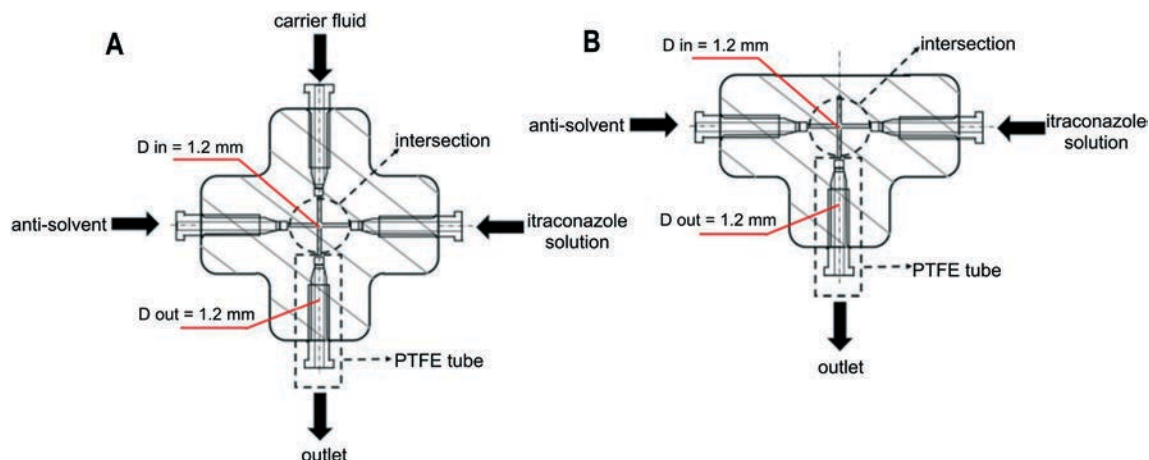

Fig. 8 Microreactor system used by Kim *et al.* for the synthesis of antifungal nanoparticles, showing in particular metal cross junction (A) and T-junction (B) configurations (adapted from ref. 110).

The importance of kinetics

Understanding the kinetics of a reaction (this being the circular synthesis of chemicals, a polymerization step, or the manufacture of NPs) is critical for the determination of the reaction mechanism and for the subsequent optimization process. Based on kinetics, reactions that would benefit from continuous conditions can be classified into three categories: flash reactions (where the kinetics is in the order of a few fractions of seconds), fast reactions (where the kinetics requires between 1 and 15 min), and slow reactions (taking longer than 15 min but suffering from dangerous conditions).

Within the first group (flash reactions), we have learned that we can carry out ultrafast methods with reaction time of less than one minute due to the possibility of controlling in a very precise manner the reaction time. Such reactions are typically difficult (or even impossible) to conduct in batch mode. For example, Vilé and co-workers¹¹² reported a continuous-flow synthesis of 2-methylproline and derivative using a substituted

D-alaninate as a starting material and LiHMDS as a base (Scheme 16). Both reagents were pumped at a flow rate of 1 mL min^{-1} into a cryogenic unit kept at -10°C , with a total residence time of 30 s.

Luisi and Nagaki provided another proof of flash technology and, by control of the residence time in a microflow reactor, they generated reactive intermediates and quickly used them before their natural decomposition (Scheme 17).¹¹³ Fluoriodomethane, in this case, reacted with MeLi in the first mixer, generating fluoromethyl lithium, whose lifetime is typically within the order of a few milliseconds. This highly unstable intermediate reacted with an electrophile in a setup featuring a total residence time of 13 milliseconds and very low temperature (-60°C).

Finally, Takeda Pharmaceuticals developed a process for the synthesis of TAK-117, a selective PI3K α isoform inhibitor.¹¹⁴ In this case, both the lithiation and the borylation are ultra-fast steps and were conducted in microreactors with a yield of more than 85% (Scheme 18).

Within the second group, we have rapid reactions whose residence time is between 1 and 15 min. Here, flow chemistry

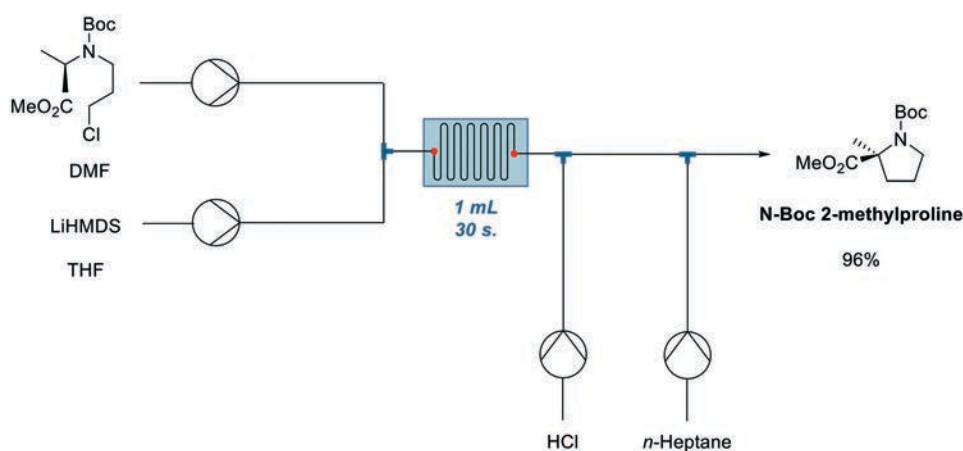

Scheme 16 Continuous-flow synthesis of 2-methylproline and derivative (adapted from ref. 112).

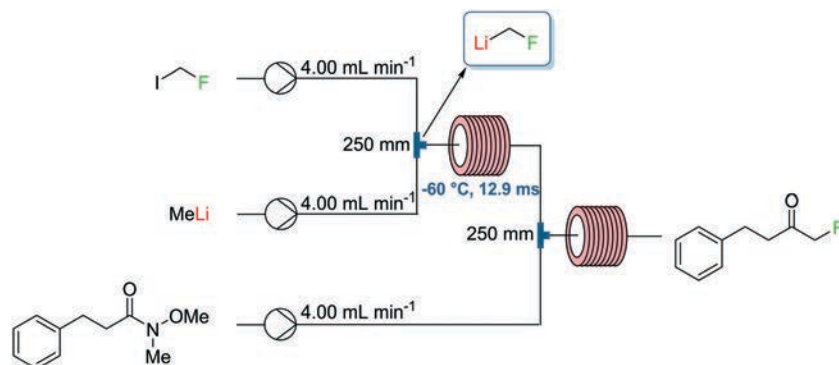

Scheme 17 Generation of an unstable lithium intermediate and its utilization under continuous-flow conditions (adapted from ref. 113).

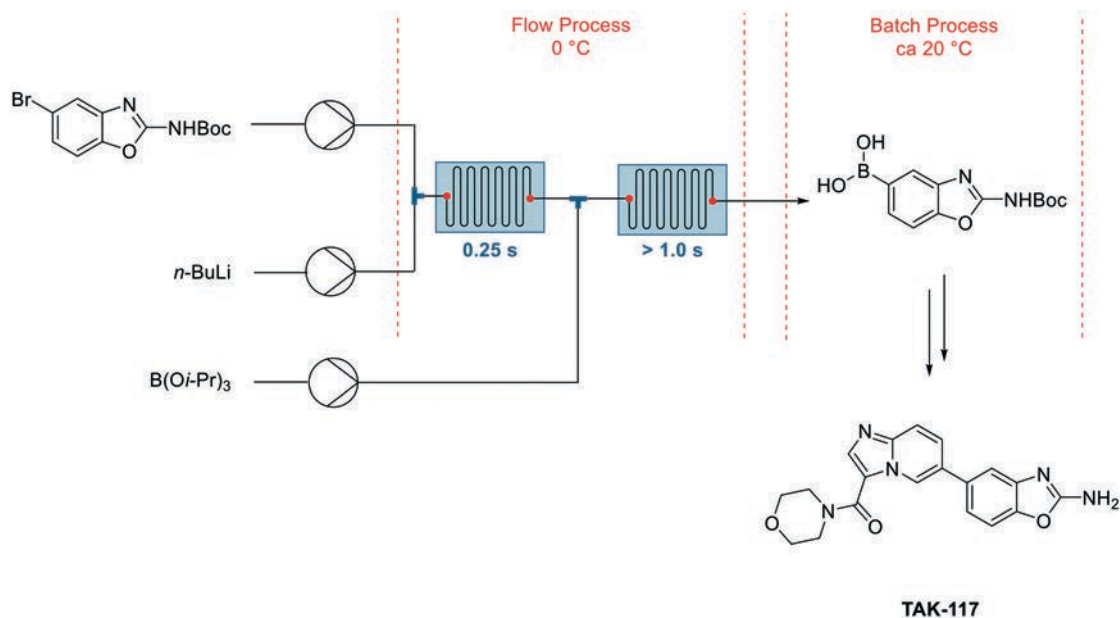

Scheme 18 Continuous-flow synthesis of boronic acid under flash conditions and its utilization in batch to prepare a selective PI3K α inhibitor (adapted from ref. 114).

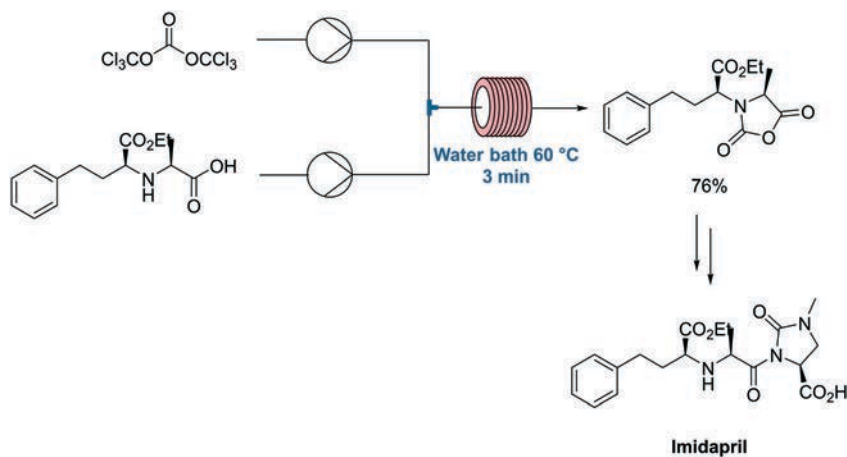

Scheme 19 Synthesis of imidapril under flow conditions (adapted from ref. 115).

can be applied due to the better control of the mass and heat transfer. In this regard, we want to highlight the example from Mitsuda and co-workers,¹¹⁵ who developed a continuous-flow synthesis protocol for a *N*-carboxy anhydride, a key intermediate for the synthesis of the antihypertensive drug imidapril, using phosgene as a building block, with a residence time $\tau = 3$ min (Scheme 19). This procedure not only allows an optimal reaction yield but also prevents safety issues bound to phosgene toxicity.

Continuous-flow approaches could also be useful to carry out slow or very slow reactions, with $\tau > 15$ min, when the reaction involves hazardous reagents or dangerous gases (e.g., H₂, CO, phosgene, etc.). These gases could be safely prepared and consumed *in situ* under flow conditions. Examples of transformative flow applications of hazardous reactions include high-pressure hydrogenations (Scheme 20A),¹¹⁶ fluorinations (Scheme 20B),¹¹⁷ carbonylations (Scheme 20C),¹¹⁸ syntheses of unstable azides¹¹⁹ and their exploitation in heterocycle synthesis.¹²⁰

The importance of pressure

Differently from batch reactors, flow systems can be easily pressurized, working at supercritical solvent conditions. This is possible using a back-pressure regulator typically applied near the exit of the stream. In 2016, Monteiro *et al.* developed a continuous-flow synthesis of the hydantoin scaffold, whose major challenge was the solubility of the starting materials and the formation of explosive gaseous bubbles as a result of reagent evaporation (Scheme 21).¹²¹ These issues were solved in flow mode by using back-pressure regulators of 20 bar total pressure to avoid evaporation and keep the reagents in solution.

The importance of 'solution-diffusion'

Reactions involving heterogeneous gas-liquid mixtures (such as those employing 'waste' CO₂ as a reactant) could be conveniently carried out in tube-in-tube reactors. These peculiar reactors are made of two tubular channels, one

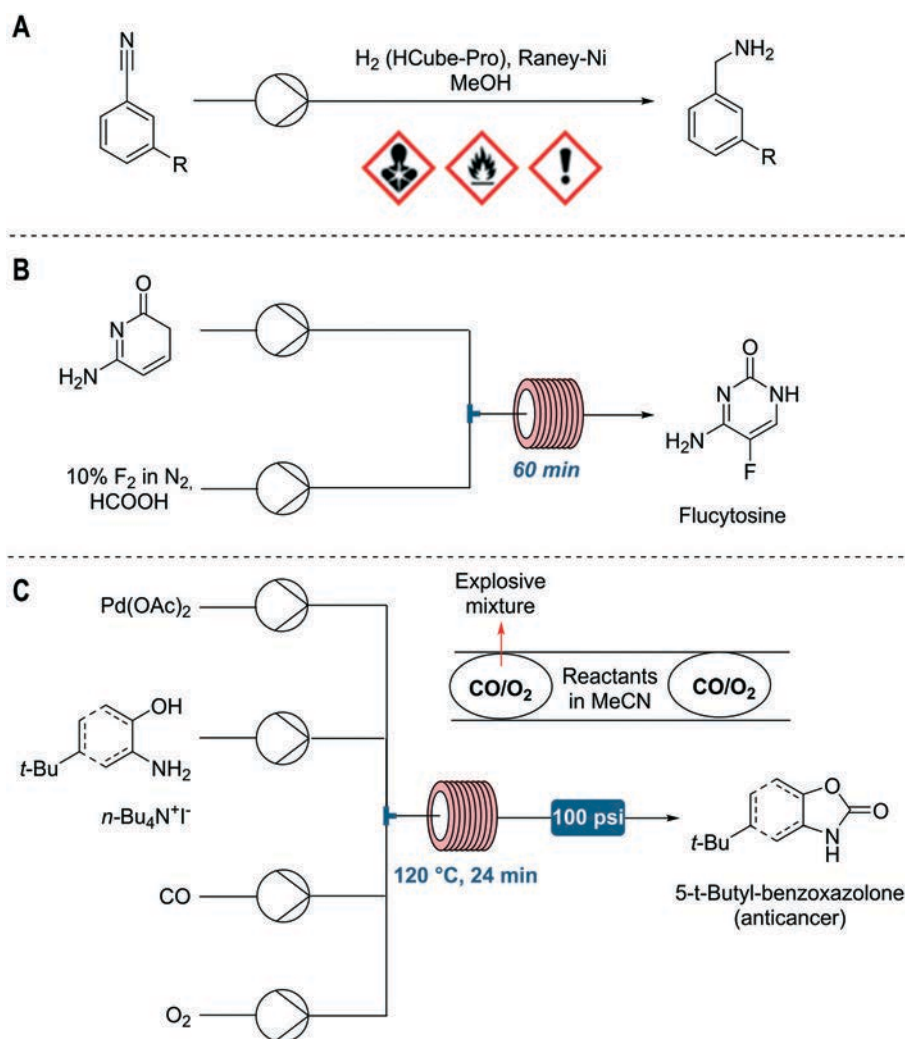

Scheme 20 (A–C) Selected examples of hazardous reactions in continuous-flow mode (adapted from ref. 116–118). Flow chemistry provides in this case a tool to safely perform these reactions.

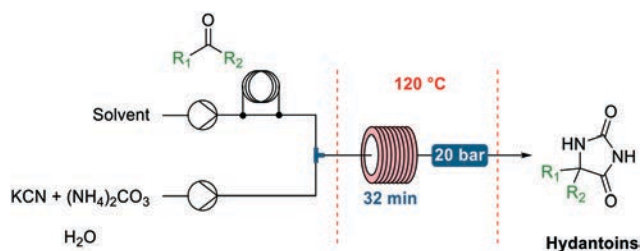

Scheme 21 Synthesis of hydantoins under high-temperature and high-pressure continuous-flow conditions (adapted from ref. 121)

inside the other, separated by a polymeric membrane. Common membrane polymers are cellulose triacetate, polyisoprene, polycarbonate, polystyrene, polysulfone, and polytetrafluoroethylene (Teflon). In tube-in-tube reactors, the gas phase can thus flow in the external tube (conventional tube-in-tube configuration, Fig. 9A) or in the gas-permeable internal tube (reverse tube-in-tube reactors, Fig. 9B).¹²² In both cases, the working principle of these membranes is called ‘solution-diffusion’, since the solute (the gas) dissolves in the polymer (solution) and moves then through the polymer chain gaps (diffusion).

Kappe and co-workers used a tube-in-tube reactor for the generation, separation, and usage of anhydrous diazomethane in a continuous-flow process (Scheme 22).¹²³ The gaseous diazomethane was generated in the inner gas-permeable tube, permeated outside through the membrane, and reacted with the other substrates in the liquid phase.

Similarly, O'Brien, Ley, and Polyzos developed a continuous-flow process for the CO-mediated methoxycarbonylation reactions, using a tube-in-tube reactor with Teflon AF-2400 tubing (Scheme 23).¹²⁴ The utility of this reactor configuration was proven by the possibility to safely handle hazardous gases like CO, making it an ideal carbonyl source in C–C bond formation reactions.

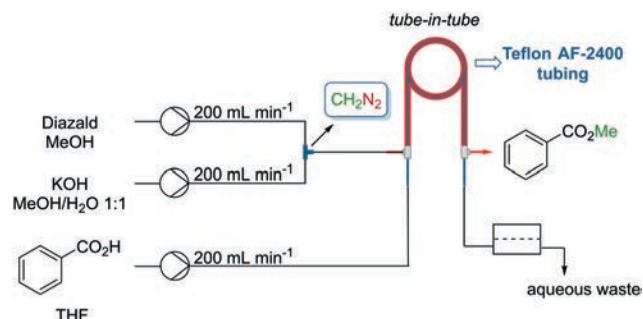

Scheme 22 Continuous-flow generation and reactions of anhydrous diazomethane using a tube-in-tube reactor (adapted from ref. 123).

The importance of mixing

Many important reactions within the field of circular chemistry and material manufacturing are affected by mixing (see, for instance, Fig. 6). Typically, the fluid dynamics in microreactors is laminar, with a Reynolds number of less than 2300; hence, mixing occurs by diffusion. In the case of biphasic reactions, when the reagents are immiscible liquids or we have a suspension, mixing can be improved, creating local turbulent conditions using micromixers. Static micromixing structures increase mass transfer, allowing turbulent flow conditions. Multilamination of streams in a channel with corrugated walls increases the contact surface of lamellar streams and leads to fast mixing. There are a lot of configurations for static micromixing structures, like tangential, SZ shaped, and caterpillar (Fig. 10). Reactors with static mixers can also be 3D-printed with the possibility to obtain intricate details in mm-sized channels.

Blacker and Jolley reported a continuous-flow synthesis of *N*-chloro-*N,N*-dialkylamine solutions in a nylon-PTFE tubular reactor, presenting static mixers that improved phase transfer

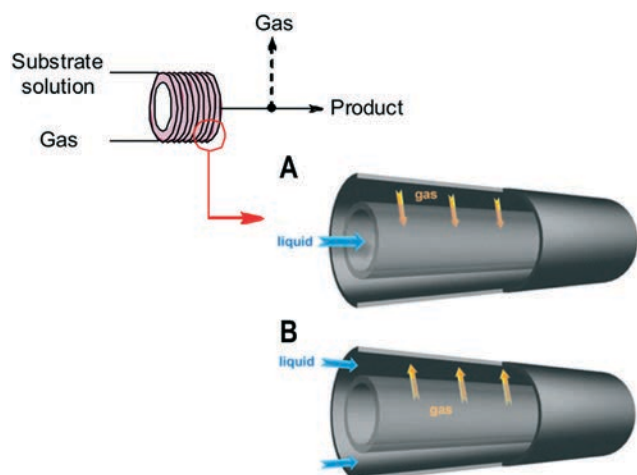
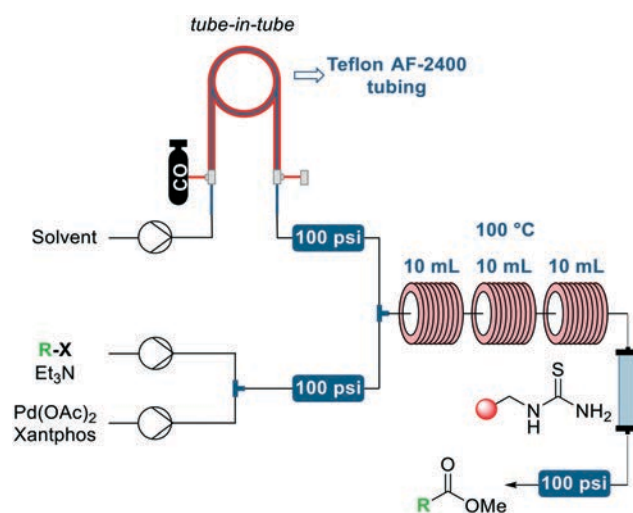

Fig. 9 Structure of a tube-in-tube reactor with its two (A-B) characteristic operating mode (adapted from ref. 122).



Scheme 23 Continuous-flow methoxycarbonylation in tube-in-tube reactor (adapted from ref. 124).

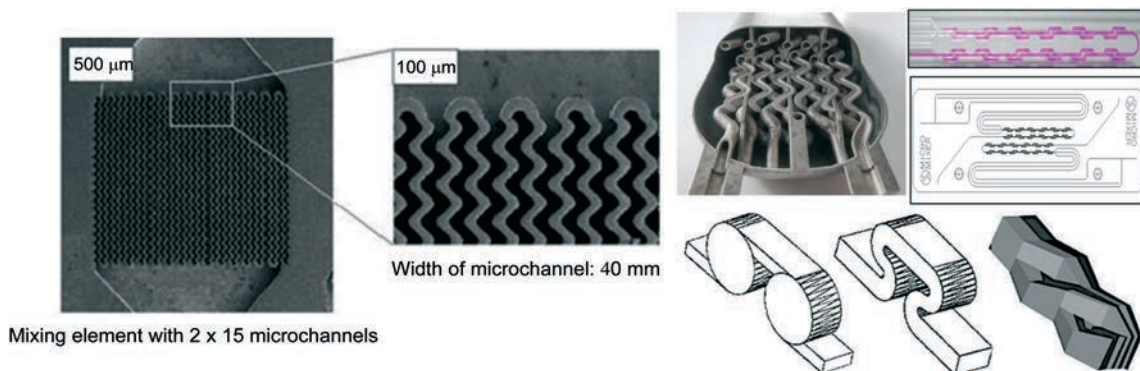
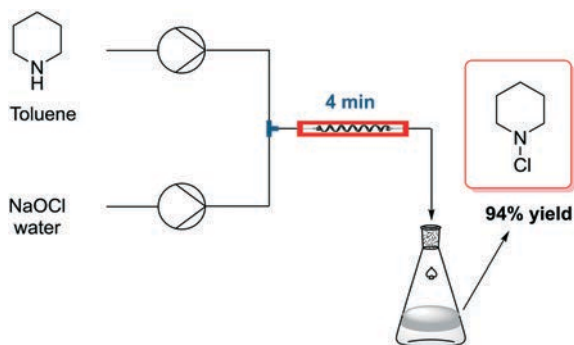

Fig. 10 Details and 3D models of conventional static micromixing structures.



Scheme 24 Mesoscale static mixer setup for continuous *N*-chloramine synthesis (adapted from ref. 125).

between biphasic solutions (Scheme 24).¹²⁵ Both organic and aqueous phases were pumped simultaneously with equal flow rates into a T-mixer, forming a well-mixed emulsion as long as solutions flow into the static mixers and rapidly separate shortly after emerging from the mixing region. Such configurations could find useful applications in polymerizations.

The importance of selecting the right pump

The assembly of a flow process for a specific reaction is strongly affected by the choice of the pumping system, which provides a continuous stream of reagents and avoids clogging of the system. The choice of the pump depends not only on the operating pressure, temperature, and flow rates but also on the volumes that must be injected and the features of the substances that must be pumped (*i.e.*, viscosity and chemical compatibility among others). There are several types of pumps and these are typically classified into three macrogroups: reciprocating pumps, rotary-type pumps, and pneumatic pumps. Among reciprocating pumps, there are piston (syringe) pumps that have been widely used in the past and are still used in more than 90% of all chemical processes. They consist of a small chamber in which substances are pumped by the back/

forth motion of a motor-driven piston made of inert material like ceramics or stainless steel (Fig. 11A). These types of pumps can operate at high output pressures (up to 10 000 psi) and ensure constant flow rates, but they are not suitable for emulsions and slurries. Among the rotary types, we have peristaltic pumps. These units are suitable for a broad range of fluids, including viscous materials that cannot be pumped by common pumps; they also enable contamination-free fluid transfer. Peristaltic pumps are positive displacement pumps in which the fluid passes through a flexible tube fitted inside a circular cavity. In this chamber, rollers rotated by suitable motors push the fluids through the tube by physically compressing it (Fig. 11B). Differently from every other system, these pumps can be used for slurries, but the common issues are pulsations and limitations with reaching flow rates over 10 mL min⁻¹.¹²⁶ Pneumatic pumps, which use compressed air to create force that is used to move fluids through a piping system, are not often used to process fluids in flow microreactors.

The importance of novel process windows

The use of flow technologies has provided a platform for the resurgence of interest in photochemistry and electrochemistry¹⁴⁷ due to a more efficient energy transfer within the narrow reaction channels. This is allowed by the easy modularity and the possibility to obtain customized reactors for every kind of reaction, solving the low homogeneity of reaction conditions, and opening up a whole range of novel and scalable transformations for the bench chemist. Examples include, among others, cycloadditions, C–C couplings and alkylations *via* photoredox catalysis in flow regime, and the electrochemically driven formation of sulfonyl fluorides, sulfoxides, and sulfones (Scheme 25).^{127,128,147} We expect that in the near future such methods can also be implemented to recover waste chemicals (such as H₂S) and obtain polymers and new nanocatalysts *via* photochemical and electrochemical routes.

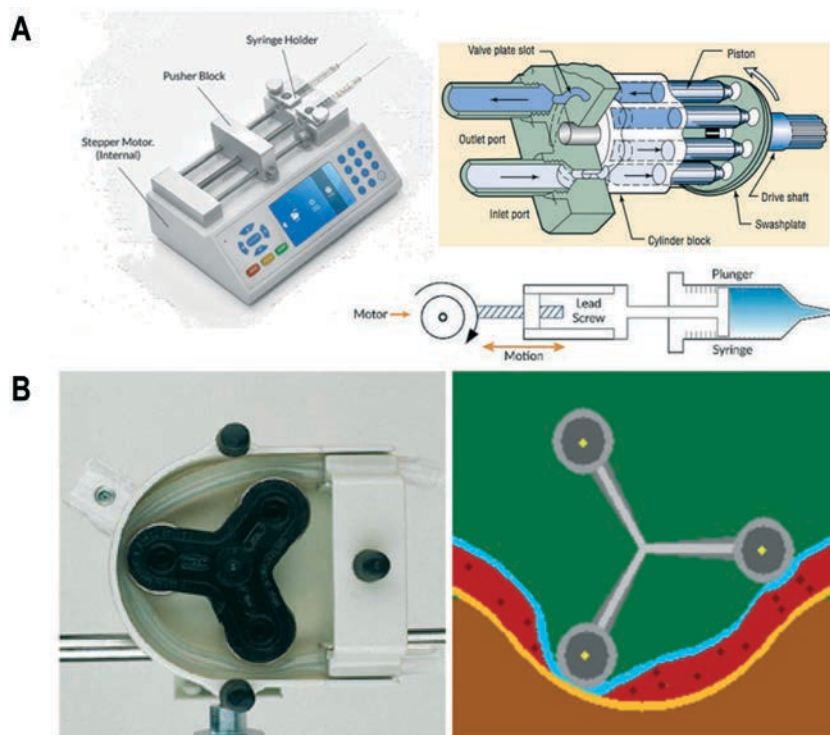
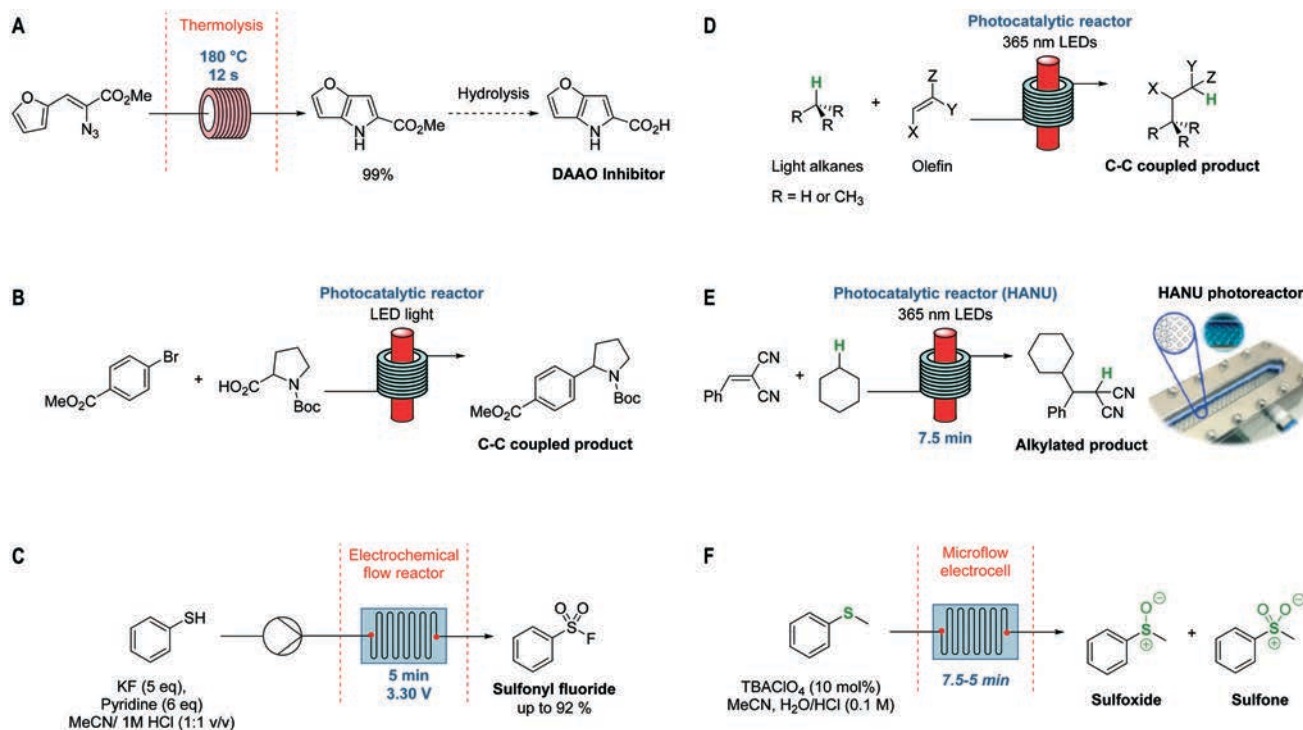

Fig. 11 Examples of syringe (A) and peristaltic (B) pumps typically used for flow chemistry applications.



Scheme 25 (A–F) Examples of new processes enabled due to flow chemistry (adapted from ref. 127, 128 and 147).

6. Automation for novel flow methods

In the setting where flow chemistry is now expanding, covering the circular synthesis of chemicals and the

manufacturing of nanomaterials, machines and new enabling technologies will continue to play a critical role, facilitating the identification of novel reactor geometries and avoiding redundant operations.

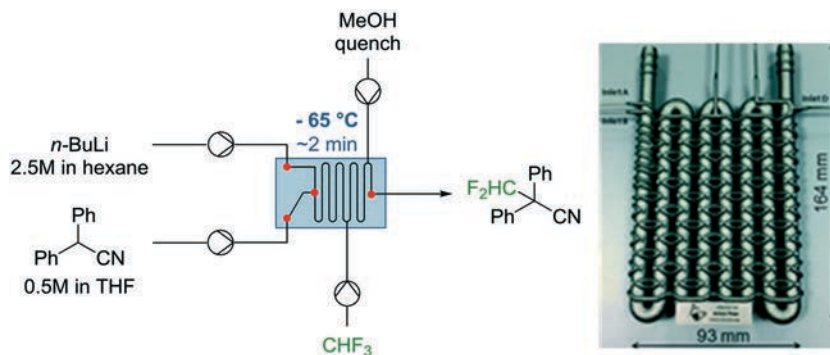

Scheme 26 Difluoromethylation reaction using fluoroform in a 3D-printed flow reactor (adapted from ref. 129) and characteristic lengths of the 3D printed reactor.

Additive manufacturing

Additive manufacturing is revolutionizing production. However, to integrate this powerful technology into new research areas, manufacturers need to rethink the design of their processes and consider where additive manufacturing can bring value compared to traditional mould or subtractive manufacturing. The first functional 3D printer was created in 1984 by Chuck Hill.^{129b} Since then, 3D printing has been used to produce human prostheses and tissues, kitchen utensils, musical instruments, toys, and even houses. The chemistry sector has recently taken advantage of this development, and today chemists can easily create their own reactors to meet reaction particularities. In many cases, the performance of a batch or flow reactor depends on the efficiency of the reaction mixture, especially when this involves fast kinetics. For example, let us assume that we are working with a reaction characterized by a Damköhler number (Da) greater than 1 (*i.e.*, this number represents the ratio between the reaction rate and the mass transfer rate by diffusion). In this situation, the reaction is faster than the mass transfer, causing local concentration of reagents that potentially facilitate side reactions. Such a scenario could be strategically overcome after planning and printing a reactor that offers fast mixing. In this sense, Kappe and co-workers 3D-printed a steel flow reactor with three inlets for the difluoromethylation reaction using fluoroform.¹²⁹ The reactor was specifically computer-aided designed to allow fast

reagent mixing and maximize mass transfer and reaction selectivity. During the reactor planning, computational fluid dynamics (CFD) simulation was accessed to evaluate the mixing performance. Practically, fluoroform (CHF_3) was combined with *n*BuLi to generate difluorocarbene ($:\text{CF}_2$) that quickly reacted with the α -position of the substrate. The reaction proceeded at $-65\text{ }^\circ\text{C}$ and with only 2 min of residence time (Scheme 26).

3D printing offers limitless possibilities for reactor design. The fabrication process typically starts creating 3D models by computer-aided design (CAD) software followed by CFD simulation to verify parameters such as geometry and flow behavior. To illustrate this, Gruber-Woelfler and co-workers demonstrated the oxidation of Grignard reagents using O_2 in a 3D-printed stainless steel CSTR cascade reactor (Scheme 27).¹³⁰ The reactor was strategically drawn in CAD to allow the implementation of the sensor ports for the in-line monitoring of the consumption of O_2 by optical fiber sensors. The CFD simulation was also conducted to evaluate the mixing geometry and flow pattern.

It is worth mentioning that 3D-printed flow reactors have a very low cost and could be easily and rapidly made from a CAD drawing. In that way, Benaglia and co-workers evaluated the enantioselective Henry reaction exploring several 3D-printed reactors. These were prepared with variable dimensions, channels, and materials (nylon, PLA, and HIPS) and just within a few minutes.¹³¹ Both conversion and stereoselectivity were affected by the reactor properties; in

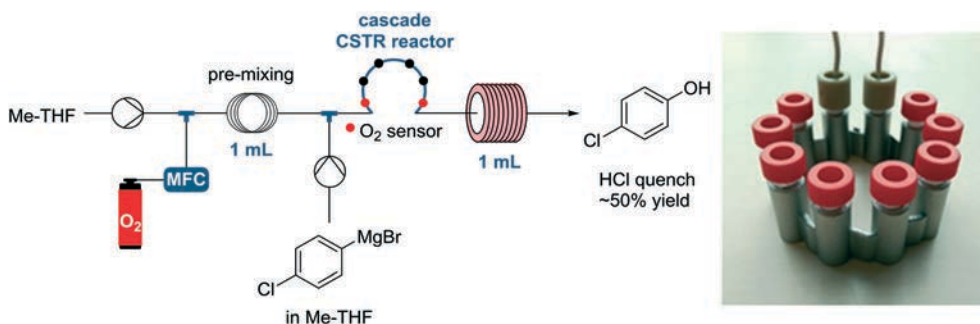

Scheme 27 Oxidation of Grignard reagents using O_2 in a 3D-printed stainless steel CSTR cascade reactor (adapted from ref. 130).

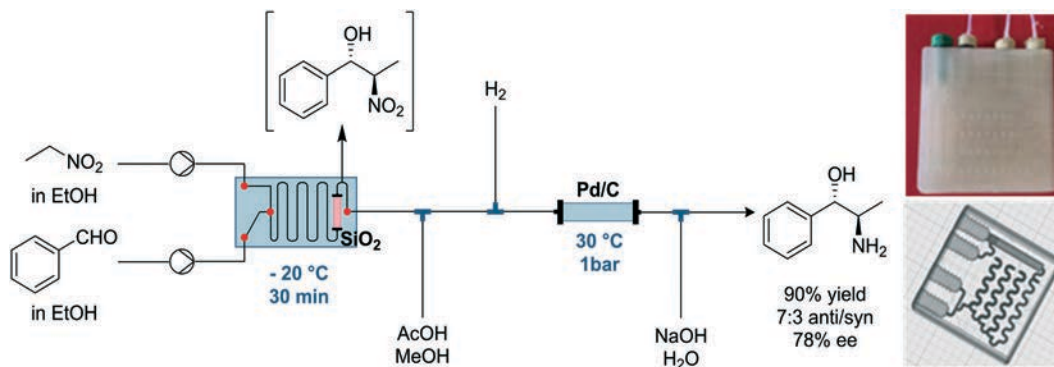

Scheme 28 Henry reaction using a 3D-printed reactor with an internal cavity for SiO₂ to allow in-line purification (adapted from ref. 131).

particular, that made of PLA gave better results (up to 90% ee and 87% yield). The aldol-like products were then subjected to hydrogenation in a commercial-flow setup to generate pharmaceutically active chiral 1,2-amino alcohols (Scheme 28).

These three examples demonstrate the possibility to print individual reaction and mixing zones. However, 3D printing can also be used to manufacture a full platform. Ziegler and co-workers 3D-printed a rack of four syringe pumps and reactors to be used for glycosylation reactions and glycosyl donors.¹³² The pumps were controlled using an Arduino Mega 2560 microcontroller board and such a flow setup could be made for under 300 USD (Scheme 29).

Rabe and co-workers have reported a very interesting study on the chemoenzymatic flow production of 4-hydroxystilbene from *p*-coumaric acid.¹³³ Phenacrylate decarboxylase enzymes and agarose solution were mixed in a cartridge to form a bio-ink that was used as a filament to manufacture a biocatalytic reaction module. Note that the reaction took place by pumping the substrate through the disks. In a second and separate stage, the product was used for a Heck reaction. Despite the low scale and low yield (14.7%), we believe that this study still brings an innovative concept regarding the use of 3D printing for organic synthesis (Fig. 12).

3D printing has been strategically used in many other areas within organic synthesis. For example, Babich and co-

workers 3D-printed an automated synthesis unit (ASU) that allowed less radiation exposure for the synthesis of radioligands containing ⁶⁸Ga, ¹⁸F, and ¹¹C (radioactive PET tracers).¹³⁴ Neumaier and co-workers explored the synthesis of PET tracers in a 3D-printed ASU made of PEEK.¹³⁵ The authors applied a Villiermaux–Dushman protocol to estimate the mixing efficiency for the multistep synthesis of clofarabine precursor. Hilton and co-workers demonstrated the synthesis of bicyclic and tetracyclic heterocycles using commercial equipment with 3D-printed polypropylene column reactors.¹³⁶ Microwave cells can also be 3D-printed and adapted for organic synthesis under a flow regime. Say and co-workers reported the acetylation of amines using a 3D-printed microwave flow cell in excellent yields (92–96%).¹³⁷ Overall, these examples highlight that additive manufacturing technologies such as 3D-printing are opening new opportunities in terms of production paradigm and manufacturing possibilities. Manufacturing lead times are reduced substantially and new reactor designs are produced more quickly.

Integration with artificial intelligence

Repetitive and exhaustive operations, such as reaction condition screening or product purification and

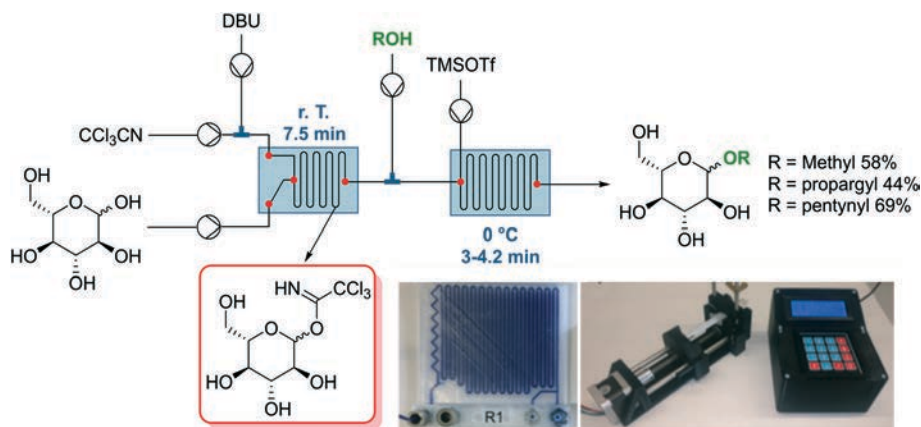

Scheme 29 3D-printed reactor and rack for syringe pump for glycosylation reactions (adapted from ref. 132).

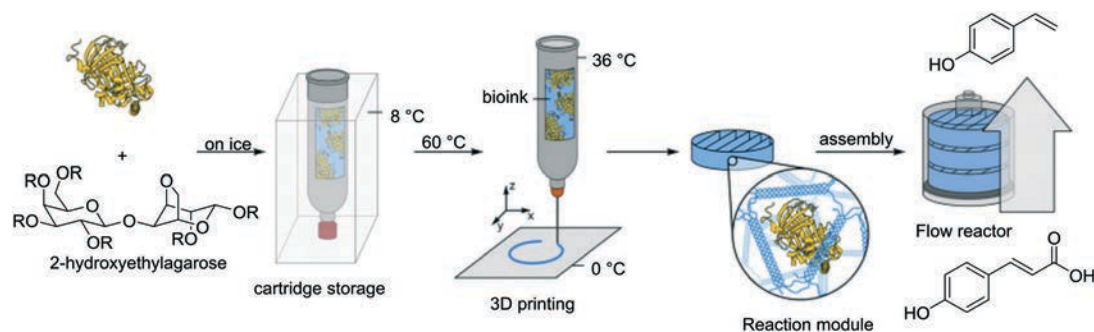

Fig. 12 Chemoenzymatic reaction using a mixture of agarose/enzyme as a filament for the 3D printer to manufacture biocatalytic module disks (adapted from ref. 133).

characterization during chemical and nanomaterials synthesis, can be automatized, also thanks to the advances in the field of robotics. This would make laboratory activities more flexible, guaranteeing parallel testing, high-throughput screening, scale-up production of chemicals and materials, and the consequent development of libraries of novel compounds. Furthermore, a flexible and standardized workplace would avoid repeated work done by operators, enhancing quality.¹³⁸ Finally, the idea to perform remote control of a chemical reaction would allow developing a chemical cloud able to connect the workload across robots

and networks, permitting the innovation and validation of novel procedures and standardization of possible discoveries.

There is not a standardized and universal method to apply automation in chemical and materials synthesis. Yet, recent advances in flow chemistry, robotics, and chemical programming language have facilitated the assimilation of automation at the bench. Steiner *et al.* reported a first example for the chemical sciences.¹³⁹ The authors, in particular, developed a system called 'Chemputer' (Fig. 13) that was able to read multistep organic synthesis protocols from a publication and reproduce it at the bench using a modular system with

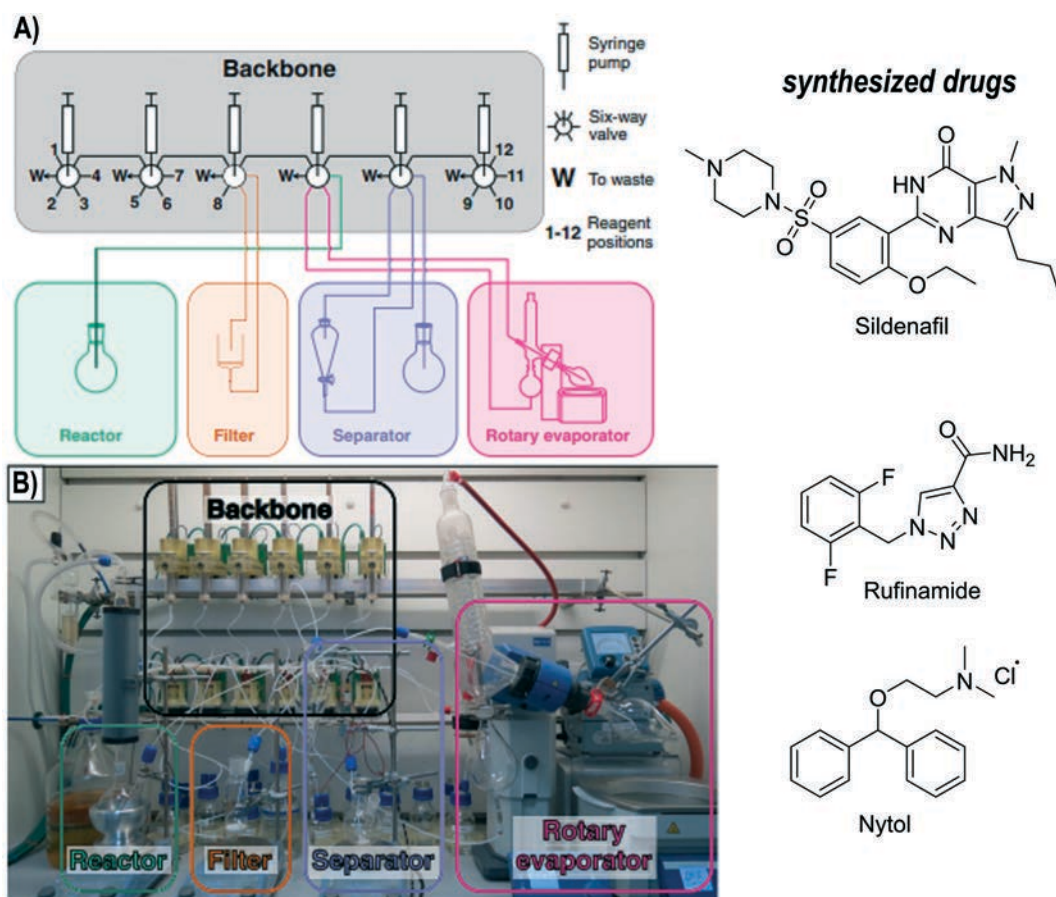

Fig. 13 Scheme of the 'Chemputer' software (A) and automated modular system (B) used for the synthesis of pharmaceuticals (adapted from ref. 139).

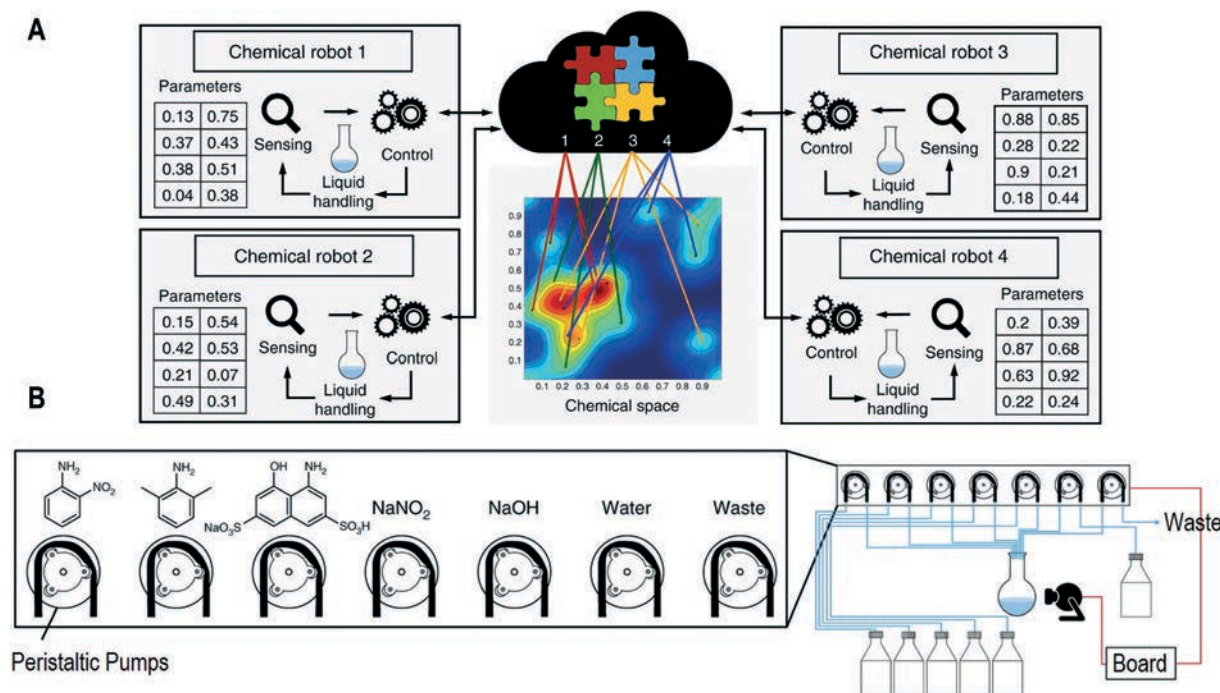

Fig. 14 Scheme of networking platform (A) and peristaltic pump interconnections and control system (B) for flow chemistry applications (adapted from ref. 140).

hardware and software. In particular, in this example they applied a standard chemical programming language, such as ChASM and GraphML, to regulate the backbone of the system *via* a binary on-off control of valves, pumps, reactors, work-up setups, and separation units (Fig. 13). Three pharmaceutical compounds (diphenhydramine hydrochloride, rufinamide, and sildenafil) were finally synthesized without any manual handling and using the principles of flow chemistry.

Cronin and colleagues started from this early example to develop an improved chemical platform able to build a standard set of protocols *via* two internet-connected robots, exploring pharmaceutically relevant azo-coupling reactions.¹⁴⁰ The system featured real-time networking (Fig. 14A) designed using pcDuino3 and a control software platform in Python to control the sensor and the robot system. A certain number of peristaltic pumps provided liquid handling, and they were connected to a driver board and a sensor array equipped with a webcam (Fig. 14B). The data were communicated through a Wi-Fi connection and collected inside a server.

Gilmore and co-workers demonstrated how multi-port valves can be strategically employed for automated radial synthesis of rufinamide and libraries of rufinamide derivatives.¹⁴¹ The advantage of radial synthesis with such a 16-port valve is that there is no requirement of reconfiguration between different synthetic processes in flow. For rufinamide synthesis, the authors compared convergent and linear syntheses. In the convergent pathway, the stable azide **ii** and amide **iv** were prepared and initially stored in the reagent delivery system (RDS). The streams containing **ii**

and **iv** were then combined with CuI for the cyclization reaction (sequence R-R, R-S → S-C). Thus, rufinamide was obtained in 70% yield in three steps. For the linear pathway, azide **ii** was generated and promptly reacted with alkyne **iii** in the presence of CuI followed by amination reaction to generate rufinamide. In-line dilution from 1.5 to 1 M was required due to the insolubility of triazole **vi**. The product was obtained in 45% isolated yield (sequence R-S → S-S → S-C). Note that both convergent and linear syntheses were performed without the reconfiguration of the flow setup (Scheme 30). The same module was used for the synthesis of rufinamide derivatives. The key difference between the methodologies was the precipitation of the intermediate **vi** in the linear mode. In the convergent pathway, the triazole core was generated and precipitated at the end of the sequence, allowing higher reaction concentration as well as productivity.

Jensen, Jamison and co-workers demonstrated a robotically reconfigurable flow platform controlled by artificial intelligence for the synthesis of small molecules.¹⁴² The idea of this study was to showcase a robotically interchangeable plug-and-play flow system for a desired synthesis process. Computer-aided synthesis planning was used for retrosynthesis prediction and condition recommendation. The software contained millions of reactions obtained from the U.S. Patent Trademark Office or tabulated in Reaxys.¹⁴³ The focus of such a platform was the synthesis of APIs and 15 commercial drugs were explored for this purpose. Initially, the software analyzed the drug retrosynthesis and suggested starting materials and general

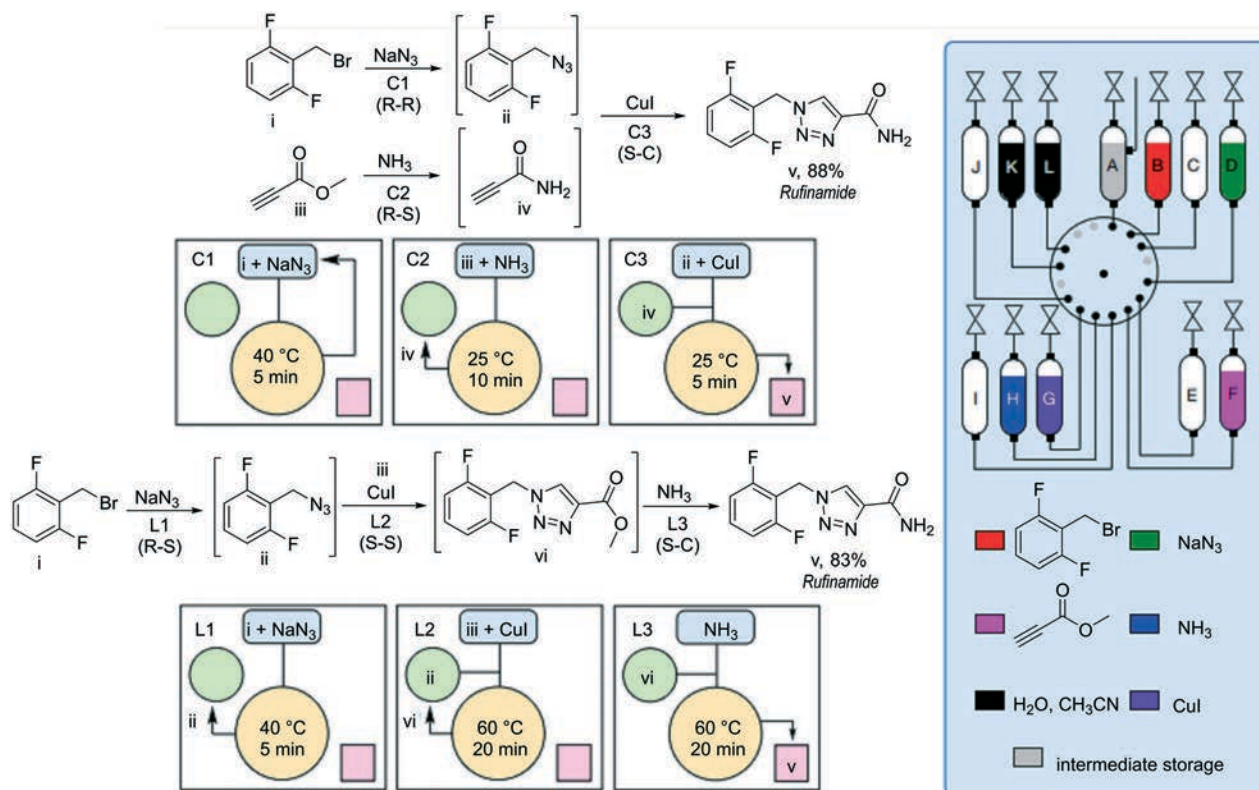

Scheme 30 Convergent and linear synthesis of rufinamide using a radial flow setup (adapted from ref. 141).

conditions for the synthesis. Information such as flow rate, concentration, temperature, and process stack configurations were then manually inserted in the software.

Fig. 15 shows the exemplified synthesis of aspirin, secnidazole, lidocaine, diazepam, (*S*)-warfarin, and safinamide. The robotic platform was also used to prepare

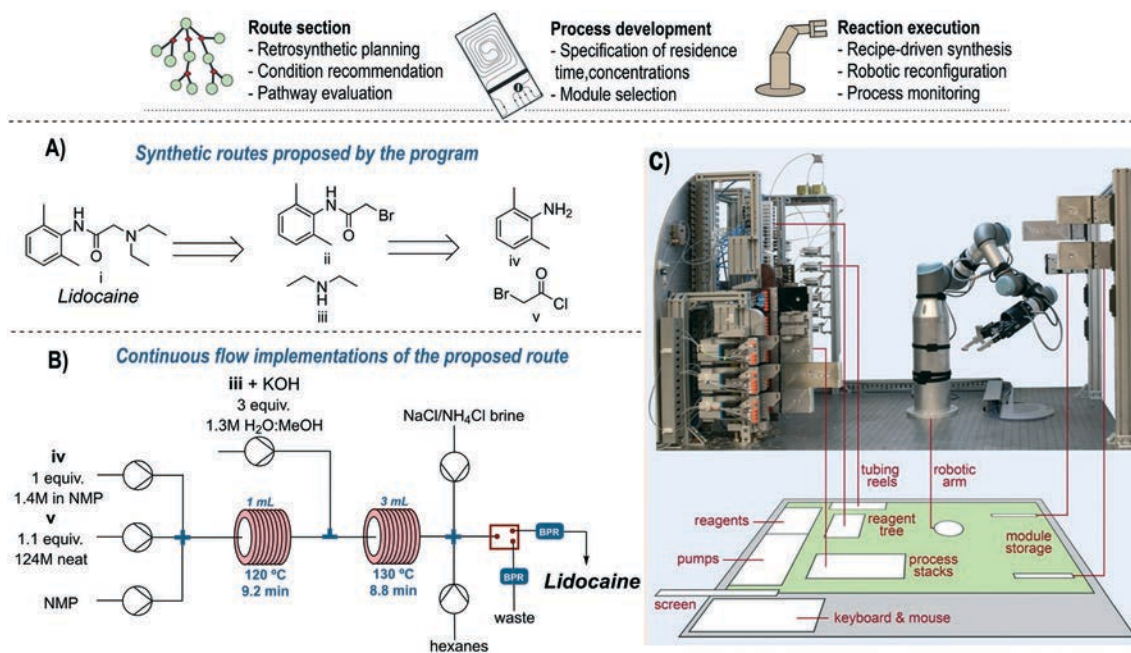

Fig. 15 Robotically interchangeable flow system controlled by artificial intelligence for the synthesis of drugs. The figure, in particular, shows the synthetic routes proposed by the artificial intelligence software (A), the flow process for the suggested pathways (B), and the robotically configured flow setup for each drug synthesis (C) (adapted from ref. 143).

libraries of angiotensin-converting-enzyme inhibitors and nonsteroidal anti-inflammatory drugs.

Similarly, Ley and co-workers reported an automatized continuous-flow platform handled by remote servers.¹⁴⁴ Using servers in Japan, a researcher situated in Los Angeles, USA, was able to manage the synthesis of three drugs (tramadol, lidocaine, and bupropion) in laboratories located in Cambridge, UK.

Overall, now that flow chemistry is expanding in new directions, finding applications for the circular synthesis of chemicals and the manufacturing of nanomaterials, it is expected that machines will play a critical role, helping in making molecules or nanomaterials. Computational methods can play a pivotal role in validating structure–activity relationships, even if current theoretical models still lack from several drawbacks (*e.g.*, the analysis of the nanomaterial performance by density functional theory is often done in vacuum without considering solvent effects). Molecular fingerprints are now emerging as a new way to represent in a unique manner a molecule as a mathematical object. These show chemical characteristics based on molecular force fields, volume or surface properties, and pharmacophore models, reaching a more precise molecular description.^{145,146} We believe that these will find widespread application in predicting material performance and behaviors based on an initial data set available in the literature.

7. Conclusions and outlook

Public perception of chemistry is often associated with the image of pollution. Miniaturization, automatization, and parallelization are transforming the way we perceive chemistry, fostering innovations in how chemical manufacturers plan, construct, operate, and integrate chemical plants. This is providing several advantages in terms of safety, efficiency, and sustainability. We believe that the relevance of flow chemistry will continue to expand in the years to come, bringing its advantages to other fields, including circular processing and nanomaterial synthesis. The plants of the future could thus be fully continuous, digital, compact, eco-friendly, and resource-efficient; a place where the catalysts used to make the chemical steps and the polymers applied to make the reactors are also prepared in continuous mode, and where machines speak to each other, and automation, simulation, visualization, and analytics are deployed vividly to eliminate waste generation and increase process efficiency.

There might still be challenges associated with the use of flow chemistry for chemical manufacturing. Other aspects involve the exploitation of flow chemistry in novel research areas, particularly those that are within the broad field of circular chemistry and can provide a route to convert ‘waste’ starting materials into value-added products. Also in this case, the use of flow chemistry for the automated and controlled synthesis of materials and catalysts could open up complete new synthetic methods and process windows which are still difficult to foresee. Among the challenges, it is often

difficult to integrate downstream purification methods with upstream reaction systems since miniaturized work-up and purification setups are not readily available, although we acknowledge some efforts using membrane-based liquid/liquid separators.¹¹ This integration requires as well standardized machines and standardization efforts. For this reason, we expect, for the decade to come, the commercialization of continuous work-up utilities together with absorption units and miniaturized chromatography setups. Overall, the field looks very bright and the examples highlighted in this critical review confirm that some of the technical features to solve these challenges are already among us.

Conflicts of interest

There are no conflicts to declare.

Acknowledgements

The authors gratefully acknowledge financial support from the Fondazione Politecnico di Milano, the Fondazione Bracco (GV, Felder award), the Bracco Spa (AS), the São Paulo Research Foundation – FAPESP (JCP, awards no. 2014/26378-2 and 2014/25770-6; GRG, award no. 2018/09861-2), and the Coordination for the Improvement of Higher Education Personnel – CAPES (RSG). GV is indebted to Dr. Sylvia Richard-Bildstein (Idorsia Pharmaceuticals Ltd) for the many pleasant discussions about flow chemistry and other enabling technologies over the years.

References

- (a) J. Williams and C. O. Kappe, *Curr. Opin. Green Sustain. Chem.*, 2020, **10**, 100351; (b) S. V. Ley, Y. Chen, D. E. Fitzpatrick and O. May, *Chimia*, 2019, **73**, 792; (c) C. Sambigioglio and T. Noël, *Trends Chem.*, 2020, **2**, 92; (d) Z. Peng and J. L. Jimenez, *Chem. Soc. Rev.*, 2020, **49**, 2570; (e) M. K. Sharma, J. Raval, G.-N. Ahn, D.-P. Kim and A. A. Kulkarni, *React. Chem. Eng.*, 2020, **5**, 838; (f) M. Trojanowicz, *Molecules*, 2020, **25**, 1434; (g) M. Elsherbini and T. Wirth, *Acc. Chem. Res.*, 2019, **52**, 3287; (h) J. M. De Souza, R. Galaverna, A. A. N. De Souza, T. J. Brocksom, J. C. Pastre, R. O. M. A. De Souza and K. T. De Oliveira, *An. Acad. Bras. Cienc.*, 2018, **90**, 1131.
- M. B. Plutschack, B. Pieber, K. Gilmore and P. H. Seeberger, *Chem. Rev.*, 2017, **117**, 11796.
- B. Gutmann, D. Cantillo and C. O. Kappe, *Angew. Chem., Int. Ed.*, 2015, **54**, 6688.
- (a) J. A. Newby, W. Blaylock, P. M. Witt, J. C. Pastre, M. K. Zacharova, S. V. Ley and D. L. Browne, *Org. Process Res. Dev.*, 2014, **18**, 1211; (b) V. Hessel, D. Kralisch, N. Kockmann, T. Noël and Q. Wang, *ChemSusChem*, 2013, **6**, 746.
- (a) T. N. Glasnov and C. O. Kappe, *Org. Biomol. Chem.*, 2018, **16**, 5946; (b) B. Gutmann, D. Cantillo and C. O. Kappe, *Angew. Chem., Int. Ed.*, 2015, **54**, 6688; (c) F. Fanelli, G. Parisi, L. Degennaro and R. Luisi, *Beilstein J. Org. Chem.*, 2017, **13**, 520; (d) P. Musci, M. Colella, A. Sivo, G. Romanazzi, R. Luisi and L. Degennaro, *Org. Lett.*, 2020, **22**,

- 3623; (e) M. Colella, A. Nagaki and R. Luisi, *Chem. – Eur. J.*, 2020, **26**, 19.
- 6 J. Wegner, S. Ceylan and A. Kirschning, *Adv. Synth. Catal.*, 2012, **354**, 17.
- 7 M. C. F. C. B. Damião, R. Galaverna, A. P. Kozikowski, J. Eubanks and J. C. Pastre, *React. Chem. Eng.*, 2017, **2**, 896.
- 8 M. C. F. C. B. Damião, H. M. Marçon and J. C. Pastre, *React. Chem. Eng.*, 2020, **5**, 865.
- 9 (a) J. C. Pastre, D. L. Browne and S. V. Ley, *Chem. Soc. Rev.*, 2013, **42**, 8849; (b) S. V. Ley, *Chem. Rec.*, 2012, **12**, 378; (c) A. Gioiello, V. Mancino, P. Filippini, S. Mostarda and B. Cerra, *J. Flow Chem.*, 2016, **6**, 167; (d) B. Cerra, F. Mangiavacchi, C. Santi, A. M. Lozza and A. Gioiello, *React. Chem. Eng.*, 2017, **2**, 467; (e) A. Gioiello, A. Piccinno, A. M. Lozza and B. Cerra, *J. Med. Chem.*, 2020, **63**, 6624.
- 10 (a) I. R. Baxendale, J. Deeley, C. M. Griffiths-Jones, S. V. Ley, S. Saaby and G. K. Tranmer, *Chem. Commun.*, 2006, 2566; (b) L. Dalla-Vechia, B. Reichart, T. Glasnov, L. S. M. Miranda, C. O. Kappe and R. O. M. A. de Souza, *Org. Biomol. Chem.*, 2013, **11**, 6806.
- 11 A. Adamo, R. L. Beingessner, M. Behnam, J. Chen, T. F. Jamison, K. F. Jensen, J. C. M. Monbaliu, A. S. Myerson, E. M. Revalor and D. R. Snead, *et al.*, *Science*, 2016, **352**, 61.
- 12 A. Chanda, A. M. Daly, D. A. Foley, M. A. LaPack, S. Mukherjee, J. D. Orr, G. L. Reid, D. R. Thompson and H. W. Ward, *Org. Process Res. Dev.*, 2015, **19**, 63.
- 13 U.S. Department of Health and Human Services - Food and Drug Administration, *Quality Considerations for Continuous Manufacturing*.
- 14 E. Palmer, *GSK opens \$95M continuous production operation in Singapore*, Available at: <https://www.fiercepharma.com/manufacturing/gsk-opens-130m-continuous-production-facilities-singapore> (accessed 29 June 2020).
- 15 E. Palmer, *Glaxo to use new technology in India plant*, Available at: <https://www.fiercepharma.com/partnering/glaxo-to-use-new-technology-india-plant> (Accessed 20 November 2020).
- 16 K. P. Cole, J. M. Groh, M. D. Johnson, C. L. Burcham, B. M. Campbell, W. D. Diserod and M. R. Heller, *et al.*, *Science*, 2017, **356**, 1144.
- 17 Eli Lilly, *Meet Eli Lilly and Company - 2019 Facility of the Year Process Innovation Category Winner*, Available at: <https://ispe.org/pharmaceutical-engineering/ispeak/meet-eli-lilly-andcompany-2019-facility-year-process-innovation> (Accessed 04 July 2020).
- 18 E. Godineau, C. Battilocchio and M. Lal, *Chimia*, 2019, **73**, 828.
- 19 Z. Brennan, *FDA calls on manufacturers to begin switch from batch to continuous production*, Available at: <https://www.outsourcing-pharma.com/Article/2015/05/01/FDA-calls-on-manufacturers-to-begin-switch-from-batch-to-continuous-production>, (Accessed 05 July 2020).
- 20 (a) A. Harsanyi, A. Conte, L. Pichon, A. Rabion, S. Grenier and G. Sandford, *Org. Process Res. Dev.*, 2017, **21**, 273; (b) B. Desai, K. Dixon, E. Farrant, Q. Feng, K. R. Gibson, W. P. van Hoorn, J. Mills, T. Morgan, D. M. Parry, M. K. Ramjee, C. N. Selway, G. J. Tarver, G. Whitlock and A. G. Wright, *J. Med. Chem.*, 2013, **56**, 3033.
- 21 J. Keenan, *Cambrex caps latest addition of continuous-flow manufacturing at North Carolina plant*, Available at: <https://www.fiercepharma.com/manufacturing/cambrex-caps-latest-addition-continuous-flow-manufacturing-at-north-carolina-plant>, (Accessed 04 July 2020).
- 22 M. Lynch, *Flexibility, agility and quality assurance: Advantages of continuous manufacturing*, Available at: <https://www.outsourcing-pharma.com/Article/2019/04/10/Janssen-on-the-benefits-of-continuous-manufacture>, (Accessed 05 July 2020).
- 23 P. R. Makgwane and S. S. Ray, *J. Nanosci. Nanotechnol.*, 2014, **14**, 1338.
- 24 K. Loizou, S. Mourdikoudis, A. Sergides, M. O. Besenhard, C. Sarafidis, K. Higashimine, O. Kalogirou, S. Maenosono, N. T. K. Thanh and A. Gavriilidis, *ACS Appl. Mater. Interfaces*, 2020, **12**, 28520.
- 25 L. V. Romashov and V. P. Ananikov, *Chem. – Asian J.*, 2017, **12**, 2652.
- 26 D. Castello, T. H. Pedersen and L. A. Rosendahl, *Energies*, 2018, **11**, 3165.
- 27 (a) T. Maschmeyer and L. J. Humphreys, *Methods for Biofuel Production*, WO2011/123897 A1, 2011; (b) T. Maschmeyer, *Processing of Organic Matter*, WO2012/092644 A1, 12 July 2012; (c) Licella, *Cat-HTR™*, Available at: <https://www.licella.com.au/cat-htr/>, (Accessed 06 July 2020).
- 28 J. Lane, *The Silver in Silva: The Story of Steeper Energy and SGF's \$59M Advanced Biofuels Project in Norway*, Available at: <https://www.biofuelsdigest.com/bdigest/2018/01/16/the-silver-in-silva-the-story-of-steeper-energys-59m-advanced-biofuels-project-in-norway/>, (Accessed on 07 July 2020).
- 29 (a) C. U. Jensen, J. K. Rodriguez Guerrero, S. Karatzos, G. Olofsson and S. B. Iversen, *Biomass Convers. Biorefin.*, 2017, **7**, 495–509; (b) Steeper Energy, *Hydrofaction®*, Available at: <https://steeperenergy.com/hydrofaction/>, (Accessed 06 July 2020).
- 30 (a) A. Bosetti, D. Bianchi, G. Franzosi and M. Ricci, *Process for the Production of Bio-Oil from Solid Urban Waste*, WO2011/030196 A1, 17 March 2011; (b) ENI S.p.A., *Waste-to-fuel*, Available at: <https://www.eni.com/en-IT/operations/waste-to-fuel.html>, (Accessed 08 July 2020).
- 31 (a) Beston (Henan) Machinery Co., Ltd., *Continuous Waste Tyre Pyrolysis Plant*, Available at: <https://www.bestongroup.com/continuous-waste-tyre-pyrolysis-plant/>, (Accessed 08 July 2020); (b) Henan Mingjie Environmental Equipment Co., Ltd., *Fully Continuous Pyrolysis Plant*, https://www.mingjiegroup.com/products/Fully_continuous_pyrolysis_plant.html?gclid=Cj0KCQjw14v4BRDaARISAFjATPkepBDLcIRl0mJTdbMrEiYC8po0GLKQ5gqNeYWCFaHmVxdMa2bcLcQaAo9MEALw_wcB, (Accessed 08 July 2020).
- 32 (a) A. Hommes, H. J. Heeres and J. Yue, *ChemCatChem*, 2019, **11**, 4671; (b) R. Gérardy, R. Morodo, J. Estager, P. Luis, D. P. Debecker and J.-C. M. Monbaliu, *Top. Curr. Chem.*, 2019, **377**, 1.
- 33 (a) T. Keijer, V. Bakker and J. C. Slootweg, *Nat. Chem.*, 2019, **11**, 190; (b) J. C. Slootweg, *Curr. Opin. Green Sustain. Chem.*, 2020, **23**, 61.

- 34 N. Wardenier, Y. Gorbanev, I. Van Moer, A. Nikiforov, S. W. H. Van Hulle, P. Surmont, F. Lynen, C. Leys, A. Bogaerts and P. Vanraes, *Water Res.*, 2019, **161**, 549.
- 35 D. Becker, S. Rodriguez-Mozaz, S. Insa, R. Schoevaart, D. Barcelo, M. de Cazes, M.-P. Belleville, J. Sanchez-Marcano, A. Misovic, J. Oehlmann and M. Wagner, *Org. Process Res. Dev.*, 2017, **21**, 480.
- 36 A. H. Braga, P. Vidinha and L. M. Rossi, *Curr. Opin. Green Sustain. Chem.*, 2020, **26**, 100386.
- 37 T. Siudyga, M. Kapkowski, P. Bartczak, M. Zubko, J. Szade, K. Balin, S. Antoniotti and J. Polanski, *Green Chem.*, 2020, **22**, 5143.
- 38 S. Ren, D. Joulié, D. Salvatore, K. Torbensen, M. Wang, M. Robert and C. P. Berlinguette, *Science*, 2019, **365**, 367.
- 39 E. Jeng and F. Jiao, *React. Chem. Eng.*, 2020, **5**, 1768.
- 40 T. Q. Bui, L. J. Konwar, A. Samikannu, D. Nikjoo and J. P. Mikkola, *ACS Sustainable Chem. Eng.*, 2020, **8**, 12852.
- 41 C. Schotten, D. Plaza, S. Manzini, S. P. Nolan, S. V. Ley, D. L. Browne and A. Lapkin, *ACS Sustainable Chem. Eng.*, 2015, **7**, 1453.
- 42 E. Pfab, L. Filicetto, A. A. Romero and R. Luque, *Ind. Eng. Chem. Res.*, 2019, **58**, 16065.
- 43 (a) Y. M. Questell-Santiago, M. V. Galkin and K. Barta, *et al.*, *Nat. Rev. Chem.*, 2020, **4**, 311; (b) X. Tang, M. Zuo, Z. Li, H. Liu, C. Xiong, X. Zeng, Y. Sun, L. Hu, S. Liu, T. Lei and L. Lin, *ChemSusChem*, 2017, **10**, 2696.
- 44 (a) R. Fang, A. Dhakshinamoorthy, Y. Li and H. Garcia, *Chem. Soc. Rev.*, 2020, **49**, 3638; (b) C. Park and J. Lee, *Green Chem.*, 2020, **22**, 2628; (c) W. Dwi Prasetyo, Z. A. Putra, M. R. Bilad, T. M. I. Mahlia, Y. Wibisono, N. A. H. Nordin and M. D. H. Wirzal, *Polymer*, 2020, **12**, 1091; (d) S. Bertella and J. S. Luterbacher, *Trends Chem.*, 2020, **2**, 440; (e) V. Liberato, C. Benevenuti, F. Coelho, A. Botelho, P. Amaral, N. J. Pereira and T. Ferreira, *Catalysts*, 2019, **9**, 962; (f) E. J. Cho, L. T. P. Trinh, Y. Song, Y. G. Lee and H.-J. Bae, *Bioresour. Technol.*, 2020, **298**, 122386.
- 45 C. A. Hone, P. Lopatka, R. Munday, A. O'Kearney-McMullan and C. O. Kappe, *ChemSusChem*, 2019, **12**, 326.
- 46 R. Galaverna, L. P. Fernandes, D. L. Browne and J. C. Pastre, *React. Chem. Eng.*, 2019, **4**, 362.
- 47 R. Gérardy, D. P. Debecker, J. Estager, P. Luis and J.-C. M. Monbaliu, *Chem. Rev.*, 2020, **120**, 7219.
- 48 (a) R. Galaverna, M. C. Breitzkreitz and J. C. Pastre, *ACS Sustainable Chem. Eng.*, 2018, **6**(3), 4220; (b) S.-H. Pyo, M. Sayed and R. Hatti-Kaul, *Org. Process Res. Dev.*, 2019, **23**, 952; (c) W. Guo, J. Heeres and J. Yue, *Chem. Eng. J.*, 2020, **381**, 122754; (d) T. Tongtummachat, N. Akkarawatkhosith, A. Kaewchada and A. Jaree, *Front. Chem.*, 2020, **7**, 951; (e) S. Nishimura, A. Shibata and K. Ebitani, *ACS Omega*, 2018, **3**, 5988; (f) L. Atanda, A. Shrotri, S. Mukundan, Q. Ma, M. Konarova and J. Beltramini, *ChemSusChem*, 2015, **8**, 2907; (g) R. Galaverna, R. L. Ribessi, J. J. R. Rohwedder and J. C. Pastre, *Org. Process Res. Dev.*, 2018, **22**, 780.
- 49 (a) C. Aellig, D. Scholz, P. Y. Dapsens, C. Mondelli and J. Pérez-Ramírez, *Catal. Sci. Technol.*, 2015, **5**, 142; (b) C. Moreno-Marrodan, P. Barbaro, S. Caporali and F. Bossola, *ChemSusChem*, 2018, **11**, 3649; (c) A. D. Pérez, S. Rodríguez-Barona and J. Fontalvo, *Chem. Eng. Process.*, 2019, **140**, 85.
- 50 (a) E. Ohleyer, C. R. Wilke and H. W. Blanch, *Appl. Biochem. Biotechnol.*, 1985, **11**, 457; (b) A. B. F. Moreira, A. M. Bruno, M. M. V. M. Souza and R. L. Manfro, *Fuel Process. Technol.*, 2016, **144**, 170; (c) D. Motta, F. J. S. Trujillo, N. Dimitratos, A. Villa and L. Prati, *Catal. Today*, 2018, **308**, 50; (d) A. D. Pérez, S. Rodríguez-Barona and J. Fontalvo, *Chem. Eng. Process.*, 2019, **140**, 85; (e) M. Tao, Y. Li, X. Zhang, Z. Li, C. L. Hill and X. Wang, *ChemSusChem*, 2019, **12**, 2550.
- 51 (a) J. M. Tukacs, R. V. Jones, F. Darvas, G. Dibó, G. Lezsák and L. T. Mika, *RSC Adv.*, 2013, **37**, 16283; (b) K. Hengst, D. A. J. M. Ligthart, D. E. Doronkin, K. M. Walter, W. Kleist, E. J. M. Hensen and J.-D. Grunwaldt, *Ind. Eng. Chem. Res.*, 2017, **56**, 2680; (c) D. Zhao, Y. Wang, F. Delbecq and C. Len, *Mol. Catal.*, 2019, **475**, 110456; (d) K. Tadele, S. Verma, M. A. Gonzalez and R. S. Varma, *Green Chem.*, 2017, **19**, 1624; (e) J. Wang, S. Jaenicke and G.-K. Chuah, *RSC Adv.*, 2014, **4**, 13481.
- 52 M. D. Marquez-Medina, P. Prinsen, H. Li, K. Shih, A. A. Romero and R. Luque, *ChemSusChem*, 2018, **11**, 389.
- 53 (a) R. Gérardy, M. Winter, C. R. Horn, A. Vizza, K. Van Hecke and J.-C. M. Monbaliu, *Org. Process Res. Dev.*, 2017, **21**, 2012; (b) D. W. Hwang, P. Kashinathan, J. M. Lee, J. H. Lee, U.-H. Lee, J.-S. Hwang, Y. K. Hwang and J.-S. Chang, *Green Chem.*, 2011, **13**, 1672.
- 54 (a) R. Latsuzbaia, R. Bisselink, A. Anastasopol, H. van der Meer, R. van Heck, M. S. Yagüe, M. Zijlstra, M. Roelands, M. Crockatt, E. Goetheer and E. Giling, *J. Appl. Electrochem.*, 2018, **48**, 611; (b) F. Liguori, P. Barbaro and N. Calisi, *ChemSusChem*, 2019, **12**, 2558; (c) S. Cattaneo, D. Bonincontro, T. Bere, C. J. Kiely, G. J. Hutchings, N. Dimitratos and S. Albonetti, *ChemNanoMat*, 2020, **6**, 420.
- 55 S. Illner, C. Hofmann, P. Löb and U. Kragl, *ChemCatChem*, 2014, **6**, 1748.
- 56 C. Aellig, D. Scholz, S. Conrad and I. Hermans, *Green Chem.*, 2013, **15**, 1975.
- 57 H. Werhan, N. Assmann and P. Rudolf von Rohr, *Chem. Eng. Process.*, 2013, **73**, 29.
- 58 B. N. Zope and R. J. Davis, *Top. Catal.*, 2009, **52**, 269.
- 59 C. Eisenbeis, R. Guettel, U. Kunz and T. Turek, *Catal. Today*, 2009, **147**, S342.
- 60 A. Müller, G. Hilpmann, S. Haase and R. Lange, *Chem. Eng. Technol.*, 2017, **40**, 2113.
- 61 N. Joshi and A. Lawal, *Ind. Eng. Chem. Res.*, 2013, **52**, 4049.
- 62 (a) X. Sheng, N. Li, G. Li, W. Wang, A. Wang, Y. Cong, X. Wang and T. Zhang, *ChemSusChem*, 2017, **10**, 825; (b) G. W. Huber, J. N. Chheda, C. J. Barrett and J. A. Dumesic, *Science*, 2005, **308**, 1446; (c) M. Z. Hossain, M. B. I. Chowdhury, A. K. Jhavar, W. Z. Xu and P. A. Charpentier, *Fuel*, 2018, **212**, 470; (d) S. Qiu, T. Wang and Y. Fang, *Fuel Process. Technol.*, 2019, **183**, 19; (e) N. Li, G. A. Tompsett and G. W. Huber, *ChemSusChem*, 2010, **3**, 1154; (f) Y. Weng, S. Qiu, C. Wang, L. Chen, Z. Yuan, M. Ding, Q. Zhang, L. Ma and T. Wang, *Fuel*, 2016, **170**, 77.
- 63 R. Huang, Q. Cui, Q. Yuan, H. Wu, Y. Guan and P. Wu, *ACS Sustainable Chem. Eng.*, 2018, **6**, 6957.

- 64 O. Sato, A. Yamaguchi and M. Shirai, *Catal. Commun.*, 2015, **68**, 6.
- 65 (a) J. G. Stevens, R. A. Bourne, M. V. Twigg and M. Poliakoff, *Angew. Chem., Int. Ed.*, 2010, **49**, 8856; (b) P. P. Upare, J.-M. Lee, Y. K. Hwang, D. W. Hwang, J.-H. Lee, S. B. Halligudi, J.-S. Hwang and J.-S. Chang, *ChemSusChem*, 2011, **4**, 1749.
- 66 (a) Y.-T. Cheng and G. W. Huber, *Green Chem.*, 2012, **14**, 3114; (b) Y. Zhao, T. Pan, Y. Zuo, Q.-X. Guo and Y. Fu, *Bioresour. Technol.*, 2013, **147**, 37; (c) S. Tamiyakul, W. Ubolcharoen, D. N. Tungasmita and S. Jongpatiwut, *Catal. Today*, 2015, **256**, 325; (d) Z. Luo, S. Qin, S. Chen, Y. Hui and C. Zhao, *Green Chem.*, 2020, **22**, 1842.
- 67 (a) M. O. Guerrero-Pérez and M. A. Bañares, *ChemSusChem*, 2008, **1**, 511; (b) C. Liebig, S. Paul, B. Katryniok, C. Guillon, J.-L. Couturier, J.-L. Dubois, F. Dumeignil and W. F. Hoelderich, *Appl. Catal., B*, 2013, **132–133**, 170; (c) R. Liu, T. Wang, D. Cai and Y. Jin, *Ind. Eng. Chem. Res.*, 2014, **53**, 8667; (d) L. Ott, M. Bicker and H. Vogel, *Green Chem.*, 2006, **8**, 214; (e) V. Lehr, M. Sarlea, L. Ott and H. Vogel, *Catal. Today*, 2007, **121**, 121; (f) M. Watanabe, T. Iida, Y. Aizawa, T. M. Aida and H. Inomata, *Bioresour. Technol.*, 2007, **98**, 1285; (g) L. Cheng, L. Liu and X. P. Ye, *J. Am. Oil Chem. Soc.*, 2013, **90**, 601; (h) J. Peng, X. Li, C. Tang and W. Bai, *Green Chem.*, 2014, **16**, 108; (i) X. Li, Z. Chen, P. Cao, W. Pu, W. Zou, C. Tang and L. Dong, *RSC Adv.*, 2017, **7**, 54696.
- 68 (a) X. Li, J. Ko and Y. Zhan, *ChemSusChem*, 2017, **11**, 612; (b) G. Pavarelli, J. Velasquez Ochoa, A. Caldarelli, F. Puzzo, F. Cavani and J.-L. Dubois, *ChemSusChem*, 2015, **8**, 2250.
- 69 (a) J. Xia, D. Yu, Y. Hu, B. Zou, P. Sun, H. Li and H. Huang, *Catal. Commun.*, 2011, **12**, 544; (b) S. Zhu, X. Gao, Y. Zhu and Y. Li, *J. Mol. Catal. A: Chem.*, 2015, **398**, 391; (c) M. Li, G. Li, N. Li, A. Wang, W. Dong, X. Wang and Y. Cong, *Chem. Commun.*, 2014, **50**, 1414; (d) B. Xiao, M. Zheng, X. Li, J. Pang, R. Sun, H. Wang, X. Pang, A. Wang, X. Wang and T. Zhang, *Green Chem.*, 2016, **18**, 2175; (e) D. Sun, Y. Yamada, S. Sato and W. Ueda, *Appl. Catal., B*, 2016, **193**, 75; (f) D. R. Vardon, A. E. Settle, V. Vorotnikov, M. J. Menart, T. R. Eaton, K. A. Unocic, K. X. Steirer, K. N. Wood, N. S. Cleveland and K. E. Moyer, *ACS Catal.*, 2017, **7**, 6207.
- 70 (a) P. P. Upare, J. W. Yoon and D. W. Hwang, *et al.*, *Green Chem.*, 2016, **18**, 5978; (b) R. De Clercq, M. Dusselier, E. Makshina and B. F. Sels, *Angew. Chem., Int. Ed.*, 2018, **57**, 3074; (c) R. De Clercq, M. Dusselier, C. Poleunis, D. P. Debecker, L. Giebeler, S. Oswald, E. Makshina and B. F. Sels, *ACS Catal.*, 2018, **8**, 8130.
- 71 (a) C. W. Luo, C. Huang, A. Li, W.-J. Yi, X.-Y. Feng, Z.-J. Xu and Z.-S. Chao, *Ind. Eng. Chem. Res.*, 2016, **55**, 893; (b) A. Li, C. Huang, C.-W. Luo, W.-J. Yi and Z.-S. Chao, *RSC Adv.*, 2017, **7**, 9551; (c) Q. Yao, L. Xu, Y. Zhang and Y. Fu, *J. Anal. Appl. Pyrolysis*, 2016, **121**, 258; (d) A. Venugopal, R. Sarkari, C. Anjaneyulu, V. Krishna, M. K. Kumar, N. Narender and A. H. Padmasri, *Appl. Catal., A*, 2014, **469**, 398; (e) C. Huang, A. Li and Z.-S. Chao, *RSC Adv.*, 2017, **7**, 48275; (f) J. Hou, W. Luo, S. Luo, C. Lin, P. Liu, X. Liao, F. Jing and X. Li, *RSC Adv.*, 2017, **7**, 48662; (g) V. Krishna, S. N. Kumar, S. Reema, A. H. Padmasri, K. V. R. Chary and A. Venugopal, *Appl. Catal., A*, 2014, **488**, 275.
- 72 (a) S. Guidi, M. Noè, P. Riello, A. Perosa and M. Selva, *Molecules*, 2016, **21**, 657; (b) J. C. M. Monbaliu, M. Winter, B. Chevalier, F. Schmidt, Y. Jiang, R. Hoogendoorn, M. A. Kousemaker and C. V. Stevens, *Bioresour. Technol.*, 2011, **102**, 9304; (c) A. Cornejo, M. Campoy, I. Barrio, B. Navarrete and J. Lázaro, *React. Chem. Eng.*, 2019, **4**, 1803; (d) P. A. Oliveira, R. O. M. A. Souza and C. J. A. Mota, *J. Braz. Chem. Soc.*, 2016, **27**, 1832.
- 73 D. Dakshinamoorthy, S. P. Lewis, M. P. Cavazza, A. M. Hoover, D. F. Iwig, K. Damodaran and R. T. Mathers, *Green Chem.*, 2014, **16**, 1774.
- 74 (a) F. Dong, Y. Zhu, H. Zheng, Y. Zhu, X. Li and Y. Li, *J. Mol. Catal. A: Chem.*, 2015, **398**, 140; (b) Y. Román-Leshkov, C. J. Barrett, Z. Y. Liu and J. A. Dumesic, *Nature*, 2007, **447**, 982; (c) W. Li, G. Fan, L. Yang and F. Li, *Green Chem.*, 2017, **19**, 4353; (d) D. Scholz, C. Aellig and I. Hermans, *ChemSusChem*, 2014, **7**, 268; (e) C. Aellig, F. Jenny, D. Scholz, P. Wolf, I. Giovinazzo, F. Kollhoff and I. Hermans, *Catal. Sci. Technol.*, 2014, **4**, 2326; (f) K. Xiong, W.-S. Lee, A. Bhan and J. G. Chen, *ChemSusChem*, 2014, **7**, 2146; (g) C. P. Jiménez-Gómez, J. A. Cecilia, C. García-Sancho, R. Moreno-Tost and P. Maireles-Torres, *ACS Sustainable Chem. Eng.*, 2019, **7**, 7676; (h) A. Guerrero-Torres, C. P. Jiménez-Gómez, J. A. Cecilia, C. García-Sancho, F. Franco, J. J. Quirante-Sánchez and P. Maireles-Torres, *Top. Catal.*, 2019, **62**, 535; (i) C. Wang, Z. Liu, L. Wang, X. Dong, J. Zhang, G. Wang, S. Han, X. Meng, A. Zheng and F. S. Xiao, *ACS Catal.*, 2018, **8**, 474.
- 75 (a) S. Guidi, R. Calmanti, M. Noè, A. Perosa and M. Selva, *ACS Sustainable Chem. Eng.*, 2016, **4**, 6144; (b) Z. Wang, R. Gérardy, G. Gauron, C. Damblon and J.-C. M. Monbaliu, *React. Chem. Eng.*, 2019, **4**, 17; (c) R. Gérardy, J. Estager, P. Luis, D. P. Debecker and J.-C. M. Monbaliu, *Catal. Sci. Technol.*, 2019, **9**, 6841; (d) S. Van Mileghem, W. M. De Borggraeve and I. R. Baxendale, *Chem. Eng. Technol.*, 2018, **41**, 2014.
- 76 J. Shen, W. Shan, Y. Zhang, J. Du, H. Xu, K. Fan, W. Shen and Y. Tang, *Chem. Commun.*, 2004, 2880.
- 77 M. N. Zharkov, S. S. Arabadzhi, I. V. Kuchurov and S. G. Zlotin, *React. Chem. Eng.*, 2019, **4**, 1303.
- 78 G. M. Lari, C. Mondelli and J. Pérez-Ramírez, *ACS Catal.*, 2015, **5**, 1453.
- 79 (a) M. Velasquez, A. Santamaria and C. Batiot-Dupeyrat, *Appl. Catal., B*, 2014, **160–161**, 606; (b) D. Hernandez, M. Velasquez, P. Ayrault, D. Lopez, J. J. Fernandez, A. Santamaria and C. Batiot-Dupeyrat, *Appl. Catal., A*, 2013, **467**, 315; (c) Y. Feng, H. Yin, L. Shen, A. Wang, Y. Shen and T. Jiang, *Chem. Eng. Technol.*, 2013, **36**, 73.
- 80 (a) Z. Wu, K. Zhao, S. Ge, Z. Qiao, J. Gao, T. Dou, A. C. K. Yip and M. Zhang, *ACS Sustainable Chem. Eng.*, 2016, **4**, 4192; (b) Z. Wu, H. Yan, S. Ge, J. Gao, T. Dou, Y. Li, A. C. K. Yip and M. Zhang, *Catal. Commun.*, 2017, **92**, 80.
- 81 R. Morodo, R. Gérardy, G. Petit and J.-C. M. Monbaliu, *Green Chem.*, 2019, **21**, 4422.
- 82 (a) M. Audemar, Y. Wang, D. Zhao, S. Royer, F. Jérôme, C. Len and K. De Oliveira Vigier, *Energies*, 2020, **13**, 1002; (b) C. P.

- Jiménez-Gómez, C. Defilippi, J. A. Cecilia, R. Moreno-Tost, P. Maireles-Torres and C. Giordano, *Mol. Catal.*, 2020, **487**, 110889; (c) S. A. Selishcheva, A. A. Smirnov, A. V. Fedorov, O. A. Bulavchenko, A. A. Saraev, M. Y. Lebedev and V. A. Yakovlev, *Catalysts*, 2019, **9**, 816; (d) M. Ghashghaee, S. Sadjadi, S. Shirvani and V. Farzaneh, *Catal. Lett.*, 2017, **147**, 318.
- 83 X. Li, L. Sun, W. Zou, P. Cao, Z. Chen, C. Tang and L. Dong, *ChemCatChem*, 2017, **9**, 4621.
- 84 X. Li, Z. Zhai, C. Tang, L. Sun, Y. Zhang and W. Bai, *RSC Adv.*, 2016, **6**, 62252.
- 85 D. Mack, S. Schätzle, Y. Traa and E. Klemm, *ChemSusChem*, 2019, **12**, 1653.
- 86 X. Kong, S. Wu, L. Liu, S. Li and J. Liu, *Mol. Catal.*, 2017, **439**, 180.
- 87 (a) T. Peschke, P. Bitterwolf, S. Gallus, Y. Hu, C. Oelschlaeger, N. Willenbacher, K. S. Rabe and C. M. Niemeyer, *Angew. Chem., Int. Ed.*, 2018, **57**, 17028; (b) C. J. Hartley, C. C. Williams, J. A. Scoble, Q. I. Churches, A. North, N. G. French, T. Nebl, G. Coia, A. C. Warden and G. Simpson, *et al.*, *Nat. Catal.*, 2019, **2**, 1006.
- 88 (a) L. Tamborini, P. Fernandes, F. Paradisi and F. Molinari, *Trends Biotechnol.*, 2018, **36**, 73; (b) M. Planchestainer, M. L. Contente, J. Cassidy, F. Molinari, L. Tamborini and F. Paradisi, *Green Chem.*, 2017, **19**, 372; (c) M. L. Contente, F. Dall'Oglio, L. Tamborini, F. Molinari and F. Paradisi, *ChemCatChem*, 2017, **9**, 3843; (d) D. Roura Padrosa, A. I. Benítez-Mateos, L. Calvey and F. Paradisi, *Green Chem.*, 2020, **22**, 5310; (e) V. De Vitis, F. Dall'Oglio, A. Pinto, C. De Micheli, F. Molinari, P. Conti, D. Romano and L. Tamborini, *ChemistryOpen*, 2017, **6**, 668; (f) M. L. Contente, S. Farris, L. Tamborini, F. Molinari and F. Paradisi, *Green Chem.*, 2019, **21**, 3263.
- 89 (a) M. Romero-Fernández and F. Paradisi, *Curr. Opin. Chem. Biol.*, 2020, **55**, 1; (b) M. T. De Martino, F. Tonin, N. A. Yewdall, M. Abdelghani, D. S. Williams, U. Hanefeld, F. P. J. T. Rutjes, L. K. E. A. Abdelmohsen and J. C. M. Van Hest, *Chem. Sci.*, 2020, **11**, 2765.
- 90 D. Weiser, F. Nagy, G. Bánóczy, M. Oláh, A. Farkas, A. Szilágyi, K. László, A. Gellért, G. Marosi and S. Kemény, *et al.*, *Green Chem.*, 2017, **19**, 3927.
- 91 J. Britton, R. P. Dyer, S. Majumdar, C. L. Raston and G. A. Weiss, *Angew. Chem., Int. Ed.*, 2017, **56**, 2296.
- 92 S. Velasco-Lozano, A. I. Benítez-Mateos and F. López-Gallego, *Angew. Chem., Int. Ed.*, 2017, **56**, 771.
- 93 B. Wenn and T. Junkers, *Macromolecules*, 2016, **49**, 6888.
- 94 B. L. Buss, C. H. Lim and G. M. Miyake, *Angew. Chem., Int. Ed.*, 2020, **59**, 3209.
- 95 S. A. Van Den Berg, H. Zuilhof and T. Wennekes, *Macromolecules*, 2016, **49**, 2054.
- 96 J. Morsbach, A. H. E. Müller, E. Berger-Nicoletti and H. Frey, *Macromolecules*, 2016, **49**, 5043.
- 97 (a) M. H. Reis, F. A. Leibfarth and L. M. Pitet, *ACS Macro Lett.*, 2020, **9**, 123; (b) W. Xu, Y. Su, M. Shang, X. Lu and Q. Lu, *Chem. Eng. J.*, 2020, **397**, 125361; (c) J. Ilare, M. Sponchioni, G. Storti and D. Moscatelli, *React. Chem. Eng.*, 2020, **5**, 2081.
- 98 B. Lin, J. L. Hedrick, N. H. Park and R. M. Waymouth, *J. Am. Chem. Soc.*, 2019, **141**, 892.
- 99 M. Rubens, J. H. Vrijssen, J. Laun and T. Junkers, *Angew. Chem., Int. Ed.*, 2019, **58**, 3183.
- 100 M. H. Reis, T. P. Varner and F. A. Leibfarth, *Macromolecules*, 2019, **52**, 3551.
- 101 (a) O. Levelspiel, *The Chemical Reactor Omnibook*, OSU Book Stores, Inc., Corvallis, Oregon, 1993; (b) O. Levenspiel, *Chemical Reaction Engineering. An Introduction to the Design of Chemical Reactors*, John Wiley and Sons, Inc., New York, NY, 1962; (c) R. Aris, *Proc. R. Soc. London, Ser. A*, 1956, **235**, 67; (d) G. Taylor, *Proc. R. Soc. London, Ser. A*, 1953, **219**, 186; (e) G. Taylor, *Proc. R. Soc. London, Ser. A*, 1954, **223**, 446; G. Taylor, *Proc. R. Soc. London, Ser. A*, 1954, **223**, 473; (f) K. D. Nagy, B. Shen, T. F. Jamison and K. F. Jensen, *Org. Process Res. Dev.*, 2012, **16**, 976.
- 102 E. J. Roberts, L. R. Karadaghi, L. Wang, N. Malmstadt and R. L. Brutchey, *ACS Appl. Mater. Interfaces*, 2019, **11**, 27479.
- 103 J. Mahin and L. Torrente-Murciano, *Chem. Eng. J.*, 2020, **396**, 125299.
- 104 (a) A. P. LaGrow, T. M. D. Besong, N. M. AlYami, K. Katsiev, D. H. Anjum, A. Abdelkader, P. M. F. J. Costa, V. M. Burlakov, A. Goriely and O. M. Bakr, *Chem. Commun.*, 2017, **53**, 2495; (b) R. M. Myers, D. E. Fitzpatrick, R. M. Turner and S. V. Ley, *Chem. – Eur. J.*, 2014, **20**, 12348; (c) J. B. Edel, R. Fortt, J. C. deMello and A. J. deMello, *Chem. Commun.*, 2002, 1136; (d) Y. Schaerli, R. C. Wootton, T. Robinson, V. Stein, C. Dunsby, M. A. A. Neil, P. M. W. French, A. J. deMello, C. Abell and F. Hollfelder, *Anal. Chem.*, 2009, **81**, 302.
- 105 I. Lignos, S. Stavrakis, G. Nedelcu, L. Protesescu, A. J. deMello and M. V. Kovalenko, *Nano Lett.*, 2016, **16**, 1869.
- 106 W. Zhenlei, F. Hongsheng, L. Hongxia, M. Jugang, L. Shuai, S. Yujun and W. Rongming, *Electrochim. Acta*, 2017, **230**, 245.
- 107 H. Tsunoyama, N. Ichikuni and T. Tsukuda, *Langmuir*, 2008, **24**, 11327.
- 108 F. G. Baddour, E. J. Roberts, A. T. To, L. Wang, S. E. Habas, D. A. Ruddy, N. M. Bedford, J. Wright, C. P. Nash and J. A. Schaidle, *et al.*, *J. Am. Chem. Soc.*, 2020, **142**, 1010.
- 109 K. Loizou, S. Mourdikoudis, A. Sergides, M. O. Besenhard, C. Sarafidis, K. Higashimine, O. Kalogirou, S. Maenosono, N. T. K. Thanh and A. Gavriilidis, *ACS Appl. Mater. Interfaces*, 2020, **12**, 28520.
- 110 S. Kim, H. Wang, L. Yan, X. Zhang and Y. Cheng, *Chem. Eng. J.*, 2020, **393**, 124721.
- 111 (a) D. Albani, G. Vilé, M. A. B. Toro, R. Kaufmann, S. Mitchell and J. Pérez-Ramírez, *React. Chem. Eng.*, 2016, **1**, 454; (b) O. Okafor, A. Weillhard, J. A. Fernandes, E. Karjalainen, R. Goodridge and V. Sans, *React. Chem. Eng.*, 2017, **2**, 129; (c) C. Li, B. Ding, L. Zhang, K. Song and S. Tao, *J. Mater. Chem. C*, 2019, **7**, 9167; (d) J. Latocha, M. Wojasiński, K. Jurczak, S. Gierlotka, P. Sobieszuk and T. Ciach, *Chem. Eng. Process.*, 2018, **133**, 221.
- 112 G. Vilé, G. Schmidt, S. Richard-Bildstein and S. Abele, *J. Flow Chem.*, 2019, **9**, 19.

- 113 M. Colella, A. Tota, Y. Takahashi, R. Higuma, S. Ishikawa, L. Degennaro, R. Luisi and A. Nagaki, *Angew. Chem., Int. Ed.*, 2020, **59**, 10924.
- 114 H. Usutani, T. Nihei, C. D. Papageorgiou and D. G. Cork, *Org. Process Res. Dev.*, 2017, **21**, 669.
- 115 H. Yasukouchi, A. Nishiyama and M. Mitsuda, *Org. Process Res. Dev.*, 2018, **22**, 247.
- 116 (a) G. Vilé, D. Albani, M. Nachtegaal, Z. Chen, D. Dontsova, M. Antonietti, N. López and J. A. Pérez-Ramírez, *Angew. Chem., Int. Ed.*, 2015, **54**, 11265; (b) G. Vilé, D. Albani, N. Almora-Barrios, N. López and J. Pérez-Ramírez, *ChemCatChem*, 2016, **8**, 21; (c) G. Vilé, N. Almora-Barrios, S. Mitchell, N. López and J. Pérez-Ramírez, *Chem. – Eur. J.*, 2014, **20**, 5926.
- 117 (a) A. Harsanyi, A. Conte, L. Pichon, A. Rabion, S. Grenier and G. Sandford, *Org. Process Res. Dev.*, 2017, **21**, 273; (b) D. Cantillo, O. de Frutos, J. A. Rincón, C. Mateos and C. O. Kappe, *J. Org. Chem.*, 2014, **79**, 8486.
- 118 Y. Chen, C. A. Hone, B. Gutmann and C. O. Kappe, *Org. Process Res. Dev.*, 2017, **21**, 1080.
- 119 (a) A. G. O'Brien, F. Lévesque and P. H. Seeberger, *Chem. Commun.*, 2011, **47**, 2688; (b) S. Tortoioli, A. Friedli, A. Prud'homme, S. Richard-Bildstein, P. Kohler, S. Abele and G. Vilé, *Green Chem.*, 2020, **22**, 3748.
- 120 A. R. Bogdan and N. W. Sach, *Adv. Synth. Catal.*, 2009, **351**, 849.
- 121 J. L. Monteiro, B. Pieber, A. G. Corrêa and C. O. Kappe, *Synlett*, 2015, **26**, 83.
- 122 (a) M. O'Brien, I. R. Baxendale and S. V. Ley, *Org. Lett.*, 2010, **12**, 1596; (b) L. Yang and K. F. Jensen, *Org. Process Res. Dev.*, 2013, **17**, 927; (c) J. C. Pastre, D. L. Browne, M. O'Brien and S. V. Ley, *Org. Process Res. Dev.*, 2013, **17**, 1183.
- 123 F. Mastronardi, B. Gutmann and C. O. Kappe, *Org. Lett.*, 2013, **15**, 5590.
- 124 M. Brzozowski, M. O'Brien, S. V. Ley and A. Polyzos, *Acc. Chem. Res.*, 2015, **48**, 349.
- 125 A. J. Blacker and K. E. Jolley, *Beilstein J. Org. Chem.*, 2015, **11**, 2408.
- 126 P. Murray, D. L. Browne, J. C. Pastre, C. Butters, D. Guthrie and S. V. Ley, *Org. Process Res. Dev.*, 2013, **17**, 1192.
- 127 Z. He, M. Bae, J. Wu and T. F. Jamison, *Angew. Chem., Int. Ed.*, 2014, **53**, 14451.
- 128 (a) Z. Chen, E. Vorobyeva, S. Mitchell, E. Fako, M. A. Ortuño, N. López, S. M. Collins, P. A. Midgley, S. Richard and G. Vilé, *et al.*, *Nat. Nanotechnol.*, 2018, **13**, 702; (b) G. Vilé, S. Richard-Bildstein, A. Lhuillery and G. Rueedi, *ChemCatChem*, 2018, **10**, 3786.
- 129 (a) B. Gutmann, M. Köckinger, G. Glotz, T. Ciaglia, E. Slama, M. Zdravec, S. Pfanner, M. C. Maier, H. Gruber-Wölfler and C. O. Kappe, *React. Chem. Eng.*, 2017, **2**, 919; (b) A. Beltagui, A. Rosli and M. Candi, *Resour. Policy*, 2020, **49**, 1038332.
- 130 M. C. Maier, R. Lebl, P. Sulzer, J. Lechner, T. Mayr, M. Zdravec, E. Slama, S. Pfanner, C. Schmölzer, P. Pöchlauer, C. O. Kappe and H. Gruber-Woelfler, *React. Chem. Eng.*, 2019, **4**, 393.
- 131 S. Rossi, R. Porta, D. Brenna, A. Puglisi and M. Benaglia, *Angew. Chem., Int. Ed.*, 2017, **56**, 4290.
- 132 J. M. Neumaier, A. Madani, T. Klein and T. Ziegler, *Beilstein J. Org. Chem.*, 2019, **15**, 558.
- 133 M. Peng, E. Mittmann, L. Wenger, J. Hubbuch, M. K. M. Engqvist, C. M. Niemeyer and K. S. Rabe, *Chem. – Eur. J.*, 2019, **25**, 15998.
- 134 A. Amor-Coarasa, J. M. Kelly and J. W. Babich, *Sci. Adv.*, 2019, **5**, 4762.
- 135 F. Menzel, T. Klein, T. Ziegler and J. M. Neumaier, *React. Chem. Eng.*, 2020, **5**, 1300.
- 136 Z. X. Rao, B. Patel, A. Monaco, Z. J. Cao, M. Barniol-Xicota, E. Pichon, M. Ladlow and S. T. Hilton, *Eur. J. Org. Chem.*, 2017, 6499.
- 137 D. Hur, M. G. Say, S. E. Diltemiz, F. Duman, A. Ersöz and R. Say, *ChemPlusChem*, 2018, **83**, 42.
- 138 (a) G. Schneider, *Nat. Rev. Drug Discovery*, 2018, **17**, 97; (b) C. Réda, E. Kaufmann and A. Delahaye-Duriez, *Comput. Struct. Biotechnol. J.*, 2020, **18**, 241; (c) B. J. Reizman and K. F. Jensen, *Org. Process Res. Dev.*, 2012, **16**, 1770; (d) Novartis, *Robots speed pace modern drug discovery*, Available at: <https://www.novartis.com/stories/from-our-labs/robots-speed-pace-modern-drug-discovery>, (Accessed on March 2020).
- 139 S. Steiner, J. Wolf, S. Glatzel, A. Andreou, M. Granda, G. Keenan, T. Hinkley, G. Aragon-Camarasa, P. J. Kitson and D. Angelone, *et al.*, *Science*, 2019, 363.
- 140 D. Caramelli, D. Salley, G. Keenan, L. Cronin, A. Henson and G. A. Camarasa, *Nat. Commun.*, 2018, **9**, 1.
- 141 S. Chatterjee, M. Guidi, P. H. Seeberger and K. Gilmore, *Nature*, 2020, **579**, 379.
- 142 C. W. Coley, D. A. Thomas, J. A. M. Lummiss, J. N. Jaworski, C. P. Breen, V. Schultz, T. Hart, J. S. Fishman, L. Rogers, H. Gao, R. W. Hicklin, P. P. Plehiers, J. Byington, J. S. Piotti, W. H. Green, A. J. Hart, T. F. Jamison and K. F. Jensen, *Science*, 2019, **365**, 1566.
- 143 D. Lowe, *Chemical reactions from US patents (1976-Sep2016)*, 2017, DOI: 10.6084/m9.figshare.5104873.v1.
- 144 D. E. Fitzpatrick, T. Maujean, A. C. Evans and S. V. Ley, *Angew. Chem., Int. Ed.*, 2018, **57**, 15128.
- 145 (a) S. D. Axen, X.-P. Huang, E. L. Cáceres, L. Gendeleev, B. L. Roth and M. J. A. Keiser, *J. Med. Chem.*, 2017, **60**, 7393; (b) J. Verma, V. M. Khedkar and E. C. Coutinho, *Curr. Top. Med. Chem.*, 2010, **10**, 95.
- 146 S. D. Axen, X.-P. Huang, E. L. Cáceres, L. Gendeleev, B. L. Roth and M. J. Keiser, *J. Med. Chem.*, 2017, **60**, 7393.
- 147 (a) Y. Cao, B. Adriaenssens, A. de Bartolomeu, G. Laudadio, K. T. de Oliveira and T. Noël, *J. Flow Chem.*, 2020, **10**, 191; (b) G. Laudadio, Y. Deng, K. van der Wal, D. Ravelli, M. Nuño, M. Fagnoni, D. Guthrie, Y. Sun and T. Noël, *Science*, 2020, **369**, 92; (c) Z. Wen, A. Maheshwari, C. Sambiagio, Y. Deng, G. Laudadio, K. Van Aken, Y. Sun, H. P. L. Gemoets and T. Noël, *Org. Process Res. Dev.*, 2020, **24**, 2356; (d) T. Noël, Y. Cao and G. Laudadio, *Acc. Chem. Res.*, 2019, **52**, 2858; (e) D. Cambié, C. Bottecchia, N. J. W. Straathof, V. Hessel and T. Noël, *Chem. Rev.*, 2016, **116**, 10276; (f) Y. Su, N. J. W. Straathof, V. Hessel and T. Noël, *Chem. – Eur. J.*, 2014, **20**, 10562.