

FE PUSHOVER ANALYSES OF A 20TH-CENTURY MASONRY CHIMNEY IN SPAIN: COLLAPSE BEHAVIOUR AND NUMERICAL UNCERTAINTIES

Alessandro De Iasio¹, Gabriele Milani² and Jose M Adam³

¹ University of Nottingham, Faculty of Engineering, Centre for Structural Engineering and Informatics
University Park, Nottingham, United Kingdom
alessandro.deiasio@nottingham.ac.uk

² Politecnico di Milano
Department of Architecture Built Environment and Construction Engineering ABC, Piazza Leonardo
da Vinci, 32, 20144, Milan, Italy
gabriele.milani@polimi.it

³ ICITECH, Universitat Politècnica de València, Camino de Vera s/n, 46022 Valencia, Spain
joadmar@upv.es

Abstract

The seismic vulnerability of masonry chimneys is a critical research topic, and it has an important role in the preservation of such kind of structural type. Indeed, masonry chimneys have a very high seismic vulnerability and are sometimes located in high seismic hazard zones. Researches about this topic have become even more frequent in the last decades. However, the results are still limited, and further studies are needed. This paper aims to study the seismic behaviour of a 20th-century masonry chimney located in Spain, focusing on its ultimate behaviour. In particular, various FE pushover analyses have been carried out in Abaqus/CAE using a quite accurate 3D model of the chimney. The pushover analyses have been made along the four principal directions, and both G1 and G2 load distributions have been applied. The material properties have been chosen according to previous studies carried out on similar structures because no specific experimental data were available. The obtained capacity curves have been compared with each other, and the main weak points of the chimney have been pointed out. Finally, a sensitivity analysis has been done to better understand the influence of the viscosity parameter on the pushover results in terms of ultimate capacity and computational effort. The latter one is an input value of the Concrete Damage Plasticity model, an Abaqus built-in material model, widely used to represent the non-linear behaviour of masonry structures.

Keywords: masonry chimneys; earthquake; pushover; Finite Element Method; CDP; viscosity parameter; computational effort

1 INTRODUCTION

The seismic vulnerability of masonry chimneys is a critical research topic, and it has an important role in the worldwide conservation of such kind of masonry structures. Indeed, masonry chimneys have a very high seismic vulnerability and are often located in high seismic hazard zones. Researches about this topic have become even more frequent in the last decades. However, the results about the seismic behaviour of the chimneys are still limited, and further research is needed.

Generally, masonry tower-like structures have usually shown high seismic vulnerability [1–6]; their seismic response is complex and depends on various parameters, both mechanical and geometrical. Different analysis methods have been usually applied. Non-linear static and dynamic analysis are the most used analysis tools, and they have been fully and successfully used in [1,2,7–10]. Also, simplified methods have been introduced, like the kinematic limit analysis has shown its accuracy and efficiency in various studies (e.g. in [11–14]). [15–17] have demonstrated the importance of the tower inclination in their seismic assessment, while the influence of the surrounding buildings has been studied in [18].

Chimneys are usually brickwork structures, and their typical high slenderness makes them very vulnerable when subjected to horizontal actions: it has been highlighted in [19] that such structures may be affected by several actions, and among them, earthquakes play a significant role. Therefore, their ductility against horizontal loads is crucial. Specific studies on these structures have been presented in [5,19–25].

This paper aims to study the ultimate behaviour of such structures by using some pushover analysis carried out with Abaqus/CAE and applied to a real case-study: a 20th-century masonry chimneys located in Villar del Arzobispo (Spain) (Figure 1). It is almost 28m high, and the base edge is 2.4m long. The base cross-section is a square and became octagonal after almost 5m from the ground. A small opening is present on one of the base facades, and it is directly connected with the flue, which runs from the base to the top of the chimney with the same shape as the exteriors. Figure 2 shows the 2D technical drawing of the chimney.



Figure 1: The chimney located in Villar del Arzobispo (Spain) used as a case-study of this research.

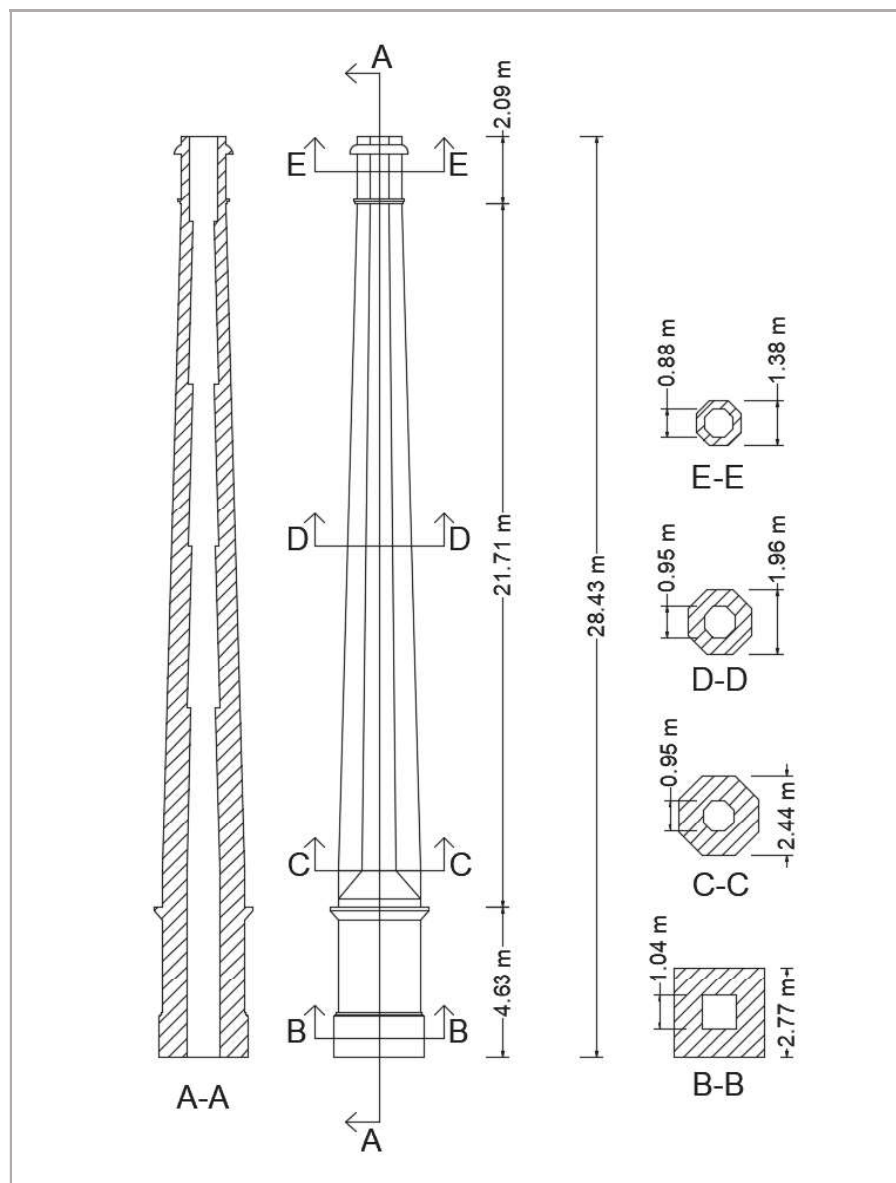

Figure 2: Technical drawing of the Villar del Arzobispo's chimney.

Different POs analyses have been produced, loading the chimney along the four principal directions and using both the G1 and G2 load distributions (Figure 3). The material properties have been chosen according to previous studies carried out on similar structures because no specific experimental data were available. The plastic properties have been considered through the Concrete Damage Plasticity (CDP) model, an Abaqus built-in material model, widely used to represent the non-linear behaviour of masonry structures. The results have been used to compare the capacity curves between each other and point out the chimney's main weak points. Finally, a sensitivity analysis has been done on the viscosity parameter. The latter one is a numerical input value of the CDP, and it helps the analysis's steps to converge by smoothing the yield surface. It has been often highlighted that the viscosity parameter increment tends to overestimate the ultimate capacity (e.g. in [26]). On the other hand, the decreasing of the viscosity parameter increase the computational effort; therefore, a sensitivity

analysis on this parameter may be helpful to better understand the influence of this parameter on the pushover results.

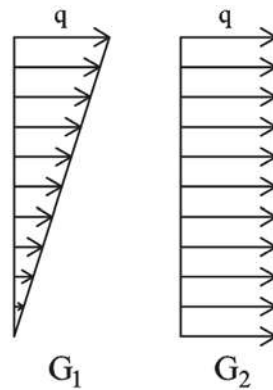

Figure 3: G1 and G2 load distributions.

The structure of this paper is as follow. Section 2 will briefly present the pushover results related to the analyses carried out on the four principal directions with fixed model properties, while, in Section 3, the influence of some numerical parameters has been presented. Discussions and conclusions are drawn in Section 4.

2 THE FE PUSHOVER RESULTS

The pushover analyses have been carried out on a 3D Finite Element model in Abaqus/CAE [27]. The FE model uses a 3D representation of the actual chimney geometry (Figure 4), which has been built in the Autodesk Inventor environment starting from the available 2D drawings.

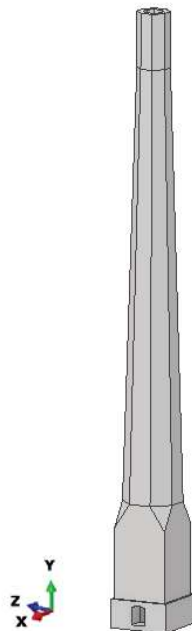

Figure 4: 3D model of the chimney case-study.

It has been decided to adopt a macro-modelling approach, and, in light of this latter choice, solid, homogeneous, and isotropic properties have been applied to the whole chimney body. The material properties have been chosen following the study presented in [20], and the main

mechanical parameters are shown in Table 1. The material non-linearities have been modelled employing the Concrete Damage Plasticity (CDP) model, whose main parameters are reported in Table 1 Main mechanical parameters.

. The compressive behaviour has been modelled by a brickwork feasible stress-strain relationship (Figure 5), while the fracture energy approach has been used for the tensile behaviour (Figure 6). The fracture energy has been computed by Eq. (1) as suggested in [28], and it is equal to 8.1 N/m.

$$G=0.025 (2\sigma_t)^{0.7} \quad (1)$$

Density ρ [kg/m ³]	Young's Modulus E [MPa]	Poisson's ratio ν [-]	σ_c [MPa]	σ_t [MPa]
1800	1500	0.15	3.5	0.1

Table 1 Main mechanical parameters.

Dilatation Angle	Eccentricity	f_{b0}/f_{c0}	K_c	Viscosity parameter
10°	0.1	1.16	0.667	0.0005

Table 2 Main parameters for the CDP

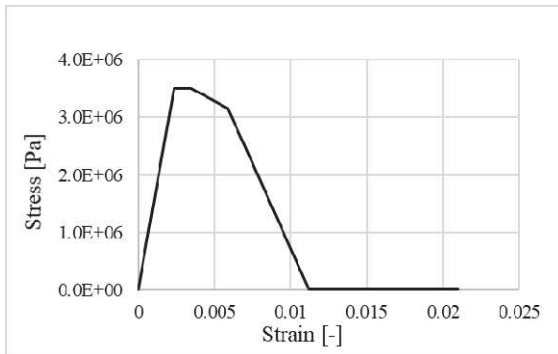

Figure 5: Compressive stress-strain branch to define the compressive CDP part in Abaqus.

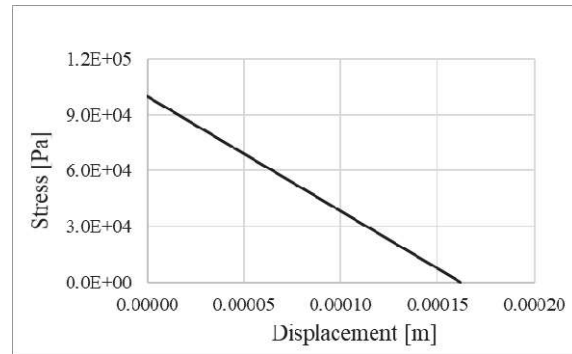

Figure 6: The post-failure tensile stress-fracture energy curve used to define the tensile CDP part in Abaqus.

The chimney body has been meshed through the Abaqus's automesh command. A seed dimension equal to 0.2m has been input, and linear tetrahedral elements of type C3D4 has been chosen. The model has a total number of 17289 nodes and 79666 elements. Figure 7 shows the meshed body, being possible to see that the discretisation is very refined. The element dimension may be considered adequate since the elements are linear.

The pushover analyses have been carried out along the four principal directions applying a G1 load distribution and along the z+ direction involving a G2 load distribution. The capacity curves have been built using the Load Factor (which is the ratio between the base shear and the total weight of the structure) and the horizontal displacement of a control point located at the top of the chimney. Both the letter quantities are related to the pushover direction. Furthermore, the tensile damage maps have been analysed.

Figure 8 shows the pushover analyses' capacity curves along the four principal directions using a G1 load distribution. It is worth noting that the four curves almost coincide; therefore, the singularities of the chimney body, i.e. the small opening at the base, doesn't play a crucial

role in the seismic response (differently from [26], in which it has been shown that the opening at the base of the case-study pagoda constitutes a weak point for the overall dynamic response). Figure 9, instead, presents a comparison between the G1 and the G2 loads' application along the $z+$ direction. As expected, the ultimate capacity in the latter case is higher.



Figure 7: The meshed model .with 3D elements

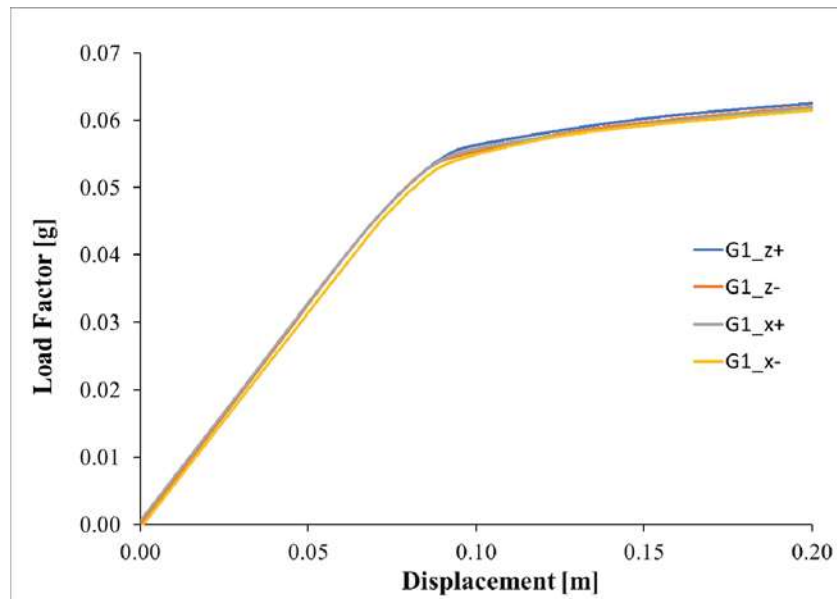

Figure 8: Capacity curves of the pushovers along the four principal directions.

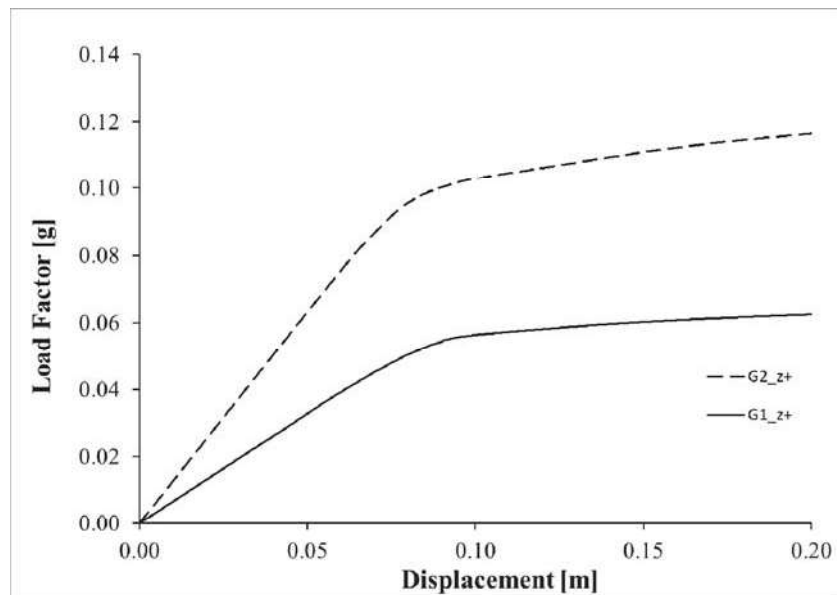
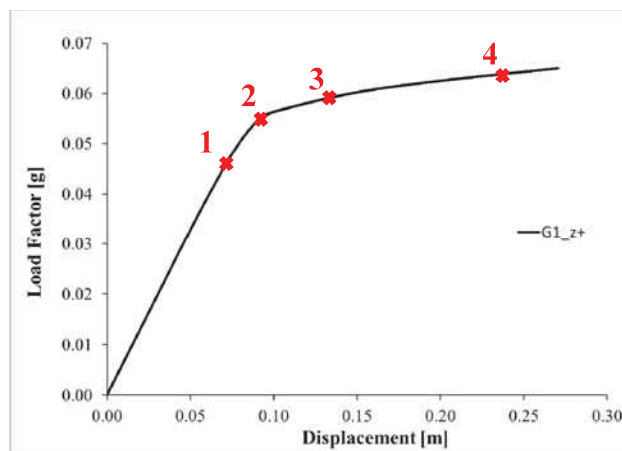
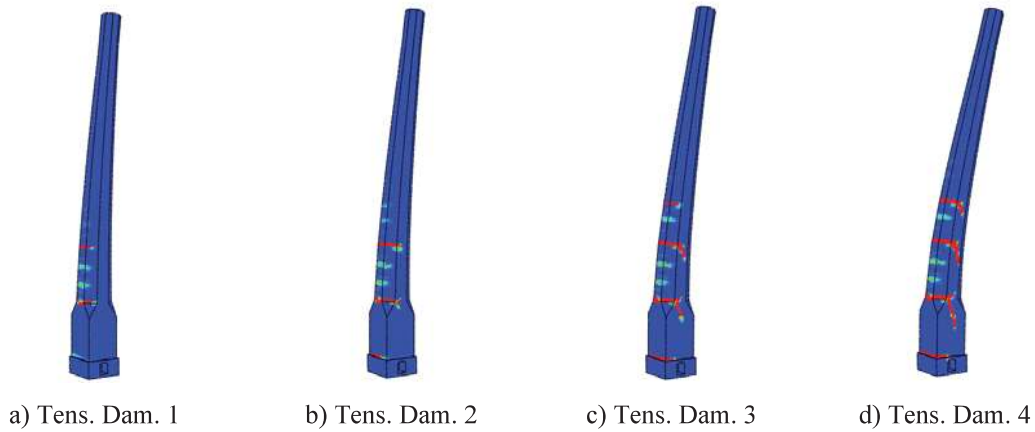

Figure 9: Comparison between the G1 and G2 loads' application along the z+ direction.

It could be interesting to highlight the phases of the damage spread. All the cases behave qualitatively similar due to the approximative axial symmetry of the structure; thus, the damage evolution of the z+ case is taken as an example and presented in Figure 10. It is shown how the loss of linearity is due to some horizontal cracks born on the tended fibres at a height between 5m and 9m; then, an additional horizontal crack born at the base. The plateau is approached when the aforementioned cracks spread and propagate as inclined along the faces parallel to the pushover load until collapse. Moreover, it is worth noting that the most critical sections are those at a quota between 5m and 9m. The damage maps suggest that a collapse mechanism based on a plastic hinge mechanism is activated. Based on [11], it is one of the most probable collapse mechanisms in tower-like structures under seismic actions when the structural slenderness is considerable.



e) Capacity curve

Figure 10: Damage evolution in z+ pushover.

3 SENSITIVITY ANALYSES ON THE VISCOSITY PARAMETER

A sensitivity analysis is proposed to highlight how the viscosity parameter value influences the analysis's results. The authors decided to select the G1 load and the z+ direction and varying the viscosity parameter only (the used values are shown in Table 3).

Viscosity parameter
0.001
0.0005
0.0001
0.00005

Table 3: Viscosity parameter's values used for the sensitivity analysis

Figure 11 shows the results of the sensitivity analysis. It is noticeable that the ultimate capacity significantly increases when the viscosity parameter is incremented. Moreover, the capacity curve's length is directly proportional to the viscosity parameter's value (the total load

increments number is fixed to 1200). The authors expected both the latter facts since the viscosity parameter smooth the yield surface and helps the steps' convergence and speed up. Increasing the viscosity parameter also increases the efficiency of the analysis by allowing larger load increments at each step but overestimate the ultimate capacity. Therefore, those who use the Concrete Damage Plasticity model in their studies must be aware of that and critically analyse the analyses' results also in light of the selected viscosity parameter's value.

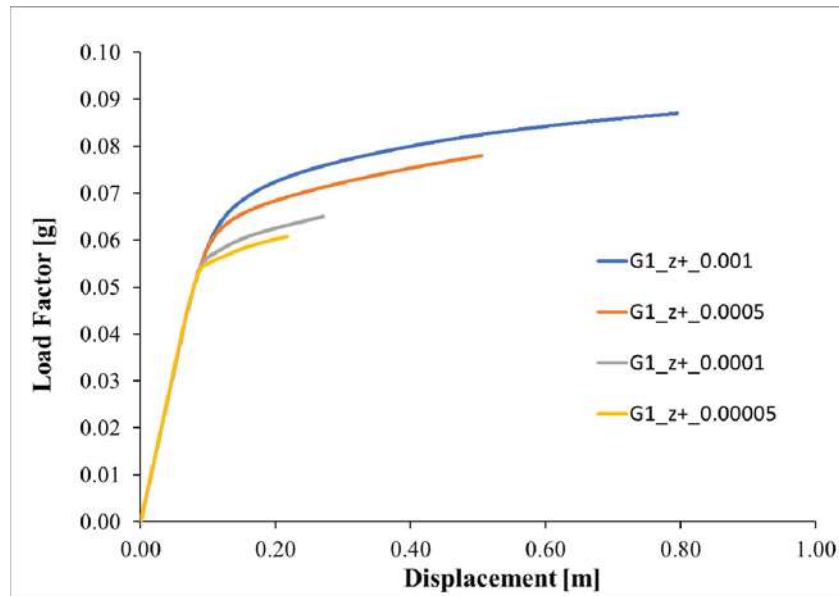

Figure 11: Sensitivity analysis on the viscosity parameter value.

4 CONCLUSIONS

This study has presented some FE simulations carried out on a real 20th-century masonry chimney located in Villar del Arzobispo (Spain). Pushover analyses have been carried out using the FE software Abaqus/CAE on a quite accurate 3D model of the case-study. Different simulations have been presented: various pushover analyses along the chimney along the four principal directions, using both G1 and G2 load distributions. The material properties have been chosen according to previous studies carried out on similar structures because no specific experimental data were available, and the plastic properties have been represented through the Concrete Damage Plasticity (CDP) model, which is an Abaqus built-in material model, widely used to represent the non-linear behaviour of masonry structures.

The results have been used to compare the capacity curves between each other and point out that the main weak points of the chimney are the cross-sections at a quota between 5m and 9m. Finally, a sensitivity analysis has been done on the viscosity parameter. The latter one is a numerical input value of the CDP, and it helps the analysis's steps to converge by smoothing the yield surface. It has been often highlighted that the viscosity parameter increment tends to overestimate the ultimate capacity. On the other hand, the decreasing of the viscosity parameter increase the computational cost; therefore, a sensitivity analysis on this parameter may be helpful to better understand the influence of this parameter on the pushover results. Results confirmed that the viscosity parameter significantly affects the ultimate capacity.

This paper aims to present an overview of the seismic vulnerability of the selected case-study. These results allowed to estimate the order of magnitude of the collapse acceleration and the main weak points of the structure. Moreover, the results have shown the importance of the modelling choices in terms of numerical parameters of the material model. However,

different windows remain open, and the authors intend to continue the research work carrying out non-linear dynamic analyses with both real and artificial accelerogram and testing innovative and simplified methods that would allow fast analyses (which might be useful in case of scale campaigns) or the calculation of the ultimate displacements needed to carry out eventual Displacement Based Design procedures. In this framework, simplified beam models or kinematic limit analysis procedures might be applied.

REFERENCES

- [1] D'Ambrisi A, Mariani V, Mezzi M. Seismic assessment of a historical masonry tower with non-linear static and dynamic analyses tuned on ambient vibration tests. *Eng Struct* 2012;36:210–9. <https://doi.org/10.1016/j.engstruct.2011.12.009>.
- [2] Milani G, Casolo S, Naliato A, Tralli A. Seismic assessment of a medieval masonry tower in Northern Italy by limit, nonlinear static, and full dynamic analyses. *Int J Archit Herit* 2012;6:489–524. <https://doi.org/10.1080/15583058.2011.588987>.
- [3] Ge, C. MZT. Research on the Safety Evaluation of Ancient Stone Pagodas in the Earthquake: a Case Study of Qingjing Pagoda. *Chinese Cult Reli Res* 2013;(02):46-50.
- [4] Jianli Y, Shengcai L. Study of the seismic damage regularity of ancient masonry pagodas in the 2008 Wenchuan Earthquake. *WIT Trans Built Environ* 2013;132:421–32. <https://doi.org/10.2495/ERES130341>.
- [5] Bertolesi E, DelGrosso A, Milani G, Minghini F, Tralli A. 3D FE pushover and non-linear dynamic analyses of a masonry chimney before and after shortening. *COMPdyn 2015 - 5th ECCOMAS Them. Conf. Comput. Methods Struct. Dyn. Earthq. Eng.* 2015:2158–66. <https://doi.org/10.7712/120115.3529.722>.
- [6] Formisano A, Milani G. Seismic vulnerability analysis and retrofitting of the SS. Rosario church bell tower in Finale Emilia (Modena, Italy). *Front Built Environ* 2019;5. <https://doi.org/10.3389/fbuil.2019.00070>.
- [7] Peña F, Lourenço PB, Mendes N, Oliveira D V. Numerical models for the seismic assessment of an old masonry tower. *Eng Struct* 2010;32:1466–78. <https://doi.org/10.1016/j.engstruct.2010.01.027>.
- [8] Casolo S, Milani G, Uva G, Alessandri C. Comparative seismic vulnerability analysis on ten masonry towers in the coastal Po Valley in Italy. *Eng Struct* 2013;49:465–90. <https://doi.org/10.1016/j.engstruct.2012.11.033>.
- [9] Valente M, Milani G. Non-linear dynamic and static analyses on eight historical masonry towers in the North-East of Italy. *Eng Struct* 2016;114:241–70. <https://doi.org/10.1016/j.engstruct.2016.02.004>.
- [10] Poiani M, Gazzani V, Clementi F, Milani G, Valente M, Lenci S. Iconic crumbling of the clock tower in Amatrice after 2016 central Italy seismic sequence: Advanced numerical insight. *Procedia Struct Integr* 2018;11:314–21. <https://doi.org/10.1016/j.prostr.2018.11.041>.
- [11] Sarhosis V, Milani G, Formisano A, Fabbrocino F. Evaluation of different approaches for the estimation of the seismic vulnerability of masonry towers. vol. 16. Springer Netherlands; 2018. <https://doi.org/10.1007/s10518-017-0258-8>.
- [12] Milani G. Fast Vulnerability Evaluation of Masonry Towers by Means of an Interactive and Adaptive 3D Kinematic Limit Analysis with Pre-assigned Failure Mechanisms. *Int J Archit Herit* 2019;13:941–62. <https://doi.org/10.1080/15583058.2019.1645241>.
- [13] Milani G, Shehu R, Valente M. A kinematic limit analysis approach for seismic retrofitting of masonry towers through steel tie-rods. *Eng Struct* 2018;160:212–28.

- <https://doi.org/10.1016/j.engstruct.2018.01.033>.
- [14] Grillanda N, Valente M, Milani G. ANUB-Aggregates: a fully automatic NURBS-based software for advanced local failure analyses of historical masonry aggregates. *Bull Earthq Eng* 2020;18:3935–61. <https://doi.org/10.1007/s10518-020-00848-6>.
- [15] Ferrante A, Clementi F, Milani G. Dynamic behavior of an inclined existing masonry tower in Italy. *Front Built Environ* 2019;5:1–16. <https://doi.org/10.3389/fbuil.2019.00033>.
- [16] D’Altri AM, Milani G, de Miranda S, Castellazzi G, Sarhosis V. Stability analysis of leaning historic masonry structures. *Autom Constr* 2018;92:199–213. <https://doi.org/10.1016/j.autcon.2018.04.003>.
- [17] Prizeman OEC, Sarhosis V, D’Altri AM, Whitman CJ, Muratore G. MODELLING from the PAST: The LEANING SOUTHWEST TOWER of CAERPHILLY CASTLE 1539-2015. *ISPRS Ann Photogramm Remote Sens Spat Inf Sci* 2017;4:221–7. <https://doi.org/10.5194/isprs-annals-IV-2-W2-221-2017>.
- [18] Vaiano G, Venanzi I, Formisano A, Ubertini F. Seismic behaviour of isolate and aggregate masonry towers: The case study of the sciri tower in Perugia. *COMPADYN Proc* 2019;1:1441–59. <https://doi.org/10.7712/120119.7010.19301>.
- [19] López-Patiño G, Adam JM, Verdejo Gimeno P, Milani G. Causes of damage to industrial brick masonry chimneys. *Eng Fail Anal* 2017;74:188–201. <https://doi.org/10.1016/j.engfailanal.2017.01.014>.
- [20] Minghini F, Bertolesi E, Del Grosso A, Milani G, Tralli A. Modal pushover and response history analyses of a masonry chimney before and after shortening. *Eng Struct* 2016;110:307–24. <https://doi.org/10.1016/j.engstruct.2015.11.016>.
- [21] Bamonte P, Cardani G, Condoleo P, Taliercio A. Crack patterns in double-wall industrial masonry chimneys: Possible causes and numerical modelling. *J Cult Herit* 2021;47:133–42. <https://doi.org/10.1016/j.culher.2020.09.001>.
- [22] Lopes V, Guedes JM, Paupério E, Arde A, Costa A. Ambient vibration testing and seismic analysis of a masonry chimney. *J Build Apprais* 2009;5:101–21. <https://doi.org/10.1057/jba.2009.24>.
- [23] Lourenço PB. Recommendations for restoration of ancient buildings and the survival of a masonry chimney. *Constr Build Mater* 2006;20:239–51. <https://doi.org/10.1016/j.conbuildmat.2005.08.026>.
- [24] Anzani A., Baila A., Bamonte P, Condoleo P, Togliani C. Structural survey of a chimney between XIX and XX century 2012.
- [25] Bamonte P, Taliercio A. Understanding crack patterns in masonry chimneys. *Procedia Struct Integr* 2018;11:322–30. <https://doi.org/10.1016/j.prostr.2018.11.042>.
- [26] De Iasio A, Wang P, Scacco J, Milani G. Longhu pagoda: Advanced numerical investigations for assessing performance at failure under horizontal loads (under review). *Eng Struct* 2021.
- [27] Smith M. ABAQUS/Standard User’s Manual, Version 6.9. United States: Dassault Systèmes Simulia Corp; 2009.
- [28] Magenes G, Morandi P, Penna A. Test results on the behaviour of masonry under static cyclic in plane lateral loads, 2008. Deliverable Project No. Coll – Ct - 2003 - 500291 ESECMaSE Enhanced Safety and Efficient Construction of Masonry Structures in Europe