

# **A MODELLING FRAMEWORK FOR DATA-DRIVEN DESIGN FOR SUSTAINABLE BEHAVIOUR IN HUMAN-MACHINE INTERACTIONS**

**Montecchi, Tiziano (1);  
Becattini, Niccolo' (2)**

1: Universidad Técnica Federico Santa María, Chile;  
2: Politecnico di Milano, Italy

## **ABSTRACT**

As the society is already permeated by data, a data-driven approach to inform design for sustainable behaviour can help to identify misbehaviours and target sustainable behaviours to achieve, as well as to select and implement the most suitable design strategies to promote a behavioural change and monitor their effectiveness. This work addresses the open challenge of providing designers with a model for Human-Machine Interactions (HMI) that helps to identify relevant data to collect for inferring user behaviour related to environmental sustainability during product use.

We propose a systematic modelling framework that combines constructs from existing representation techniques to identify the most critical variables for resources consumption, which are the determinants of potential misbehaviours related to HMI. The analysis is represented as a Behaviour-Inefficiency Model that graphically supports the analyst/designer to link user behaviours with a quantitative representation of resources consumption.

The paper describes the model through an example of the use of a kettle and an additional application of the same approach to a washing machine, in order to point out its versatility for modelling more complex interactions.

**Keywords:** Product modelling / models, Sustainability, Big data, Behaviour Change, Process modelling

## **Contact:**

Becattini, Niccolo  
Politecnico di Milano  
Mechanical Engineering  
Italy  
niccolo.becattini@polimi.it

**Cite this article:** Montecchi, T., Becattini, N. (2021) 'A Modelling Framework for Data-Driven Design for Sustainable Behaviour in Human-Machine Interactions', in *Proceedings of the International Conference on Engineering Design (ICED21)*, Gothenburg, Sweden, 16-20 August 2021. DOI:10.1017/pds.2021.16

## 1 INTRODUCTION

The improvement of technical systems is one of the key issues to address, at least some of, the 17 Sustainable Developments Goals (SDG) set with the 2030 Agenda of the [United Nations \(2015\)](#). Technical systems with higher efficiency, in fact, enable saving a potentially large amount of resources: from the reduction of energy waste (as for [SDG#7](#)) to the shrewd use of water in order to preserve its quality within the environment (as for [SDG#6](#)). These demands call designers to contribute with the identification of opportunities, the ideation and the development of breakthrough solutions. In the last three decades eco-design approaches have been integrating environmental issues into product development ([McAloone and Pigosso, 2017](#)) and different methods and tools are now available to support designers in their activities (e.g. [Russo et al., 2011](#); [Telenko et al., 2016](#)). Nevertheless, these endeavours just address part of the problem. In fact, the way we, as users, interact with the technical systems could potentially baffle most of the efforts to increase their efficiency or to save/preserve natural resources. For this reason, within the last decade, a research stream has started considering design as a way to implement solutions that trigger behaviour change ([Lockton et al., 2010](#)) and sustainable behaviours in particular ([Coskun et al., 2015](#)). The recent diffusion of technologies that are capable of collecting data from different sources (such as internet of things as well as wearable devices) opens up avenues to explore the behaviour of the user when it interacts with a technical system (e.g. [Scurati et al., 2019](#)). These data complement the designers' talent as they inform its activity with fact-based evidence to ground design moves and choices. Among the different role data play in this context, they can inform the designer about misbehaviours and the target sustainable behaviour to achieve. Moreover, data can support the selection of the best design strategy for behaviour change as well as check the effectiveness of the proposed solution in triggering a sustainable behaviour ([Montecchi and Becattini, 2020](#)). However, there are still some challenges to make this data-driven approach informative for design. In fact, the collection of data to infer user behaviour broadens the designers' focus from the ideation and the development of the solution to include also the definition of the relevant data to acquire, the pipeline for processing and analysis and their use in the design of the solution ([Cantamessa et al., 2020](#)).

This paper aims at defining a modelling framework for designers to identify relevant data to collect for inferring user behaviour and inform the design of solutions capable of triggering a sustainable behaviour. The modelling framework is based on the original combination of existing constructs and their representations. More in detail, it will particularly address environmental sustainability, by means of mapping the critical variables related to the flows of resources and the sequences of activities in Human-Machine Interaction (HMI) that present efficiency losses/inefficiencies (i.e. excessive consumption or waste of resources due to misbehaviours).

For this purpose, the next section reviews some of the extant modelling techniques, in order to highlight their purpose, their constructs and their suitability for the adoption into a modelling framework to support design for sustainable behaviour. Section 3 details the modelling framework together with a systematic procedure to represent its constructs and extract a list of parameters to monitor during data acquisition for further processing. Section 4 shows an example of application together with a discussion of the strengths and weaknesses of the proposal. The concluding section summarizes the findings, presents their implications and depicts opportunities for further developments.

## 2 ANALYSIS AND SELECTION OF RELEVANT MODELLING CONSTRUCTS

Most of the available contributions in the literature that deals with the identification of (mis)behaviours in terms of environmental sustainability are based on techniques that observe the human during its interaction with a machine/technical system. They range from live techniques, such as field observations and ethnographical studies (e.g. [Bahmra et al., 2011](#)), to approaches that require the user to reflect on its habits during interviews or when filling a questionnaire (e.g. [Elias et al., 2011](#)). For what concerns the modelling of HMI, different approaches tackle different elements of such an interaction. On the one hand, a review by [Sankowski and Krause \(2018\)](#) clarifies that the interaction can take place at both physical and mental level, substantially highlighting that, beyond what can be observed, there is an implicit dimension that concerns the user intentions. On the other hand, [Khadilkar and Cash \(2020\)](#) stressed the relationship between the machine and the human, underlining that the former can trigger a behavioural effect on the user, as highlighted by both [Roozenburg and Eekels \(1995\)](#), and that the user interacts with the machine to get one or more of its needs satisfied, as for [Hubka and Eder \(2012\)](#).

However, to the authors' knowledge, there are no contributions in the literature that guide the designer to choose a relevant set of data to collect, so that it becomes possible to infer the user's behaviour or to assess the sustainability of the HMI. For this reason, Table 1 classifies some of the most diffused modelling techniques and/or approaches in the design field as they are proposed by their authors or as scholars use them. This is to highlight their capabilities and potential opportunities for a combination of their constructs into a tailored modelling framework. Despite Table 1 could provide a non-comprehensive overview of relevant alternatives for representation of concepts, these are sufficient to highlight existing constructs that might be relevant to support the identification of (mis)behaviours and the definition of data capable of describing them (in columns). In fact, the identification of unsustainable behaviours related to the product use phase, the one we are focusing on, depends on the capability of describing the processes through which a human interacts with a machine (process) as well as the way the machine works (product/process) and how it elaborates the flow of resources it deals with. Moreover, as the purpose is to grasp potentially unsustainable behaviours, a further set of relevant modelling techniques deals with problems/conflicts that can emerge because of misbehaviours. References, acronym meanings and more detailed descriptions, with examples of application, are available in [Becattini \(2013\)](#).

*Table 1. Constructs considered in approaches/representation techniques relevant to capture (mis)behaviours in Human-Machine Interaction - quantitative representations in italic*

Name	Focus	Resource flow	Purposes Functions	Activities Behaviour	Structural Hierarchy	Event (time)	Causal Relationships
BPMN 2.0	Process	X	X	X		X	
EMS	Process	X	X	X	X	X	
Function tree	Process		X				X
IDEF0	Process	X	X	X	X	X	
<i>Petri Net</i>	<i>Process</i>			X		X	X
<i>Sankey</i>	<i>Process</i>	X		X			
SAPPhIRE	Product	X	X	X	X		X
TRIZ SuField	Product	X	X				
DSM	Prod/Proc				X		X
<i>EAV model</i>	<i>Prod/Proc</i>				X		
FBS	Prod/Proc		X	X			
TRIZ System Operator	Prod/Proc + Problem	X			X	X	
Fault Tree	Problem		X	X	X	X	X
Fishbone	Problem		X	X			X
FMEA	Problem			X		X	X
TRIZ Contradiction	Problem			X			X

Table 1 shows that, per se, none of the above captures all the relevant elements to spot environmentally harmful user behaviours and HMI-related data that enable to infer them. Thus, we need to combine constructs from different modelling approaches. Despite the Energy-Material-Signal (EMS by [Pahl and Beitz, 2013](#)) and IDEF0 ([ISO, 2019](#)) models thoroughly provide comprehensive qualitative descriptions of processes, they are not sufficient to highlight which quantitative data should be collected to infer user behaviours. A quantitative description of flows of resources is necessary to highlight data to be collected to infer (mis)behaviours, showing opportunities of integration with Sankey Diagrams ([Schmidt, 2008](#)). While this accounts for the visualization of flows, quantitative data description also requires a strong formalism that is potentially compatible with data and information processing systems, such as the Entity-Attribute-Value model (EAV e.g. [Nadkarni et al., 1999](#)). Moreover, some of the Function-Behaviour-Structure (FBS) constructs ([Gero and Kannengiesser, 2004](#)) can clarify what a misbehaviour is. Extending the concept of expected behaviour (Be) and behaviour of the structure (Bs) to HMI, Be should represent a sustainable user behaviour (target), while Bs is for the actual one. A mismatch between Be and Bs highlights a potential misbehaviour to be measured through data. However, none of these approaches explicitly deals with problems, despite all the related techniques in Table 1 represent

them with causal relationships. These should be conveniently included in the model by making explicit cause-and-effect links among activities consuming resources.

### **3 AN HUMAN-MACHINE INTERACTION MODEL TO COLLECT DATA FOR BEHAVIOURAL ANALYSIS**

#### **3.1 A new modelling framework**

This work stems from the observation that systems have a certain level of efficiency defined by designers' intentions, but users can lower this efficiency with (conscious or unconscious) misbehaviours that generate additional consumption of resources. The proposal consists of six steps that guide designers in modeling user behaviours belonging to the use phase. This starts from identifying the inefficiencies as a comparison between the target and the actual resources consumption (steps 1-4). From these inefficiencies, the designer can move backward to the identification of misbehaviours following the dependencies among the activities the user carries out and the impact these have on the way the system works (step 5). The final step aims at clarifying what are the data to be acquired in order to identify potential misbehaviours in real product use. This can support designers for sustainable behaviour to define what device for data acquisition (e.g. IoT) should be introduced into products and what data they should capture to return the designers with relevant information about product (mis)use. The following subsections present the steps together with an example of usage of a low complexity product, i.e. the kettle. The example highlights how the model represents the consumption of resources and how it enables the estimation of inefficiencies to identify the critical variables to describe user misbehaviours. Beyond the example, the modelling technique relies on constructs that are versatile to represent a large variety of human interactions with machines/products characterized by different complexity.

##### **3.1.1 Step 1 - Definition of machine goals and humans intentions**

To deal with the problem of identifying unsustainable behaviours during the use phase, it is necessary to consider both sides of the interaction problem: the user and the technical system.

On the user side, its goal are linked to intentions and needs, i.e. what it wants to do with the system (Sankowski and Krause, 2018). On the product's side, the system has to deliver a function to meet technical requirements, which are, in turn, the designer's interpretation of user's needs, i.e. what the system can do to satisfy user needs. According to the FBS perspective, this function (F) is intended as the purpose of the system existence, i.e. what it is for (Gero and Kannengiesser, 2004).

*In our example, the human's intention of using the kettle is boiling water to make a cup of tea and the goal of the system is to heat up a certain amount of water. The sustainability of using a product has to be evaluated according to the user's intention. The consumption of the water cup and the thermal energy for its heating needs to be considered a necessary consumption of resources and they cannot to be considered inefficiencies, i.e. to make a cup of tea, kettles need a certain amount of water and energy.*

##### **3.1.2 Step 2 - Identification of Resources flows**

The analysis of resources consumption can be supported by the EMS model (Pahl and Beitz, 2013) that represents the product as a technical system carrying out its function through a transformation of flows of Energy, Material and/or Signal. This transformation (Function in FBS terms), is carried out through sequential changes of state for the EMS flows, interpretable as the system Behaviour (Umeda et al., 1995). There are two behaviours to consider: the expected behaviour (Be), intended as the one reflecting designer's intentions and the behaviour of the structure (Bs), which is the actual behaviour synthesized through the system's structure. The authors extend this concept in the perspective of HMI, where the behaviour of the system is determined also by the user behaviour. Thus, in this work the Be includes the correct/target behaviour of the user as expected by designer intentions, the Bs includes the actual behaviour of the user. Figure 1 represents the Be and Bs. The first uses the exact amount of water needed for a cup of tea (0,2l) heating it up from 5°C (temperature of tap water) at 90°C (recommended temperature for tea). An example of misbehaviour (Bs) may be the use of an extra amount of water that produces a waste of energy and is finally left inside the kettle as a waste.

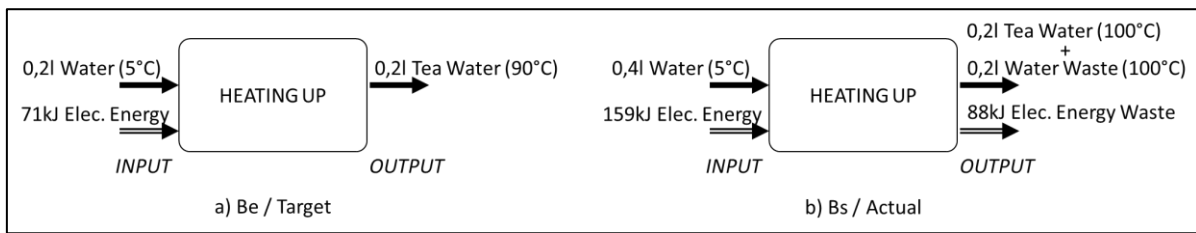

Figure 1. EMS model applied to the kettle system: Be versus Bs

### 3.1.3 Step 3 - Decomposition of the usage process in Human and Machine Behaviours

To identify the human misbehaviours related to the use process of a product, it is fundamental to model the entire sequence of activities carried out by humans and machines. The boundaries of the process analysis are determined by the exhaustive mapping of all transformations of EMS flows, whether they are made by machines or humans (e.g. *the process of using kettle does not end when the user puts the kettle back on its base, but when the tea water is drunk*). The entire use process needs to be decomposed into a chronological sequence of activities, which can be distinguished into four typologies.

**Human Activities.** These describe activities performed by users. They are divided into:

- **Human Functions (HF).** Functions performed on the EMS flows by users. *For example, the user changes the water position to fill the kettle (this can determine that water may be at room temperature or colder coming from the tap); the user cools down water (e.g. once the tea bag has been infused, the user may add cold water to reach a drinkable temperature).*
- **Human-Machine interactions (HMI).** Functions performed by the users to change technical system (working) conditions. These interactions are typically related to the preparation of the machine before and after its working phases (e.g. *open/close the kettle cap, the user puts the kettle on top of its base*), thus including the function to control the machine e.g. *the user presses the on button of the kettle (which deals with a signal flow)*.

**Machine Activities.** Functions performed by machines are divided into:

- **Machine Functions (MF).** Functions performed on the EMS flows by the technical system. Not only the main function (i.e. *the kettle heats water*) needs to be considered but also other functions can be relevant for the EMS flows analysis (e.g. *the filter retains impurities and limescale*).
- **Machine-Human interactions (MHI).** Functions performed by the technical system on the users. These functions differ greatly with products, from informing and giving feedback to the users (e.g. *the click sound alerts the ending of heating water function.*), to generating more physical actions for those products where the transformation of the user is the goal of the function (e.g. a massage chair, jacuzzi).

The analysis requires mapping EMS flows as input/outputs for the whole set of activities composing the entire use process. The designer can adapt the EMS model, using a hierarchical representation, to analyse the use process at different detail levels considering simultaneously the main transformation of the process as well as the entire sequence of functions above presented. In this way, the analysis can be adapted to the scope and deepened those phases where the consumption of resources is greater.

### 3.1.4 Step 4 - Evaluation of inefficiencies

In the engineering context, the concept of inefficiency is typically associated to the system transformation. In this work, the authors propose to focus the attention on the additional inefficiency generated by the misuses of the product. This extra consumption is the difference between the "target consumption", coherent with the product use as it was designed and the "actual consumption" generated by the user interaction with the system, respectively Be and Bs according to the extension of the FBS concept (presented in section 3.1.2). The **target consumption** overlooks that no machine/system is ideal, as the inefficiencies to map here are not related to the intrinsic inefficiency of machine (its efficiency is less than one according to the laws of energy conservation). Target consumption, therefore, maps what is needed for the machine to work according to the designer's intention. Nevertheless, the user may have a wrong or poor interpretation of the same, therefore affecting this target consumption through misbehaviours, which generate additional efficiency losses, i.e. measurable through the system's **actual consumption**. With reference to these conditions, the Human Behaviour Inefficiency (HBI) of using a product can be defined as:

$$HBI = \frac{X_{actual} - X_{target}}{X_{target}} \quad (1)$$

Where,  $HBI$  is the inefficiency due to human behaviour when using a product/machine,  $X_{actual}$  and  $X_{target}$  define respectively the actual and target consumption of any  $X$  resource among EMS. This equation leads to the following three conditions, which can be represented in Figure 2 for the kettle example.

- If  $X_{actual} > X_{target}$ , then  $HBI > 0$ , i.e. the user behaviour generates inefficiency. The considered  $X$  resource has been exploited more than the target consumption defined by designer's intentions.
- If  $X_{actual} = X_{target}$ , then  $HBI = 0$ , i.e. the product has been used according to the designer's intentions.
- If  $X_{actual} < X_{target}$ , then  $HBI < 0$ , i.e. the product has not been used according to the designer's intentions. Moreover, the quantity of  $X$  resource is less than the adequate one to match the user's intentions. This can leave the user unsatisfied, requiring the product to be used again, making the use of resources inefficient as for  $HBI > 0$ .

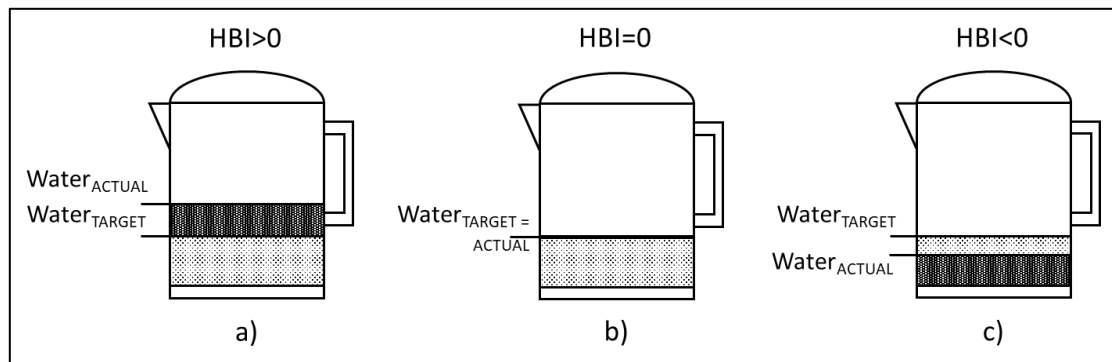

Figure 2. Example of inefficiency ( $I$ ) represented different conditions of water consumption ( $X$ ) for the kettle. The target quantity of water is defined according to the user intention

### 3.1.5 Step 5 - Detection of unsustainable behaviours through dependencies among activities

While inefficiencies occur among machine activities, user misbehaviours are specific of human activities. Seeking for the root-causes of inefficiencies, the designer can establish the link with user behaviours (e.g. *filling more water than necessary generates energy inefficiency during water heating*).

The modelling of such dependencies can be supported by an approach that makes explicit causal relationships, as mentioned in section 2. The inefficient consumption is the effect (*consuming more energy to heat water*) and the human behaviour, reflected by its activities, are the causes (*introducing more water into the kettle*). By means of dependencies, designers can move backward from inefficiencies to misbehaviours and specifically look for misbehaviour within the two types of human activities (HF and HMI). In the following, we present further details useful to support designers to identify misbehaviours.

**Misbehaviours related to Humans Functions (HF).** With respect to the input flows, the user excessively exploits a resource compared to its real needs (e.g. *introducing inside the kettle more water than is needed*). With respect to the output flows, the user does not fully exploit the processed output of the machine. The results of the transformation are excessive (e.g. *the water temperature is higher than needed*) or they change (e.g. on time) and no longer meet the user needs (e.g. *letting the water cool down inside or outside the kettle without using it*).

**Misbehaviours related to Humans-Machine Interactions (HMI).** This type of behaviour occurs when the user directly interacts with the machine by changing the way it works. Examples of this behaviour can be an incorrect programming of the machine (e.g. *letting the kettle switch off automatically even when water is needed at a temperature below boiling point*). Moreover, this can also occur when an activity is (consciously or unconsciously) skipped or performed differently from the designer's recommendations (e.g. *leaving the lid of the kettle open during the heating process*).

### 3.1.6 Step 6 - Elicitation of parameters associated with the flows transformations

The goal of the last step is to identify those variables that are determinants of potential user misbehaviours and that can be used to inform design for sustainable behaviour in a data-driven context. Any difference between the target and actual consumption can be described in terms of parameters related to the transformations of flows. To extract parameters, designers must know the

physics underlying the system's functioning and thus describe Be and Bs. These parameters can be mapped according to the Entity-Attribute-Value (EAV) model (Nadkarni et al., 1999) that allows to describe the parameters change between the target and actual consumption of flows (Table 2).

As example, the authors propose the identification of those parameters related to the unsustainable behaviour of "introducing more water than needed", Table 2. The weight of water is a parameter that may be used to monitor this misbehaviour. The weight can be measured in different use phases and the misbehaviours may be detected as difference between the water filled and water left inside the kettle after the use. Similarly, we may measure the volume of water (e.g. the water level) or the empty volume of the kettle. The choice of which parameter is more suitable to be monitored is a design decision that needs to consider a wide range of issues, such as the availability of data, the requirements of the sensing device, its integration within the product analysed, its impact on the user, etc. Using the same approach, the designer may choose to assess the quantity of energy wasted in heating the unnecessary amount of water, for example triangulating the consumption of the electric energy absorbed by the appliance with water weight, rather than the heating time or temperature difference between input/output water.

Table 2. EAV model representing parameters related to using more water than needed (Bs) and the corresponding inefficiencies (I) of water and energy wastes

Entity	Attribute	Value (Actual)	Value (Target)
Water	Weight	0,4kg	0,2kg
Water	Volume	0,4l	0,2l
Energy consumption	Absorption	159kJ	71kJ
Energy consumption	Heating time	75sec	48sec
Energy consumption	Mass of water left / Water $\Delta T$	0,2kg / 85°	0kg / 85°

These parameters can support different tasks of the design for sustainable behaviour. Their analysis with a data-driven approach enables designers to detect unsustainable behaviours. Moreover, they can also enable the definition of target behaviours and support the implementation of extant design strategies to promote behavioural changes (e.g. using the feedback strategy, the user could be informed about the extra energy consumed or the corresponding increase of the electricity bill). Eventually they can help evaluate the impact of new solutions for behaviour change in longitudinal studies.

### 3.2 Graphical Representation of the Human Behaviour Inefficiency Model

The framework presented in the previous sections, the Human Behaviour Inefficiency Model, can be represented graphically to facilitate the visualization of resources consumptions and their links with unsustainable behaviours (Figure 3). This representation integrates the Sankey Diagram (Schmidt, 2008), which allows to visually quantify the flows of resources. This graphical representation highlights:

- The use process decomposition into human (HF and HMI) and machine (MF and MHI) activities.
- The different typologies of resources and their quantitative consumption, EMS flows are represented with different colours and the consumption is proportional to the thickness of flows.
- The inefficiency, as a comparison between target and actual consumption, i.e. ( $X_{actual} - X_{target}$ ).
- The dependencies (represented by dotted arrows whose direction expresses the cause-effect relationship) between inefficiencies and misbehaviours to support the parameters identification.

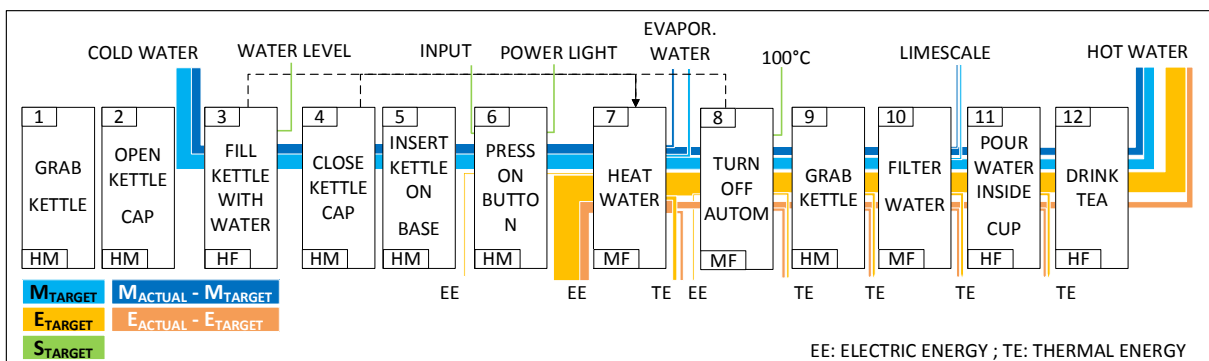

Figure 3. Human Behaviour Inefficiency Model of a kettle. Exemplary comparison between target and actual consumption

## 4 EXAMPLE OF MODEL APPLICATION

In this chapter, the framework is applied to the use of a real washing machine (F1485RD by LG). The authors present this example to show the applicability of the framework to more complex HMIs. The washing machine weighs the load and automatically sets the water quantity and the time for the cycle according to the program the user selects. The user, in turn, has to load the right amount of detergent and softener. The Human Behaviour Inefficiency Model of such a washing machine is represented in Figure 4. It shows the target consumption of the product usage. By means of dependencies (dashed lines), the analyst/designer can visualize the human activities that generate the highest impact on the resources. For example, the human activities of selecting the washing program (9) and loading clothes (4), detergent (5) and softener (6) are linked to the machine activities with the highest consumption: wash (11) and rinse (12) clothes. This means that these human activities (4, 5, 6, 9) can potentially multiply the resources consumption the machine needs to carry out its activities (11, 12).

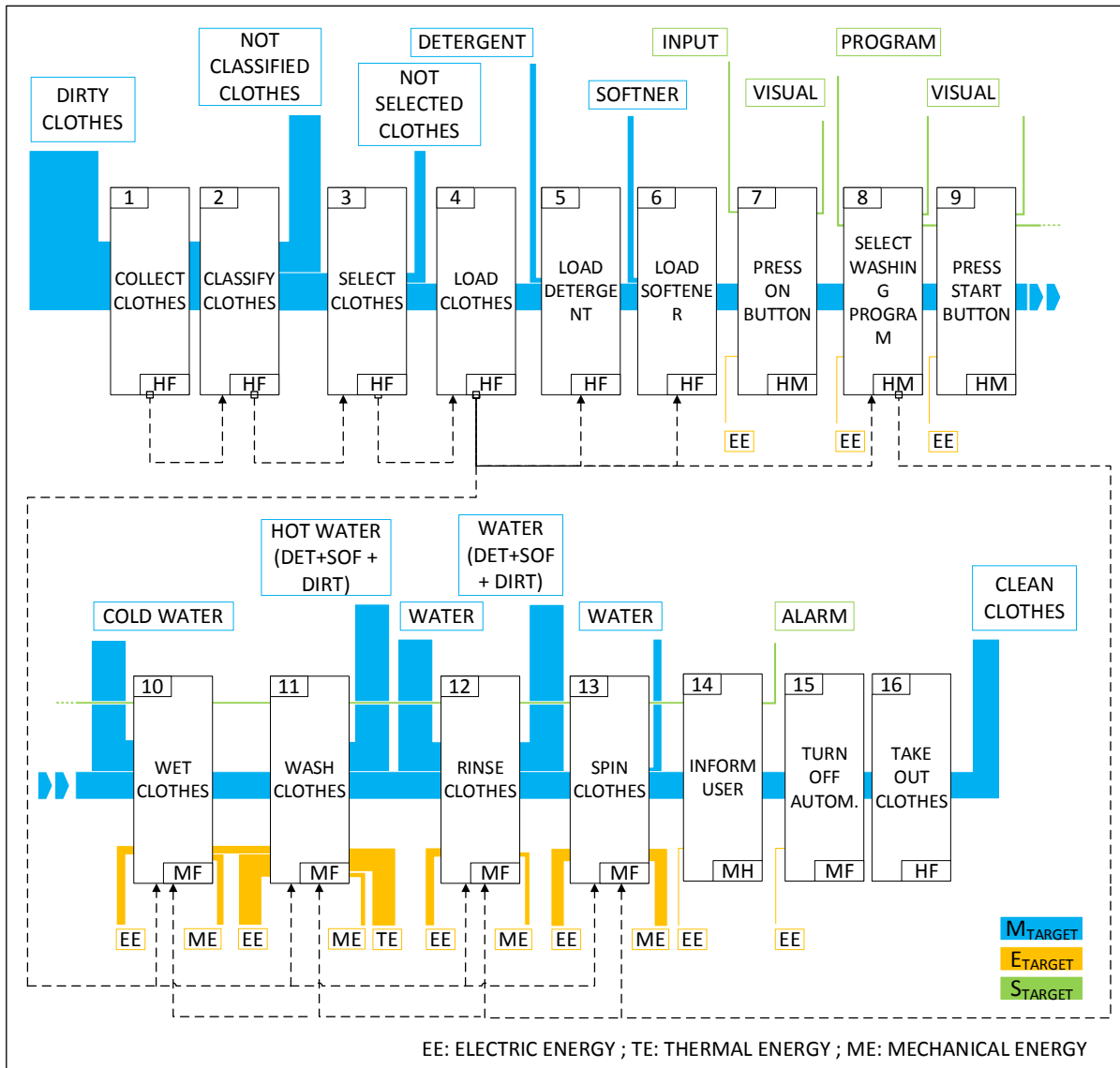

Figure 4. Human Behaviour Inefficiency Model of a washing machine. Exemplary analysis of target consumption (divided into two lines)

For the sake of brevity, the authors focus on only two steps (4 and 5) with high human involvement in order to show strengths and weaknesses of the proposal.

For the activity of loading clothes (4), a proper use involves "filling the full load capacity of the machine", this behaviour matches the designer intentions about the Be of the machine. On the contrary, "using the machine with a partial load" can be considered unsustainable and it generates an inefficiency onto the dependent activities of wash (11), rinse (12) and spin clothes (13), as shown by



the dotted arrows. Despite counterintuitive, as water quantity depends on the load, for certain operations the machine will use the same energy regardless of the load, e.g. the electric energy required by the engine to overcome initial inertia and start the rotation is always the same. To detect this misbehaviour, the designer can weigh the clothes through the indirect measurement of the drum weight. Alternatively, this can be estimated with the empty/filled volume of the drum. The model gives also the opportunity of using the dependencies to move forward along the sequence of activities and measure the engine torque during the drum rotation to have a further chance for detecting the load weight (the engine torque is proportional to the load weight). The model also allows the causes of the inefficient loading of clothes (4) as a consequence of other activities, such as collect clothes (1) (e.g. the time lapsed from the last wash, the habits of changing, clothing, etc.), classify clothes (2) (e.g. classification by colour, material, dirt level, etc.), select clothes (3) (e.g. quantity of clothes).

With the same approach, we can analyse other misbehaviours. For example during the phase of loading detergent (5), users may introduce a lower/higher amount of detergent in relation of what needed by load and water level. A lower amount of detergent does not permit to clean clothes properly. On the contrary, an excessive amount of detergent produces higher water turbidity, potentially requiring one additional rinsing cycle. This unsustainable behaviour may be detected in various ways, for example by weighting the detergent dispenser or measuring the detergent flow rate. Alternatively, the model helps also to identify other monitoring possibilities just following the detergent flow and for example checking the chemical composition of the water discharge (output of wash clothes, step 11). Weighting the dispenser may also be a chance to detect the user action of bypassing the dispenser, often replaced by the introduction of the detergent directly inside the drum among clothes.

The model points out the key role of information needed by the user to use the machine according to its target behaviour, therefore to interpret designer intentions and behave in a sustainable way. To support designer in evaluating the information exchange, the model maps the resource of Signal (green flows in Figure 4), even if a proper quantification of this resource is still immature. With respect to the inefficiency, the authors believe that even the input and output information should be considered to calculate the inefficiency. This becomes evident in products that exploits Artificial Intelligence or Machine Learning algorithms to process huge amounts of data.

## **CONCLUSIONS**

This paper proposes a research for defining the overall framework of a novel modelling technique suitable to support design for sustainable behaviour based on a data-driven approach. In this context, the work stems from the lack of existing contributions to guide designers along the data collection to infer the user's behaviour or to assess the sustainability of the HMI.

This work introduces the concept of usage inefficiency that allows to identify and assess the excessive resources consumption determined by HMI along the phase of use of a product/machine. This inefficiency is able to point out the discrepancy between the target machine consumption conceived according to the designer intentions and the actual machine consumption due to the human interactions. Specifically, we propose a systematic modelling framework that originally combines constructs from existing representation techniques (EMS and FBS) to assess the consumption of resources, link them to the misbehaviours (root-cause analysis) and finally extract the critical variables/determinants that represent the data to be collected to inform design (Entity-Value-Attribute). The analysis can be supported by the Behaviour-Inefficiency Model, a quantitative diagram inspired to the Sankey diagram, that visually represents the dependencies between human behaviours and machine consumptions.

The applications of the Human Behaviour Inefficiency modelling framework have also proved to be effective for various products beyond the kettle and the washing machine proposed in this paper, with a good versatility and capability of organizing and mapping exhaustively the information for different levels of complexity of HMI. Nevertheless, these applications are limited to the analysis of a single use, while multiple/repeated uses of products could generate different impact on sustainability. Additionally, the applicability of the overall framework should be extended and validated within other areas beyond home appliances. It cannot also be ignored that the analyst needs adequate knowledge about the mechanisms driving the machine functioning which reflects the designer's intention.

The authors aim at extending this analysis to other phases of the lifecycle (e.g. purchase, maintenance, end of life) where user behaviours can affect environmental sustainability. Moreover, the potential integration with LCA enables the evaluation of Global Warming Potential, acidification, water use,

etc. In fact, this methodology allows to identify inefficiencies related to the use of Energy, Material and Signal that are heterogeneous and could be converted into indicators (e.g. CO<sub>2</sub>, CH<sub>4</sub>, N<sub>2</sub>O, etc.) to harmonize the analysis and assess the environmental impact of the users' misbehaviours as for Life Cycle Assessment (LCA).

## ACKNOWLEDGMENTS

The authors would like to thank Macarena Lobovsky from Universidad Técnica Federico Santa María for her contribution to the development of the cases studies.

## REFERENCES

- Becattini N. (2013) - D2.2 - Product and Process Modeling - State of the Art - Deliverable of the FORMAT Project - <http://www.format-project.eu/deliverables/public-reports-and-white-papers/deliverable-2.2/view>
- Bhamra, T., Lilley, D., & Tang, T. (2011). Design for sustainable behaviour: Using products to change consumer behaviour. *The Design Journal*, 14(4), 427-445.
- Cantamessa, M., Montagna, F., Altavilla, S., & Casagrande-Seretti, A. (2020). Data-driven design: the new challenges of digitalization on product design and development. *Design Science*, 6.
- Coskun, A., Zimmerman, J., & Erbug, C. (2015). Promoting sustainability through behavior change: A review. *Design Studies*, 41, 183-204.
- Elias, E. W. A. (2011). User-efficient design: Reducing the environmental impact of user behaviour through the design of products (Doctoral dissertation, University of Bath).
- Gero, J.S. and Kannengiesser, U., 2004. The situated function-behaviour-structure framework. *Design studies*, 25(4), pp.373-391.
- Hubka, V. and Eder, W.E., 2012. *Theory of technical systems: a total concept theory for engineering design*. Springer Science & Business Media.
- ISO/IEC/IEEE 31320-1:2012 Information technology — Modeling Languages — Part 1: Syntax and Semantics for IDEF0
- Khadilkar, P.R. and Cash, P., 2020, May. Discerning behavioural design: a conceptual model. In *Proceedings of the Design Society: DESIGN Conference* (Vol. 1, pp. 1455-1464). Cambridge University Press.
- Lockton D., Harrison D., Stanton N.A. (2010), Design for behaviour change, *Advances in Psychology Research*, Volume 67, , pp. 63-81.
- McAloone, T. C., & Pigosso, D. C. (2017). From ecodesign to sustainable product/service-systems: a journey through research contributions over recent decades. In *Sustainable Manufacturing* (pp. 99-111). Springer, Cham.
- Montecchi, T., & Becattini, N. (2020, May). Design for sustainable behavior: Opportunities and challenges of a data-driven approach. In *Proceedings of the Design Society: DESIGN Conference* (Vol. 1, pp. 2089-2098). Cambridge University Press.
- Nadkarni, P. M., Marengo, L., Chen, R., Skoufos, E., Shepherd, G., & Miller, P. (1999). Organization of heterogeneous scientific data using the EAV/CR representation. *Journal of the American Medical Informatics Association*, 6(6), 478-493.
- Pahl, G., & Beitz, W. (2013). *Engineering design: a systematic approach*. Springer Science & Business Media.
- Roozenburg, N.F.M. and Eekels, J. (1995), *Product Design: Fundamentals and Methods*, John Wiley & Sons Ltd, West Sussex, England.
- Russo, D., Regazzoni, D., & Montecchi, T. (2011). Eco-design with TRIZ laws of evolution. In *Innovative product design: 9th ETRIA World TRIZFuture Conference*, Timisoara, Romania, 4-6 November 2009 (Vol. 9, pp. 311-322). Elsevier Science
- Sankowski, O. and Krause, D., 2018, November. Using Multi-Channel Human-System Interaction for User-Centered Product Design. In *ASME International Mechanical Engineering Congress and Exposition* (Vol. 52187, p. V013T05A036). American Society of Mechanical Engineers.
- Schmidt, M. (2008). The Sankey diagram in energy and material flow management: part II: methodology and current applications. *Journal of industrial ecology*, 12(2), 173-185.
- Scurati, G. W., Huang, S., Wu, S., Chen, T., Zhang, Y., Graziosi, S., ... & Bordegoni, M. (2019, July). Multisensory nudging: a design intervention for sustainable hand-washing behavior in public space. In *Proceedings of the design society: International Conference on Engineering Design* (Vol. 1, No. 1, pp. 3341-3350). Cambridge University Press.
- Telenko, Cassandra, Julia M. O'Rourke, Carolyn C. Seepersad, and Michael E. Webber. 2016. A compilation of design for environment guidelines. *Journal of Mechanical Design* 138(3): 31102. <https://dx.doi.org/10.1115/1.4032095>
- UN, *Transforming Our World: The 2030 Agenda for Sustainable Development* (UN, New York, 2015);
- Umeda, Y., Tomiyama, T. and Yoshikawa, H., 1995, May. FBS modeling: modeling scheme of function for conceptual design. In *Proc. of the 9th int. workshop on qualitative reasoning* (pp. 271-8).