

Author's Accepted Manuscript

Topological risk mapping of runway Overruns: A probabilistic approach

Paolo Trucco, Massimiliano De Ambroggi, Maria Chiara Leva



PII: S0951-8320(15)00181-7
DOI: <http://dx.doi.org/10.1016/j.ress.2015.06.006>
Reference: RESS5341

To appear in: *Reliability Engineering and System Safety*

Received date: 15 July 2013
Revised date: 3 June 2015
Accepted date: 5 June 2015

Cite this article as: Paolo Trucco, Massimiliano De Ambroggi, Maria Chiara Leva, Topological risk mapping of runway Overruns: A probabilistic approach, *Reliability Engineering and System Safety*, <http://dx.doi.org/10.1016/j.ress.2015.06.006>

This is a PDF file of an unedited manuscript that has been accepted for publication. As a service to our customers we are providing this early version of the manuscript. The manuscript will undergo copyediting, typesetting, and review of the resulting galley proof before it is published in its final citable form. Please note that during the production process errors may be discovered which could affect the content, and all legal disclaimers that apply to the journal pertain.

Essential title page information

Topological Risk Mapping of Runway Overruns: a probabilistic approach

Paolo Trucco^a, Massimiliano De Ambroggi^a and Maria Chiara Leva^b

^a *Department of Management, Economics and Industrial Engineering
POLITECNICO DI MILANO
Piazza Leonardo Da Vinci, 32 - 20133 Milan, Italy
paolo.trucco@polimi.it
massimiliano.deambroggi@polimi.it*

^b *Centre for Innovative Human Systems CIHS - Department of Psychology
Trinity College, Dublin 2, Ireland
levac@tcd.ie*

Corresponding Author:

Prof. Paolo Trucco

*Department of Management, Economics and Industrial Engineering
POLITECNICO DI MILANO
Piazza Leonardo Da Vinci, 32 - 20133 Milan, Italy*

E-mail: paolo.trucco@polimi.it

Phone: +39 02 2399 4053

Topological Risk Mapping of Runway Overruns: a probabilistic approach

Paolo Trucco^a, Massimiliano De Ambroggi^a and Maria Chiara Leva^b

^a *Department of Management, Economics and Industrial Engineering
POLITECNICO DI MILANO
Piazza Leonardo Da Vinci, 32 - 20133 Milan, Italy
paolo.trucco@polimi.it
massimiliano.deambroggi@polimi.it*

^b *Centre for Innovative Human Systems CIHS - Department of Psychology
Trinity College, Dublin 2, Ireland
levac@tcd.ie*

Abstract

The paper presents a topological risk mapping for aircraft overruns. The proposed procedure is based on the study published in 2008 by Hall, Wong, & Ayres [1]. In that study the authors performed an analysis of aircraft overruns and undershoots for runway safety areas proposing the ACRP hazard probability model. In the present study the model was integrated into a two-step Monte Carlo simulation procedure to assess the risk of overrun accidents and to provide a topological risk map for a specific airport area. The model was modified to utilize traffic-related and weather-related factors described by statistical distributions of historical data of the airport under analysis. The probability distribution of overrun events was then combined with the Longitudinal and Lateral Location models [1] to obtain a two-dimensional grid assessing the probability of each area to be the end point of a runway overrun. The expected kinetic energy of the aircraft in a given point of the grid is used as severity index. The procedure is suitable for generalisation and it allows a more detailed planning of Airport Safety Areas (ASA), improving the correct implementation of ICAO recommendations. Results are also useful for land planning and structural analyses in airport areas.

Keywords: Runway Excursions; Overruns; Risk Analysis (RA); Monte Carlo methods; Topological Risk Mapping.

1 INTRODUCTION

Operations in the airport field are subjected to a number of different risks, both due to human action and to the intrinsic nature of the manoeuvres themselves. These events may have various characteristics and cover a wide range of events such as collisions between aircraft travelling on taxiways, terrorist strikes, bird strikes, undershoots and many others. This study focuses on runway related accidents and in particular on landing and takeoff overruns. Runway-related accidents represent a relevant fraction of the total number of recorded accidents leading to substantial damage: according to an investigation carried out by the Flight Safety Foundation and based on a data pool collected worldwide from 1995 to 2008, 30% of the total number of accidents belong to the “runway related” category [2]. In particular, 97% of these are overruns. A runway overrun is an event where the aircraft running off the end or the side of the runway exceeding the runway limits during flight operation. This case can happen in three possible scenarios: landing overrun, takeoff overrun and landing undershoot. While undershoots affect the approach and landing phases of the flight, when it may happen that the aircraft touches the ground in a point before the beginning of the runway, overrun events may happen either during landing or during takeoff operations if the aircraft fails to come to a stop within the runway boundaries. Scenarios are reported in the statistical summary of commercial jet airline accidents for worldwide operations from 1959 to 2013 compiled by Boeing [3], a further analysis of 35 years of landing overrun accidents is discussed in the report compiled by Van Es [4]. Along those lines useful information is also to be found in a detailed analysis of an aircraft accident model for Taiwan performed by Shao et al in 2009 [5]. The scenarios selected for the present study considering also the high number of observed occurrences, are those in which the aircraft departs from the runway following a longitudinal direction, therefore crossing its end [6].

Thanks to safety management practices it is possible to locate and estimate risks related to the different accident events, evaluate potential countermeasures and consequently plan the best allocation of resources to reduce risk while maximizing productivity. In particular, the International Civil Aviation Organization [7] issued regulations and procedures for the installation of structures with the aim of preventing and mitigating consequences of such events: despite containing useful guidelines for aerodrome design, they still lack the necessary topological contextualisation and thus may result in very different safety levels depending on the aerodrome characteristics. This leads to the need for a procedure able to evaluate the risk associated with overrun accidents, taking into account the specific

characteristics of the airport under analysis, in terms of layout and operations, with the aim of identifying specific local critical situations.

The objective of the study is to develop and test a probabilistic model able to topologically characterize the risk of aircraft overruns in airports taking into consideration a wide set of uncertain factors, both traffic related and weather related. Starting from existing accident probability models, a Probabilistic Risk Analysis (PRA) procedure is proposed for the assessment of the risk level for infrastructure, buildings and generally obstacles surrounding the airport area, through the definition of a risk map to be superimposed on the airport layout. This will be useful for the identification of the most critical locations and infrastructure in the area, and subsequently for the definition of effective risk mitigation strategies and emergency plans.

The paper starts from a preliminary study already published in [8] and extends the theoretical and methodological background as well as the analysis of results. The paper is organised as follows: in the next section the overall proposed probabilistic approach to runway excursion risk analysis is described and justified in relation to existing contributions in the scientific literature. Section 3 provides an overview of the state of the art on aircraft overrun probability models and describes the selected reference model adopted in the proposed PRA procedure. Section 4 describes the reference deceleration model, while Section 5 is devoted to the detailed description of the proposed two-step PRA procedure able to return a topological risk mapping of the airport layout. Section 6 describes the consequence model by introducing the concept of iso-Kinetic Energy Areas (KEA) as the main severity index. Finally, Section 7 reports the test case application, whereas conclusions and further research opportunities are drawn in the Conclusion section.

2 A PROBABILISTIC APPROACH TO RUNWAY OVERRUN RISK ANALYSIS

While the risk of an aircraft overrunning a runway depends on many factors, like for instance the aircraft weight, weather conditions, presence of contamination on runway surface and many others, in safety regulations and airport operations it is very hard to keep track of all these contributions. Only very generic indexes are widely considered: ICAO recommendations in Annex 14 give very broad directions, in which the aircraft reference field length is the only discriminating variable [7].

Indeed, the problem of developing a customized and consistent risk evaluation methodology on which safety management actions can be based is therefore not a new topic; current models [1] often take a number of factors into consideration to estimate the probability of a certain operation to end up in an overrun incident.

In a study published in 2008 by Hall, Wong, & Ayres titled ACRP (Airport Cooperative Research Program) the authors performed an analysis of aircraft overruns and undershoots for runway safety areas [1]. An accident probability model was then used in combination with a location model, which in turn gives a cumulative probability distribution of the overrunning aircraft to end up its run at a certain distance from the runway end; through the use of both of these models it is possible to assign a probability and a severity value to every considered operation, but it is not possible to characterize the entire airport. This method is very useful when one wants to rank a set of operations by their risk coefficients, which allows to spot critical ones and help deciding where intervention is needed and where resources should be concentrated.

The method discussed in this paper is based on the ACRP model. Unlike former models the ACRP hazard probability model [1] uses normal operational data along with accident data: this allows quantifying the importance of every factor and the way it influences the final accident probability. The model is reported in the form of a logistic regression, and takes into account many different factors both from the traffic and weather conditions point of view, for a total of fourteen and eleven regression parameters for landing and takeoff overruns respectively. The logistic regression technique was chosen because it was deemed suitable to model phenomena with a dichotomous outcome like incident or non-incident, and to take into account a high number of variables including a mixture of continuous and categorical parameters. This kind of approach does not only take into account the particular conditions of one single operation, but allows to describe in a statistical way the traffic and weather conditions a particular runway undergoes throughout the year, thus making possible to obtain a more general result which is valid for all operations carried out on the runway in a specific time window.

Once a “portrait” of the considered runway is obtained, which is independent from any of its particular operations, it is possible to associate it with a distribution, which points out the probability of having a takeoff or landing overrun for that runway. Furthermore, by integrating the location model it is also possible to characterize each point beyond the runway end with the probability distribution of the aircraft kinetic energy, measuring the intensity of the potential impact with an obstacle located in the same point of the grid.

The final step of the proposed methodology is to match these two results – overrun probability and kinetic energy probability for each point of the grid – to assign every point of the terrain surrounding the runway a probability distribution of the expected aircraft kinetic energy for a single movement; since kinetic energy is an index of the damage occurring to possible obstacles in case of crash, the final result is a risk grid around the airport, which can be superimposed on a map of the airport area in order to assign each building a risk value. This is particularly useful in the case of airports close to large and critical infrastructure, generally lacking space for increasing safety areas.

3 OVERRUN PROBABILITY MODELS

3.1 *Literature review and selection of reference models*

In order to assess risk values, tools were needed to assign probability values associated with overrun accidents, as well as models able to estimate consequences of such events. A literature review revealed that several accident probability models have been published in the last decade, starting from Eddowes and Handcox [9], in a report produced by the Norwegian Civil Aviation Authority concerning risk analysis in support of aerodrome design rules. I was followed by Kirkland et al. [10] with studies on data collection and normalization that led to development of models allowing the estimation of probability, location of wreckage and an assessment of the consequences. The models performance was measured with Hosmer-Lemeshow coefficients: for landing models, when using excess distance available as input, it accounts for 11% of the determinants of overrun. If fed with weight-related data the model explains 2.4% and 4.8% of landing and takeoff overrun occurrences respectively. These models had a major limitation as data was only collected for overrun accidents and not for normal operation data (due to the lack of availability of the latter): this led to the impossibility to demonstrate that possible influencing variables have higher frequency in correspondence to incidents than in correspondence of non overrunning flights.

In 2008 the ACRP report “Analysis of Aircraft Overruns and Undershoots for Runway Safety Areas” was published [1]: it faced the problem of assessing overrun probability values for landing and takeoff operations in a more accurate way, accounting for several causal factors and using a model based on a large database of normal operations and accident data. In 2009 Wong et al. proposed a further development of the model. They added a frequency model based on specific accident types in

addition to the building of a single comprehensive database of all relevant accident types. They also tried to consider where in relation to the runway these accidents are likely to occur, but it was mainly based on cumulative previous accident frequencies for different scenarios without actually modelling kinetic energy during landing or take off, i.e. knowing the frequency of accident occurrence are of limited use, and their conclusions are less general, as they used only data collected in the United States [11]. A more detailed description of the ACRP model used is offered in section 3.2.

In Table 1 the main characteristics of the most important overrun accident probability models reported in the literature are briefly summarised. Based on a literature review of prior models, we decided to employ the ACRP hazard probability model. It was preferred to the others mainly due to the large amount of data upon which it is built, coming from civil aviation operations in countries having accident rates comparable to the U.S. In contrast with former models it shows a great improvement by using normal operation data: this allows quantifying the importance of every factor and the way it influences the final accident probability. The model is a logistic regression, and it takes into account many different factors both from the point of view of traffic characterization and exposition of the runway to weather conditions, for a total of fourteen and eleven regression parameters for landing and takeoff overrun respectively; none of the previous models were able to consider all these variables, thus allowing such a complete and deep characterization of the site object of the study. The drawback of such a strong dependence upon data records able to describe the considered circumstance is that some important factors that are part of the actual outcomes of the events could not be considered (e.g. the actual nature of obstacles on the runway path and their impact on reducing the kinetic energy of the aircraft).

Table 1. About here

3.2 *The ACRP Model*

The ACRP model was developed by Hall, et al. in 2008 [1] and was obtained through logistic regression. The model was built using a large number of Normal Operation Data (NOD), which was a great improvement with respect to older models such as the ones used in the studies of Norwegian Civil Aviation in 2001 [9], which only considered accident data. Thanks to the use of NOD, the number of

operations that experienced a particular factor with a benign outcome can be compared to the number of operations where that same factor led to an accident, and therefore the risk factor can be quantified. This allows the understanding of cause-result relationships in takeoff and landing accidents; trends in influential factors can be used to estimate trends in risk levels.

None of the previous models were able to consider all these variables, thus allowing such a complete and deep characterization of the site object of the study. The drawback of such a strong dependence upon data records is that for some important factors consistent data are lacking. Indeed, there is no international standard agreement on the reporting of normal operations or even incidents information. The ACRP model is composed of three modules: Accident Probability model, Longitudinal Location model and Lateral Location Model.

3.2.1 Accident Probability Model

The accident probability model is used to examine accident and incident probability associated with a number of factors, selected by the authors from a mix of weather related and traffic related conditions. The model has the form:

$$P(\text{Accident occurrence}) = \frac{1}{1 + e^{b_0 + b_1 X_1 + b_2 X_2 + \dots}} = \frac{1}{1 + e^b} \quad (1)$$

where $P(\text{Accident occurrence})$ is the probability of occurrence of the considered accident type (landing overrun or takeoff overrun), and coefficient b is determined by the regression analysis including a set of independent variable (X_i). Thus the model is controlled by the sole parameter b , which is a factor used to characterize the type of overrun which depends on the fact that the overrun may have occurred in take off, or landing and considering other factors (e.g. type of aircraft, visibility etc..). The values it can assume are reported in table 2.

Table 2. About here

3.2.2 Longitudinal Location Model

The Location model was developed by Eddowes and Hancox in 2001 [9] and has the same structure for both landing and takeoff overruns:

$$P(\text{Location} > x) = e^{(-ax^a)} \quad (2)$$

where a and n are coefficients depending on the accident type and x is the longitudinal coordinate with origin at the end of the runway and belonging to an axis parallel to the runway centre line. The model returns the probability of the aircraft to end its run beyond the location point addressed by the x coordinate (Figure 1).

Figure 1. About here

Figure 2 shows the values for Landing and Takeoff overrun location probabilities. The graphs refer to raw distances.

Figure 2. About here

3.2.3 *Lateral Location Model*

Besides longitudinal runway excursions, during overrun accidents there is the possibility that the aircraft departs from the lateral boundary of the runway. In a very similar way to the previously illustrated longitudinal model, the lateral location model gives the probability of the plane's final position after an overrun. Figure 3 gives a graphical representation of the cumulative probability for landing and takeoff events respectively.

According to these models, landing overruns final lateral position is characterized by a distribution with a smaller variance than in the case of takeoff overruns.

Figure 3. About here

4 THE DECELERATION MODEL AND THE INITIAL SPEED VALUE.

The deceleration model used in this study is introduced in ACRP report 3 [1] as a tool for data normalization; it was developed by Kirkland et al. in 2003 [10]. It is based on a linear regression and has the following form:

$$a = p + q * u \quad (3)$$

where a is the acceleration in $[m/s^2]$, p is a parameter derived from the regression which accounts for different terrain types according to values shown in Table 3 and u is the initial speed (i.e. runway exit speed) in $[m/s]$. The values currently assigned to this parameter could be extended to take into account obstacles with different frangibility levels, however those values were not considered in the current methodology where the focus was testing the advantages provided by a special application of the kinetic energy theorem as illustrated further in this paragraph. Parameter q $[ms]$ is constant across all the cases. The parameter accounting for the ground type gathers together respectively wet grass with dry grass and pavement, mud and gravel and obstacles and water. Using this model we are therefore able to discriminate only between very generic ground types, which in turn embrace a wide range of possible conditions.

The above-mentioned equation is used along with equation (4), an application of the kinetic energy theorem, which allows the calculation of an average acceleration value given travelled distance and extreme speed values.

$$a = \frac{V^2 - u^2}{2s} \quad (4)$$

Where a is the acceleration, V the final velocity, u the initial velocity and s the distance traveled.

Table 3. About here

The coupling of these two equations allows solving for the initial speed, which is the only unknown term since we assume the final speed to be null in correspondence of the final location (as assumed by the location model) and we keep the traveled distance as an independent parameter (equation (5)).

$$u = -qs + \sqrt{(qs)^2 - 2ps} \quad (5)$$

We are therefore able to associate an initial speed to any possible value of distance covered by the plane before stopping, which means we can also assign a speed to each point along its route given its final location. This relationship is linear.

5 TOPOLOGICAL MODELLING OF THE OVERRUN ACCIDENT PROBABILITY

The objective of the study was to obtain a probability distribution able to describe the accident probability for the whole landing and takeoff traffic of the chosen runway for the all relevant operation conditions.

Figure 4 and Figure 5 illustrate the two-step procedure that uses the Monte Carlo method in order to properly account for the uncertainties in causal factors. The frequency model was therefore fed with discrete probability distribution functions, one for each one of the factors included in the ACRP model. Parameter b was modified in such a way that it could be governed by discrete probability distributions. Equation 6 shows the basic expression, where X_{ij} is the i^{th} level of the j^{th} factor and can only assume values one, if the considered operation was carried out in the particular condition represented by that level, or zero, in all other cases. Equation 5 shows how the expression of parameter b has been modified. Moreover, it would have been necessary to assess a correlation between values belonging to the same category, since the same record cannot fall into two different levels of the same category at the same time.

$$b = a_0 + a_1X_{11} + a_2X_{21} + a_3X_{31} + \dots + a_nX_{nm} \quad (6)$$

$$b = a_0 + [\text{discrete distribution}(a_1, p_1; a_2, p_2; a_3, p_3; \dots)] + \dots + [\text{discrete distribution}(\dots; a_{n-2}, p_{n-2}; a_{n-1}, p_{n-1}; a_n, p_n)] \quad (7)$$

In Equation (7) each factor is described by one discrete distribution, which couples each level i with its probability of occurrence p_i ; it was therefore sufficient for every level to record its frequency of occurrence within the factor, and use the information to build a discrete probability distribution with these values; this has to be done for every factor; finally, distributions obtained are fed into the model. A graphical representation is given in Figure 6 of the distribution for factor “visibility”; it consists in four levels, labeled from one to four. The software chosen to run these calculations was Palisade @Risk.

Figure 4. About here

Figure 5. About here.

Figure 6. About here.

Therefore, it is possible to build a two-dimensional grid that reports the probability of every point to be hit by an accident. Once again, this is done using Monte Carlo simulations: the value we are looking for is the combination of the three different abovementioned probabilities. In order for the point to be hit by an accident, first the accident has to happen, second the plane has to exit the runway fast enough to reach the considered point and finally the crash point has to fall into the lateral range corresponding to the considered location.

The combined probability is therefore the product of these three probabilities, two of which are single values while one is described by a probability density function. The cells of the grid, of arbitrary size, correspond to physical areas, which correspond to the estimated probability of such areas being hit by an overrun accident (Figure 4).

6 SEVERITY INDEX AND ISO-KINETIC ENERGY AREAS (IKEA)

In order to evaluate the consequences of an overrun accident, along with possible casualties and harm to passengers and crewmembers, also direct and indirect costs should be taken into account. Indirect costs, such as loss of revenue, loss of operating time, disruption of flight schedule and reputational loss, are estimated to be four times the amount of direct costs [9] in this type of accident; they are very hard to evaluate, since they depend upon many factors not directly connected with the dynamics of the accident. Direct costs comprise injuries, damage to the aircraft, investigations and third party injuries; while they are not altogether easy to evaluate, their connection with accident dynamics is more intuitive and they also give a good idea about the overall severity of the event.

It is however impossible to make a pinpoint forecast of casualties and direct costs; we therefore focused on property loss, which comprises damage to the aircraft and damage to infrastructure potentially involved in the accident. As common sense suggests, these two elements in the large majority of cases are dependent from the intensity of the impact: this in turn can be quantified by the evaluation of either forces involved or the energy values. To this end, state-of-art approaches involve complex dynamic analysis with three-dimensional finite elements [12][13][14][15][16][17][18]; these approaches require the definition of shapes and materials, and results are not fit for generalization.

As our objective was to characterize every possible critical target in the surroundings of the runway with a risk value, it was not practical to undertake such a detailed and refined work for all the in-

frastructure present in the area. The solution was to substitute cost as a severity parameter with the kinetic energy of the aircraft in the crash. This approach uncouples incident dynamics and target characterization; it is therefore not meant to be quantitative in terms of damage assessment, either from a physical or economical point of view, while it is able to return a criticality index and associated information for a possible detailed local study.

Using the deceleration model, the cumulative probability function of accident location, given by the Location Model, was turned into a cumulative probability function for speed for every location chosen beyond the runway end. We chose these locations so they would match with columns of the two-dimensional grid previously defined, in order to be able to superimpose results later on.

Using the aforementioned described formula the cumulative probability function of accident location, given by the Location Model, was turned into a cumulative probability function for speed. This was easily done by associating each distance with its corresponding initial speed: for instance if we place ourselves on the runway end in $x=0$, we will have a probability equal to 1 for the speed to be greater than zero, given the overrun occurrence; the Location model then gives for example a probability value of 0.1 that the aircraft will travel a distance of 245 meters or beyond; according to the deceleration model, the airplane has to exit the runway with a speed of at least 120 Kilometers per hour in order to reach that distance. We can therefore assert that there is a probability of 0.1 that during a landing overrun accident the aircraft has a speed equal or superior to 120 Km/h.

The reasoning is repeated for all the points and a cumulative probability function is drawn, which is then converted into a probability distribution function. The result is only an approximation since the cumulative probability function previously obtained is known only by points and not by the algebraic formula; the derivative is therefore replaced with a finite incremental ratio. This however should not jeopardize the validity of results since the resolution is pretty high, there being one calculated value every 5 meters in a context where interesting distances are of the order of hundreds of meters.

The procedure is then repeated, moving the observation point to every other distance of interest along the runway axis, with a slight difference: in x -points greater than zero there is not a 100% probability of the aircraft reaching the observation point: the resulting speed distribution is then characterized by a very high probability corresponding to the zero value. For instance, in $x=50$ m we have a probability of 0.625 to record a zero speed, while the remaining 0.375 is spread between all the possible non-zero speed values. This high delta obviously increases as the observation point is located farther from

the runway end and the probability of recording a null velocity in case of accident increases accordingly, with the effect of making graphical results very difficult to understand.

In order to solve this problem the speed distribution is calculated by excluding the null value, while this information is kept separated and represents the probability that, even in case of an accident, the aircraft does not reach the considered point.

If we move from the runway end and we place ourselves, for instance, in $x=400$ meters, we have a probability of 0.025169 of having a speed greater than zero in case of accident while, given that the accident happened and reached this point, we will record a speed depending from the distribution shown in Figure 7.

Figure 7. About here.

We assigned a speed distribution to every “observation” point beyond the runway end; later these will be able to combine with the weight distribution characterizing the traffic of the airport under analysis. In this study we considered a range of 1000 meters, and calculations were made for every 50 meters for a total of 20 considered points along the runway axis (Figure 8).

It is worth noting that the trend of expected speed does not evolve with distance from the runway end in a very intuitive way: one would expect speed expected values to simply decrease as it gets farther from the runway end. It is not so, at least for what concerns landing overruns: in the first 1000 meters the percentage of “high speed” aircraft increases with the distance from runway end, causing a positive trend to be recorded for average speeds.

Landing overrun expected speeds have a marked growing trend in the first 700 m, then assuming an almost constant value that decreases very rapidly after the 1000 m threshold.

Takeoff overruns as expected have higher mean speeds. Their course decreases monotonously: a rapid decrease is visible in the first hundred meters, followed by a relatively constant range between 500

m and 1000 m where the average speed is comprised between 80 Km/h and 90 Km/h; a sudden drop follows and the function overlaps with the one referring to landing overruns.

Figure 8. About here

A probability distribution describing the mass of aircrafts doing landing or takeoff operations in the considered airport can be easily built referring to historical records (in the present study calculations were carried out separately for landing and takeoff, due to the difference in the location models and mass distributions). By using Monte Carlo simulation, it is then possible to combine speed values from probability distributions with mass values, obtaining a probability distribution of kinetic energy values for every location, given the accident. Figure 9 shows the mean value trend resulting from the Monte Carlo simulations.

Figure 9. About here

A further application of the Monte Carlo technique allows the combination of probability values of accidents specific to each location (as given by the two-dimensional grid previously obtained) with corresponding values from kinetic energy probability distributions. The result is a two-dimensional grid, which can be superimposed on the airport topological map, expressing for each area the expected kinetic energy distribution due to overrun events, named Iso-Kinetic Energy Areas (IKEA, expressed in [kJ/movement]).

7 CASE STUDY: OVERRUN RISK ANALYSIS AT LINATE AIRPORT (MILAN, ITALY)

7.1 Input data pre-processing

The complete procedure was applied to Enrico Forlanini Airport (LIN), the second larger civil airport serving the Milan metropolitan area after Malpensa.

To carry out the study, we used data referring to the year 2009. Airport Traffic data was available from the database “Business Objects” of SEA, the Milan airports management company. It consisted in about 40500 records, each one containing information about a single operation, either an arrival or a departure, date of the flights, aircraft model, national or international origin or destination, user category (such as passenger, freighter, mail etc.), aircraft dimensions and mass expressed by Maximum Takeoff Weight (MTOW), and the number of movements corresponding to the description given by the previous columns.

Meteorological data was available thanks to the Ente Nazionale di Assistenza al Volo (ENAV) as a collection of reports sampled every thirty minutes. The reports come in METAR (METeorological Aerodrome Report) format, one of the most popular formats in the world for the transmission of weather data. It is highly standardized through International Civil Aviation Organization (ICAO), which allows it to be understood throughout most of the globe. METAR records consist on a row of letters and numbers grouped so as to form codes. A typical METAR report contains data for temperature, dew point, wind speed and direction, precipitation, cloud cover and height, visibility, and barometric pressure. A METAR report may also contain information on precipitation amounts, lightning, and other information that would be of interest to pilots or meteorologists.

Based on the mentioned data sets, discrete probability distributions were built according to the observed frequency of levels for each factor; these in turn have been used as inputs for the comprehensive model, as previously explained.

Seasonality phenomena have been checked by means of Friedman test, for continuous and categorical data (such as “Temperature” and “User Class” respectively), and of chi-square test, for Boolean data (such as the presence of rain and thunderstorms). Due to the high seasonality shown especially by weather-related data, the procedure was executed separately for each season. Figure 10 and Figure 11 provide an outlook on some of the most relevant input data.

Figure 10. About here

Figure 11. About here

In the application of Monte Carlo method values corresponding to the various factors are extracted depending on the correspondent probability distributions; when the software user doesn't specify any relationship between them, the simulation goes on with the assumption that the above-mentioned factors are completely independent from one another. In our case however it looked more than likely that some of the factors values could influence the way in which other values make their appearance; for instance, if a very low temperature value is extracted the scenario is more likely to be snowy than it would have been if an high temperature value appeared. In order to keep these bounds into account, Pearson correlation coefficients were determined for each combination of factors; they can be seen for each pair of factors, reported in Table 4.

Table 4. About here.

7.2 Analysis and Topological reporting of Results

In the following some of the most interesting results are reported and briefly discussed. Nevertheless, due to the confidentiality and proprietary nature of the data some references and details are omitted.

Results, which may be expressed in the form of two-dimensional grids, include accident probability per movement, return time of an overrun accident and expected aircraft kinetic energy per movement. While the local values of different indicators depend on the resolution chosen for the grid, Figure 12 and Figure 13 give an overview on the gradients followed by return times and expected kinetic energy respectively. High kinetic energy values per movement and short expected times are assigned the color red: the decreasing level of concern is clearly visible when increasing the distance between the observation point and the runway end, and it was highlighted by gradually shading toward green and blue respectively.

The most critical points are obviously located right beyond the runway end: in this location we obtained return times of the order of ten years and expected kinetic energy values of 10^{-2} kJ/movement. It is difficult to compare these results with recorded data in order to assess the accuracy of the model, since such a short excursion would not necessarily be considered an accident, thanks also to the presence of the runway safety area, the data about such minor occurrences might not have been always recorded.

Figure 12. About here

Figure 13. About here

A sensitivity analysis was also carried out: factors were controlled, one by one, during multiple simulations, so that it was possible to assess their degree of influence on accident probability. The tornado

graph is a particularly direct way to represent sensitivity results: it shows the variation of the mean value of the accident probability that a percentage variation of every factor is able to induce. Tornado graphs in Figure 14 and Figure 15 refer to landings and takeoff overrun probabilities respectively, and have been calculated using winter data (the worst scenario). Weather-related data are clearly the most influential factors; the presence of icing conditions, snow and crosswind are the factors which most contribute in increasing accident probability. The only significant traffic-related factor is equipment class, which is however influential during takeoff operations only.

Figure 14. About here

Figure 15. About here

8 CONCLUSIONS AND POSSIBLE FURTHER DEVELOPMENTS

While previous models gave single probability values as output, the proposed two-steps procedure returns probability and severity results in the form of a topological grid, thus characterising the terrain surrounding the runway and therefore giving the possibility to compare them with the underlying infrastructure. Results are available in several forms, starting from the simple probability distribution of each area to be hit by an overrun, to the expected kinetic energy received in case of accident or the combination of both into a risk index.

The method proposed is a more systematic approach to quantify risk levels at individual runway ends, which form the basis for determining appropriate ASA dimensions. The proposed technique also has the advantage of being relatively transparent and more independent from qualitative judgements that are predominant even in modern cost benefit evaluation of safety programs.[19]

From a meteorological point of view the model allows a detailed characterisation, not only of the area surrounding the airport but also of the chosen runway where the analysis is being conducted: in fact, in large airports, some meteorological or topological factors, such as crosswind speed or type of terrain, may differ from one runway to another. The model also takes into consideration the type of traffic the runway is subject to: aircraft movements are assigned a weight class, propulsion type, user class and type of origin or destination, discriminated between local and foreign. A further characterization of the airport involves the possible presence of significant terrain in its proximities and the distinction between hub or non hub, depending on traffic amount. All this information is able to describe the airport traffic and environment in an extremely detailed way over any chosen period.

Results provided by the proposed procedure are primarily relevant for safety management, land planning and structural analysis of airport facilities. However, airline companies might also benefit from such a way of studying and characterising their points of departure and destination in terms of overrun risks; indeed, also airline companies have some options at hand to mitigate overrun risks, e.g. by an advanced planning of fleet and crews according to the seasonal variation of risk exposure at different departure and destination airports.

A summary of the implications of the study for runway design or operation is listed below:

- The method allows a better quantification of the probability of accidents for each topological area of the airport allowing a more detailed planning of Airport Safety Areas (ASA). The ICAO may have implicitly considered in its safety regulations for airport operations however as already mentioned the recommendations provided in Annex 14 are only able to give very broad directions, while the current method allows an explicit quantification of the diverse influences of risk and facilitates the assessment of expected accident frequencies and expected kinetic energy in different locations. ASA dimensional needs could therefore be adjusted with consideration for both criteria.
- The present study also offers some relevant insight on the dynamics of overrun events and the effects in terms of expected consequences from the airport layout point of view, as it demonstrated that, despite the rapid decrease of the probability that an aircraft will overrun a long distance, the expected speed during a runway excursion remains almost constant for about 1,000 m beyond the runway end (as per the results visualized in Figure 8 and Figure 9); the same is valid for the associated kinetic energy of the aircraft. This result therefore is to be used to test the need to design physical protective measures and better layouts in modern airports.

- Further development of the models may also allow taking into account the possibility of comparing different methods to absorb the expected kinetic energies of overruns so as to minimize damage.

The proposed approach and procedure still suffers from some limitations; directions for further improvements clearly emerged during their development and first implementation; they also correspond to areas of ongoing research:

- continuous improvement of probability and location models to include a wider spectrum of influencing factors, particularly the available excess runway [20];
- also the deceleration model, proposed by Kirkland et al. [10] and adopted in the proposed PRA procedure, could be enhanced to remove the limits of a linear approximation and to account for a wider set of terrain and obstacle types;
- the consequence model could also be enlarged and improved [20], to integrate some basic vulnerability assessment methods of infrastructure and buildings and also to enable the assessment of more complex accident scenarios (e.g. an overrun event ending with fire or explosion).
- Finally the model currently proposed is based on modules that have already been statistically validated by comparing the results of the regressions with the actual statistical accident data collected [1]. However, a further validation of the results obtained by the study (especially in relation to the kinetic energy element) could be obtained if data from Advanced Surface Movement Guidance and Control System (A-SMGCS) [21] could be stored and used for this purpose.

Further developments of this kind are to be negotiated with the airport authorities and if successful, there is considerable scope to develop more extensive case studies.

REFERENCES

- [1] Hall J, Wong D, Ayres M. Analysis of Aircraft Overruns and Undershoots for Runway Safety Areas. Airport Cooperative Research Program. Washington DC: Transportation Research Board; 2008
- [2] Flight Safety Foundation. Reducing the Risk of Runway Excursions. Flight Safety Foundation; 2009.
- [3] Boeing Company. Statistical Summary of Commercial Jets Airline Accidents: Worldwide Operations 1959-2013. Chicago: Boeing Company; August 2014. available on line at <http://www.boeing.com/aboutus/govt-ops/reports-white-papers/commercial-Sjet-airplane-accidents-statistical-summary.pdf>

- [4] Van Es GWH. Running out of Runways: Analysis of 35 Years of Landing Overrun Accidents Publication NLRTP-2005-498. Amsterdam: National Aerospace Laboratories; 2005.
- [5] Shao P-C, Chang Y-H, Chen HJ. Analysis of an aircraft accident model in Taiwan. *Journal of Air Transport Management*. 2010; 27: 34-38
- [6] Pasindu HR, Fwa TF, Ong GP. Computation of aircraft braking distances. *Transportation Research Record* 2011; 2214: 126-135.
- [7] ICAO. Convention on International Civil Aviation - Annex 14: Aerodromes - Aerodrome Design and Operations. Vol. 1. 6th Edition. ICAO; 2013.
- [8] Gratton MG, De Ambroggi M, Trucco P. Probabilistic Risk Analysis procedure for aircraft overruns. *Advances in Safety, Reliability and Risk Management - Proceedings of the European Safety and Reliability Conference*. ESREL 2011; 2012, p. 1376-1383.
- [9] Eddowes M, Hancox J, MacInnes A.. Final Report On The Risk Analysis In Support Of Aerodrome Design Rules - A Report produced for the Norwegian Civil Aviation Authority. UK: AEA Technology; 2001.
- [10] Kirkland I, Caves RE, Hirst M, Pitfield DE. The normalisation of aircraft overrun accident data. *Journal of Air Transport Management* 2003; 9: 333-341.
- [11] Wong DKY, Pitfield DE, Caves RE, Appleyard AJ. The development of a more risk-sensitive and flexible airport safety area strategy: Part I. The development of an improved accident frequency model. *Safety Science* 2009; 47: 903-912.
- [12] Henkel F-H, Klein D. Variants of Analysis of the Load Case Airplane Crash. *Proceedings of SMiRT 19*, paper J03-2. August 12-17, 2007. Toronto, Canada.
- [13] Mult E, Eibl J. Airplane Impact on Nuclear Power Plants. *Conference on Structural Mechanics in Reactor Technology*. 2003. Prague, Czech Republic.
- [14] Koechlin P, Potapov S. Classification of soft and hard impacts, Application to aircraft crash. *Nuclear Engineering and Design* 2009; 239 (4): 613-618.
- [15] DOE. Accident Analysis for Aircraft Crash into Hazardous Facilities. DOE Standard. Washington DC: Department of Energy; 2006.
- [16] Sugano T, Tsubota H, Kasai Y, Koshika N, Orui S, von Riesemann WA, Bickel DC, Parks MB. Full-scale aircraft impact test for evaluation of impact forces. *Nuclear Engineering and Design* 1993; 140: 373-385.
- [17] Chang WS. Impact of Solid Missiles on Concrete Barriers. *J. of the Structural Division* 1981; 107: 257-271.
- [18] Riera J. On the Stress Analysis of Structures Subjected to Aircraft Impact Forces. *Nuclear Engineering and Design* 1968; 8: 415-426.

- [19] Rogerson E C. & Lambert J.H. (2012) Prioritizing risks via several expert perspectives with application to runway safety. *Reliability Engineering and System Safety* 103, 22–34.
- [20] Ayres MJr, Shirazi H, Carvalho R, Hall J, Speir R, Arambula E, David R, Gadzinski J, Caves R, Wong D, Pitfield D. Modelling the location and consequences of aircraft accidents. *Safety Science* 2013; 51: 178–186.
- [21] ICAO 2004 - Manual Of Advanced Surface Movement Guidance And Control Systems, DOC 9830.

Accepted manuscript

FIGURES

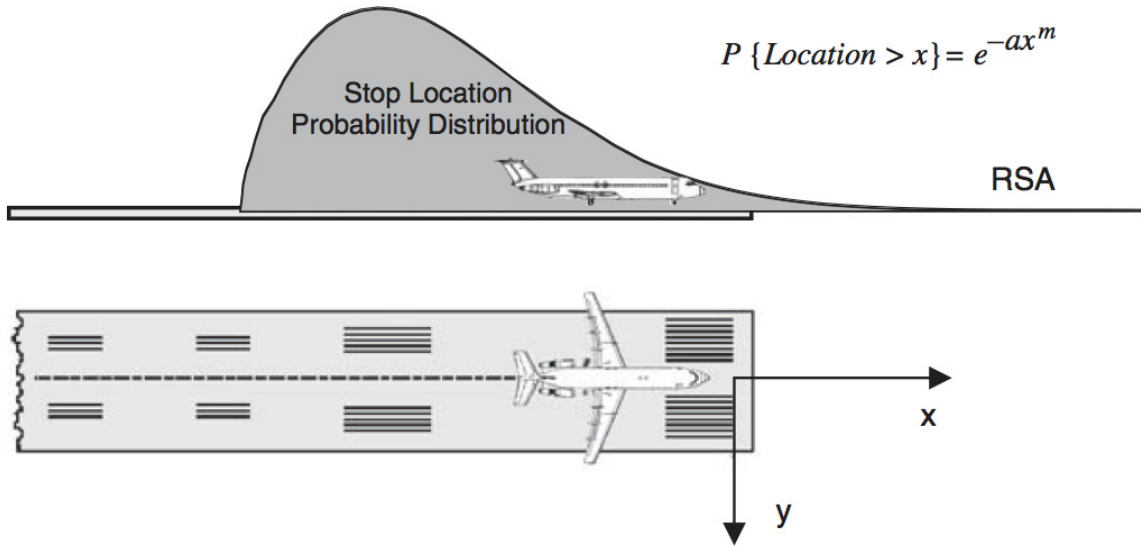

Figure 16. Reference scheme for the FAA ACRP Longitudinal and Lateral Models [6]. RSA = Runway Safety Area.

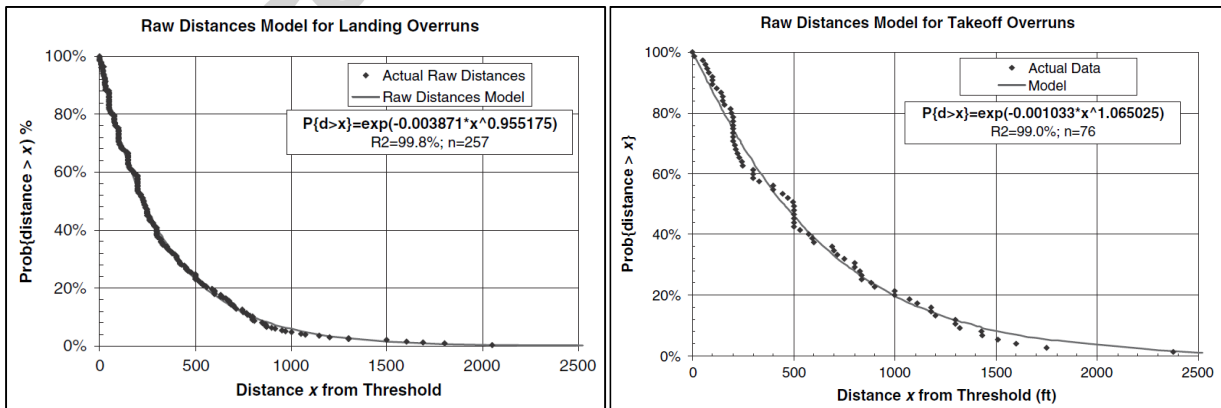

Figure 17. Longitudinal Location Model for Landing and Takeoff Overtuns [1].

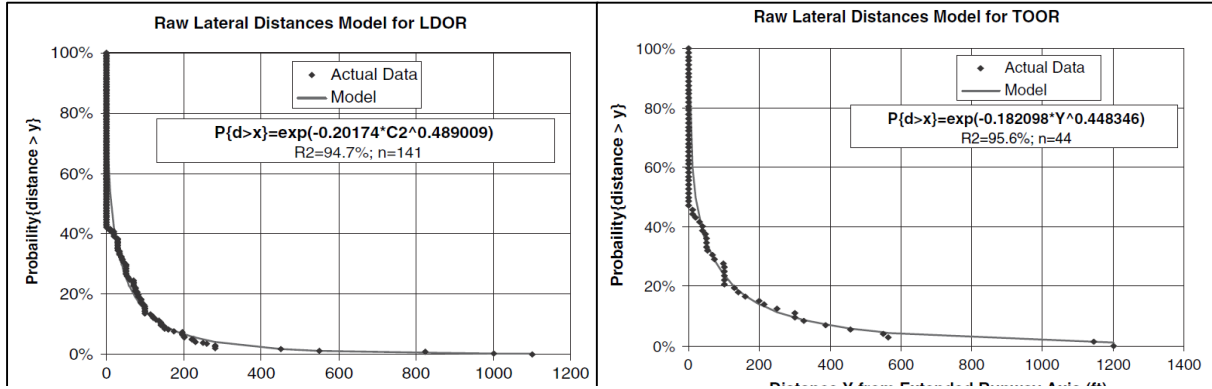

Figure 18. Lateral Location Model for Landing and Takeoff Overruns (LDOR: Landing Overruns; TOOR: Take-off Overruns) [1]

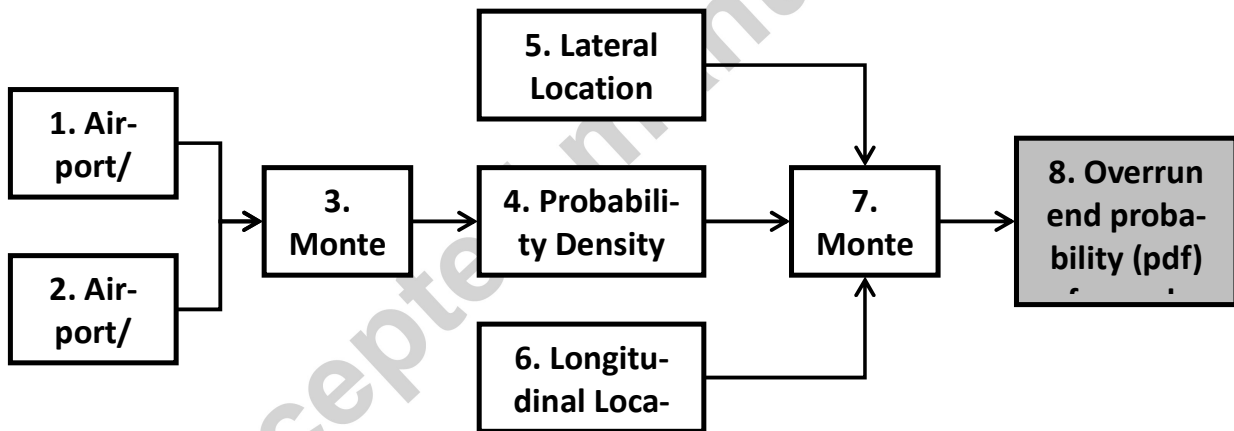

Figure 19. Block diagram of the first part of the procedure, returning the topological grid of overrun location probability (expressed as event/movement).

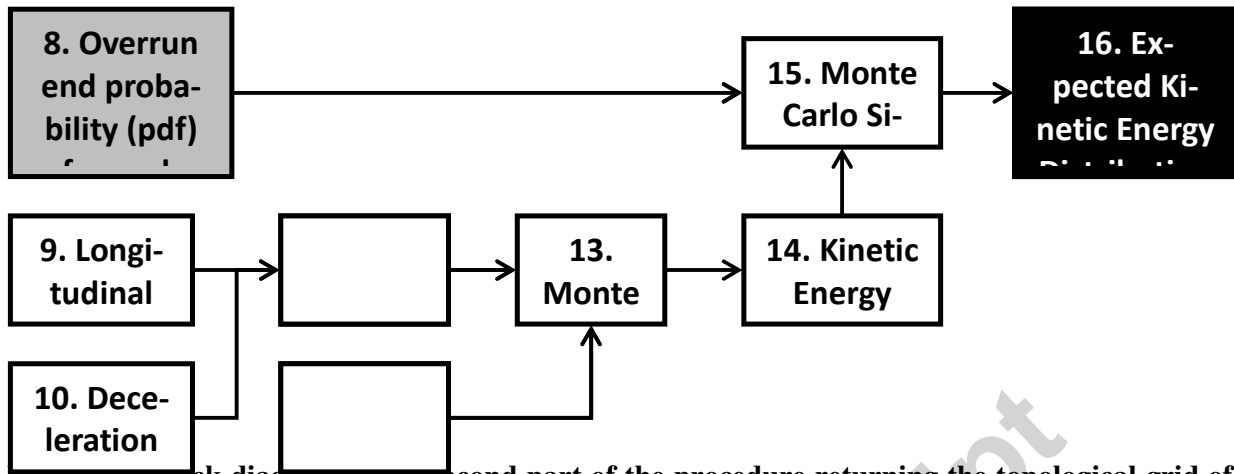

Figure 20. Block diagram of the second part of the procedure returning the topological grid of the expected kinetic energy distribution (KEA, expressed in kJ/movement).

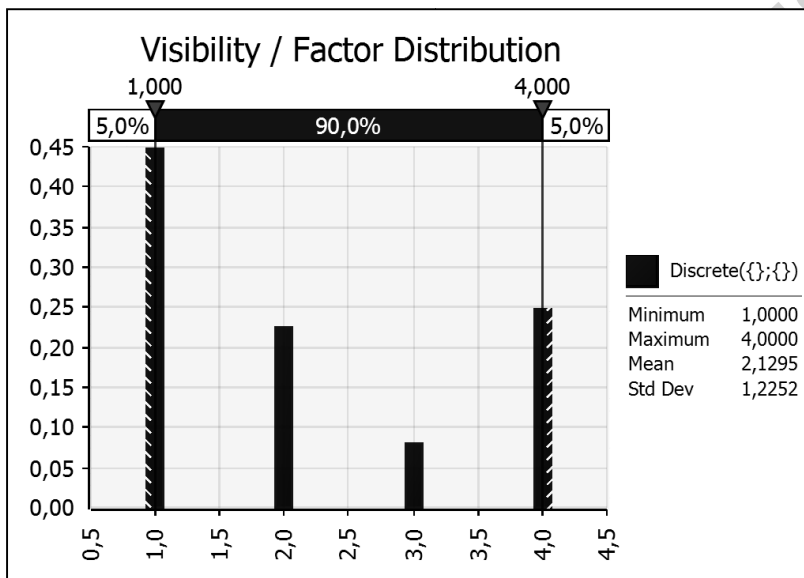

Figure 21. Discrete probability distribution function of the “Visibility” factor in the case test application

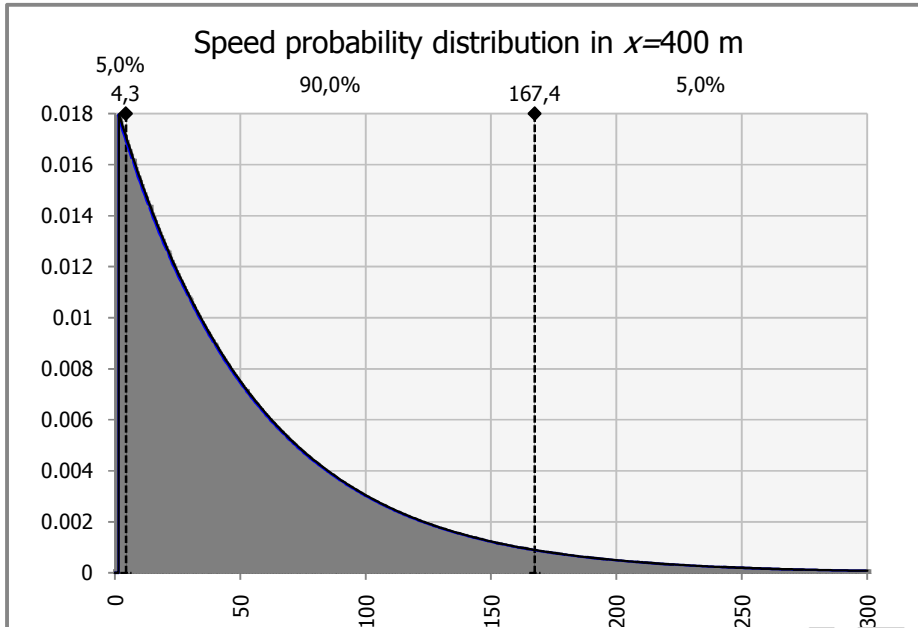

Figure 22. Speed probability distribution in $x=400$ m; speed values are expressed in Kilometers per hour

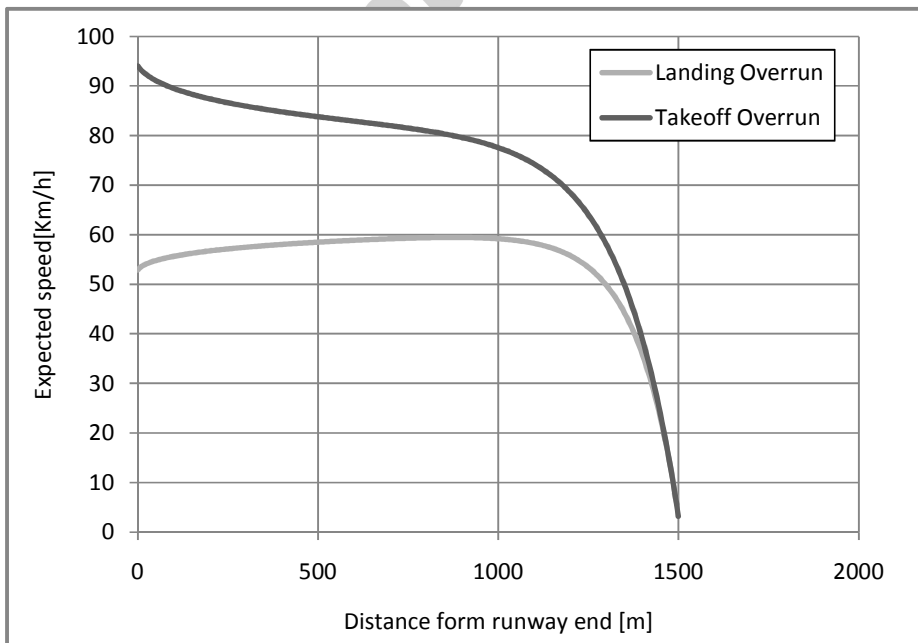

Figure 23. Expected speed trend for Landing and Takeoff overruns versus travelled distance from runway end

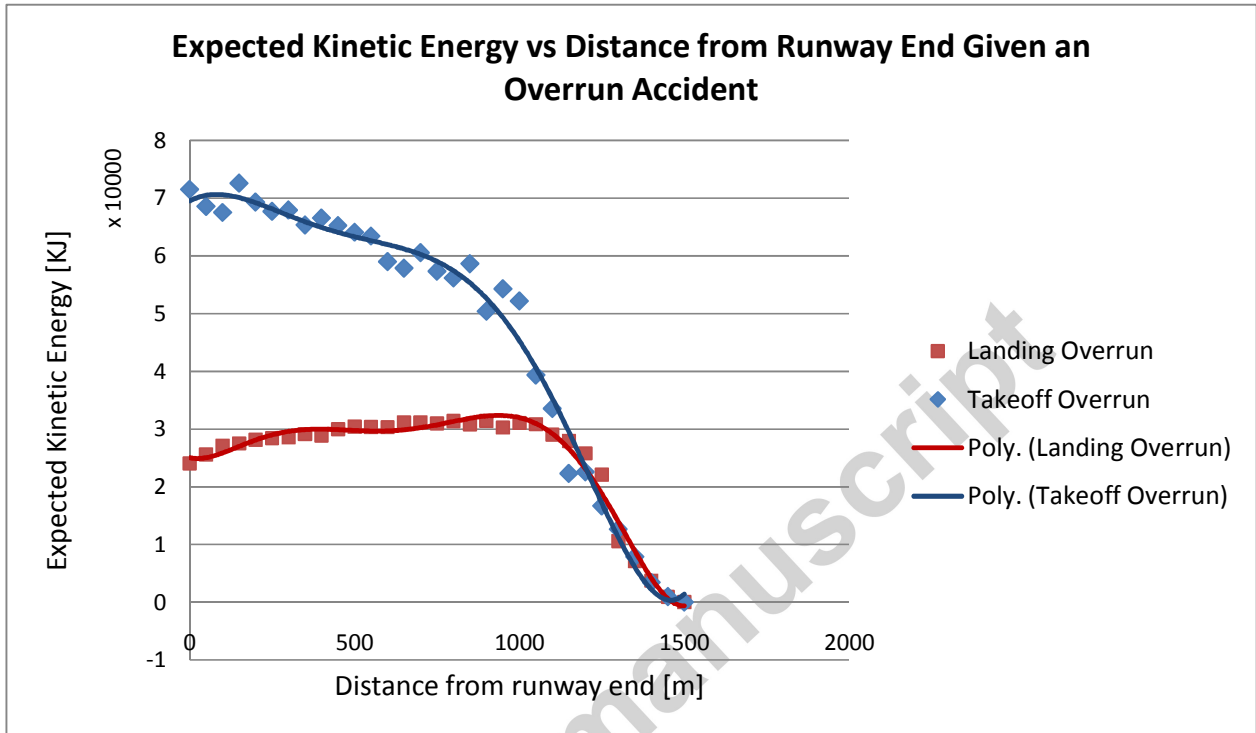

Figure 24. Expected Kinetic Energy as a function of distance from the runway end, given the occurrence of an overrun accident

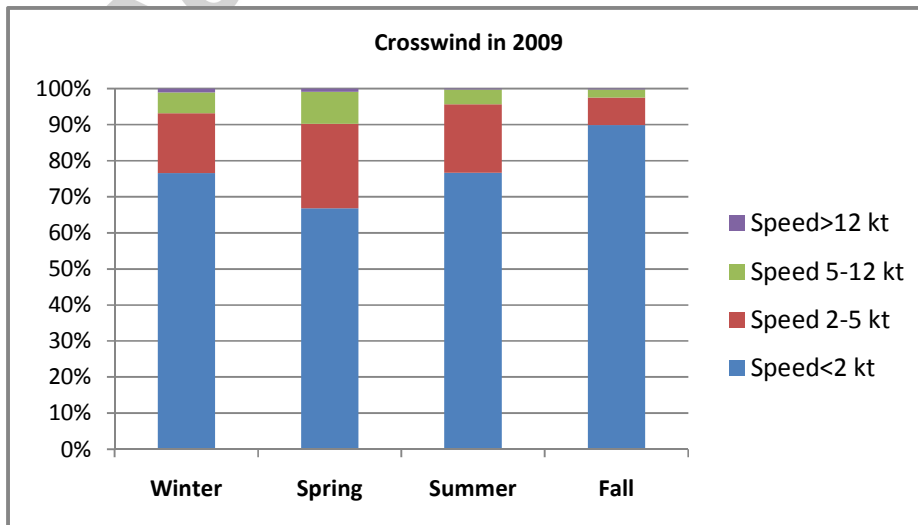

Figure 25. Crosswind intensity at the primary runway of Linate Airport (year 2009)

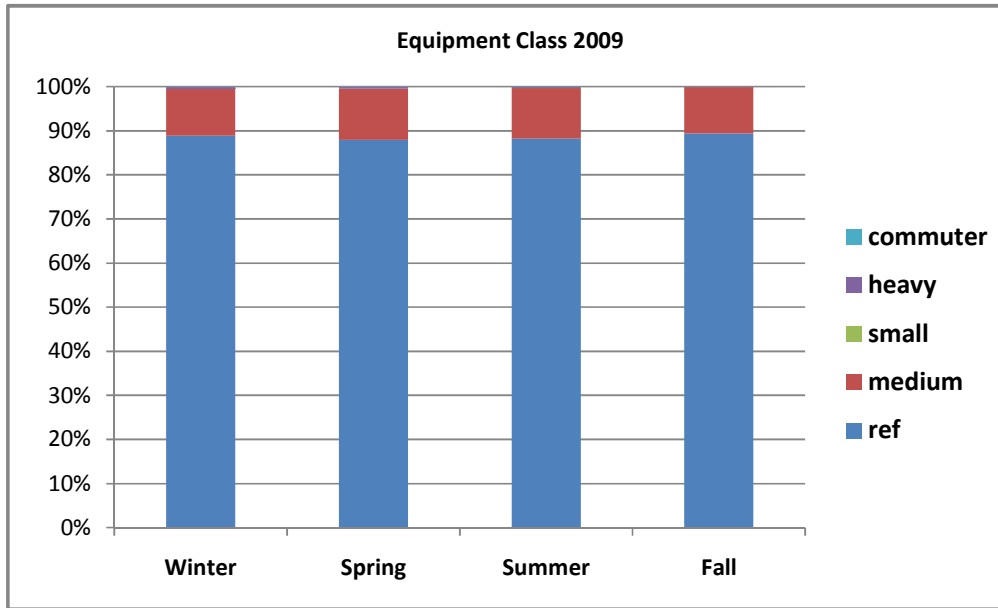

Figure 26. Percentage distribution of equipment class for operations carried out at Linate Airport (year 2009).

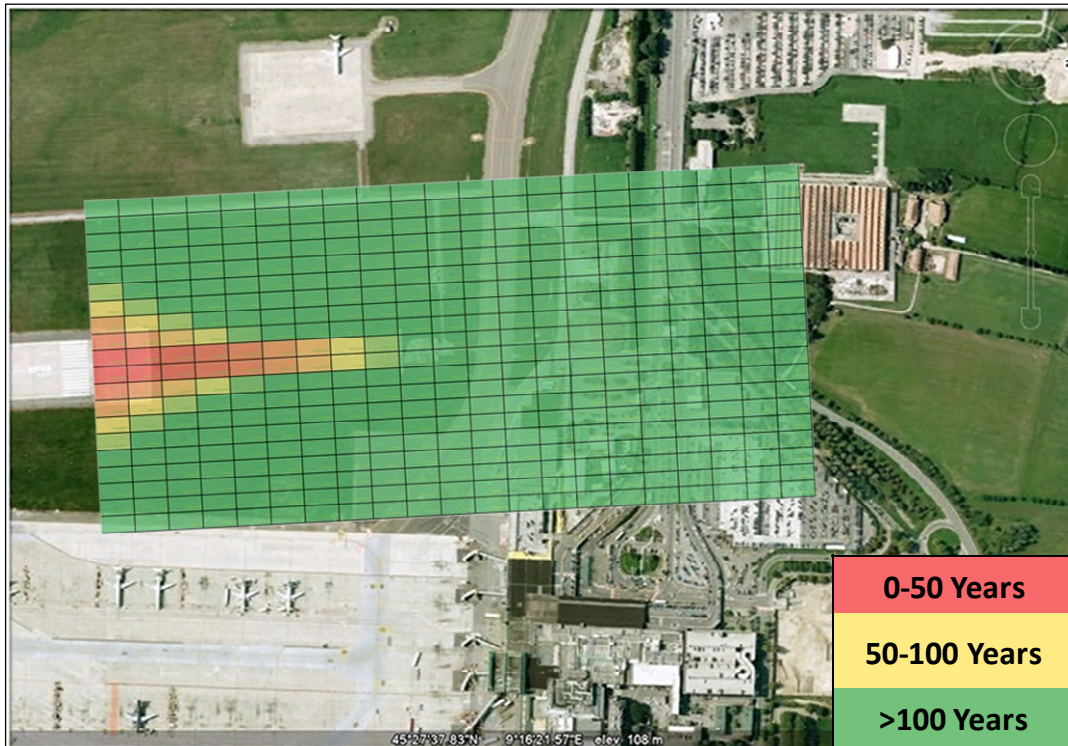

Figure 27. Expected Return Time (expressed in years) grid for Landing overruns (for confidentiality reasons the grid does not represent the real topology).



Figure 28. KEA severity index: expected kinetic energy distribution [kJ/movement] beyond runway end (for confidentiality reasons the grid does not represent the real topology).

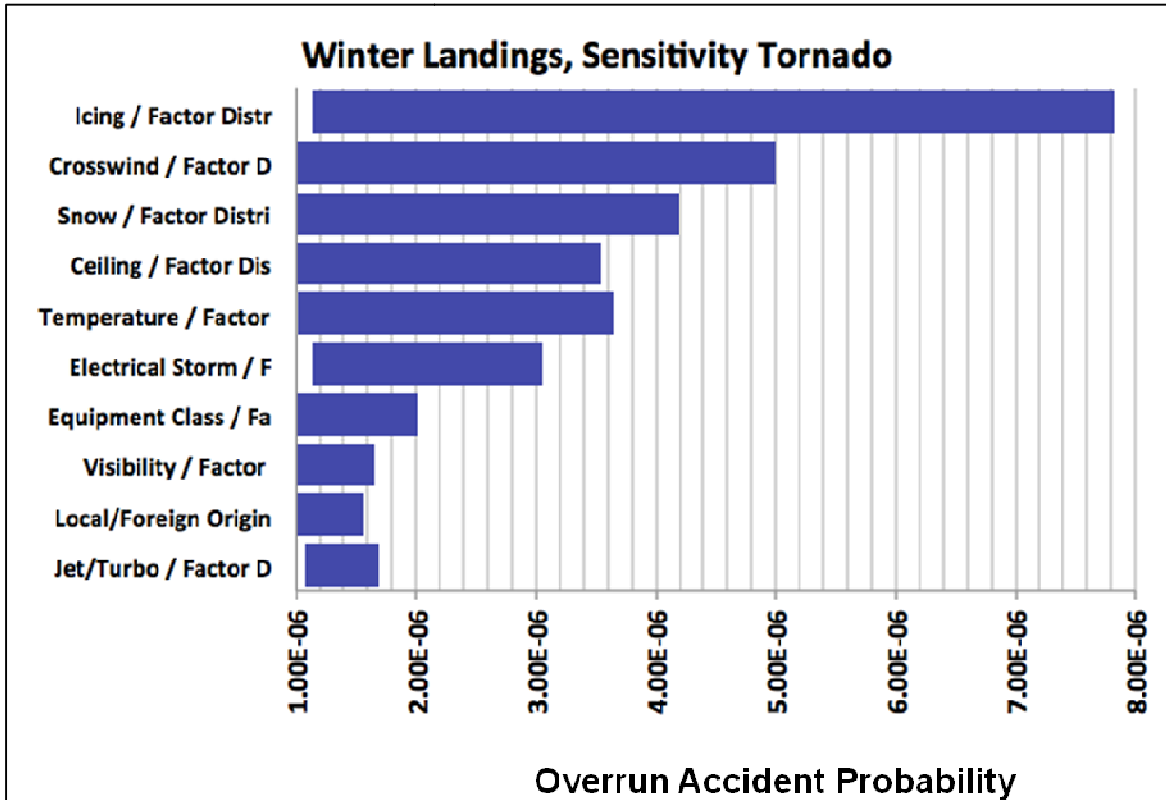

Figure 29. Sensitivity Tornado of the Overrun Mean Probability during winter landings

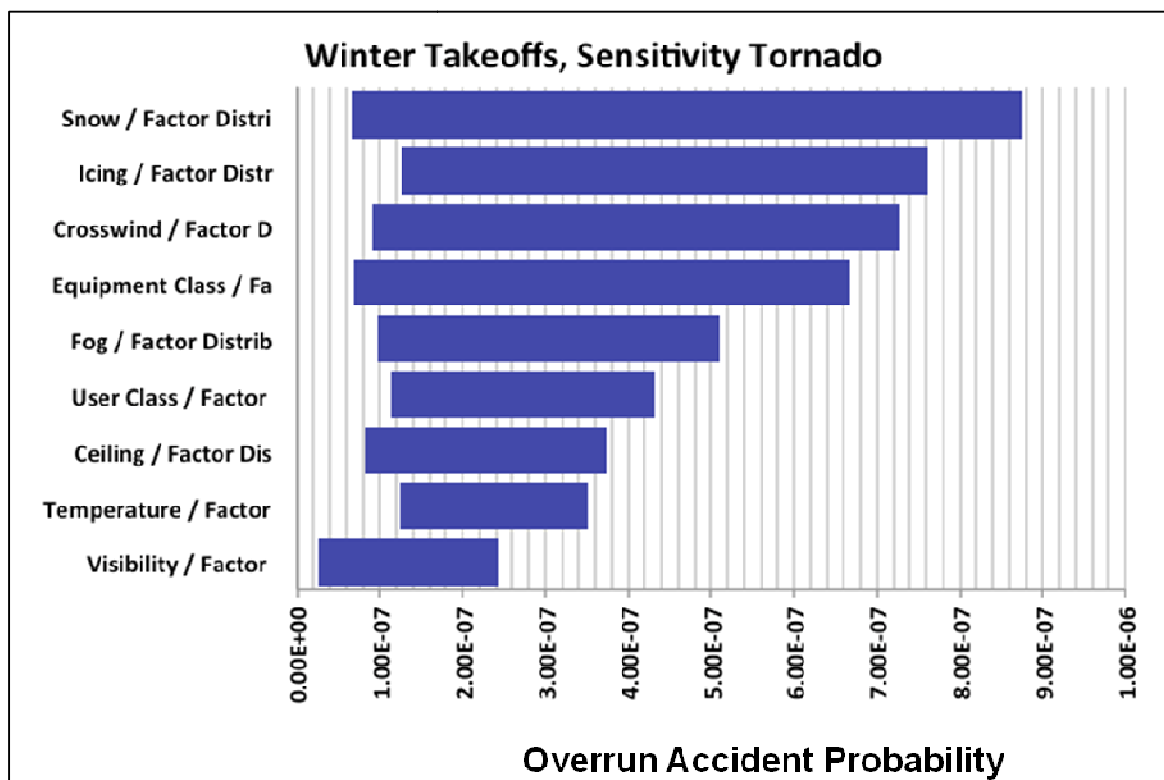

Figure 30. Sensitivity Tornado of the Overrun Mean Probability during winter takeoffs

TABLES

Table 5. Comparison of Overrun Accident models reported in literature

| | Eddowes et al., 2001 [9] | Kirkland et al., 2004 [10] | Hall et al., 2008 [6] | Wong et al., 2009 [11] |
|---|--------------------------|----------------------------|-----------------------|------------------------|
| Number of factors included in the model | 1 | <5 | 14 | 17 |
| Type of input and output data. (D = deterministic; P= probabilistic) | D | D | D | D |
| Is the model based on a collection of international data (incident reports and/or NOD)? | NO | NO | YES | NO |
| Is the model based on Normal Operations Data (NOD)? | NO | NO | YES | YES |

Table 2: Factors used to characterize b in equation (1) for each accident type.

| Factors to be added to b to characterize the type of Takeoff Overrun | Factors to be added to b to characterize the type of Landing Overrun |
|---|---|
| $b(\text{Takeoff Overrun}) = -16.6515$ | $b(\text{Landing Overrun}) = -15.456 +$ |
| +0.721(Heavy aircraft) | +0.551(Heavy aircraft) |
| -0.619(Commuter Aircraft) | -2.113(Commuter Aircraft) |
| -0.009(Medium Aircraft) | -1.064(Medium Aircraft) |
| +1.669(Small Aircraft) | -0.876(Small Aircraft) |
| +1.052(General Aviation) | +0.445(Turboprop Aircraft) |
| +1.225(Ceiling Height<1000 ft) | -0.856(Foreign Origin) |
| +1.497(Ceiling Height 1001-1500 ft) | +1.832(Ceiling Height<1000 ft) |
| +0.201(Visibility<2 SM) | +1.639(Ceiling Height 1001-1500 ft) |
| -1.941(Visibility 2-4 SM) | +2.428(Visibility<2 SM) |
| -0.366(Visibility 4-6 SM) | +1.186(Visibility 2-4 SM) |
| +0.317(Visibility 6-8 SM) | +1.741(Visibility 4-6 SM) |
| +1.660(Fog) | +0.322(Visibility 6-8 SM) |
| -0.292(Crosswind 2-5 kt) | -0.532(Crosswind 2-5 kt) |
| +1.598(Crosswind 5-12 kt) | +1.566(Crosswind 5-12 kt) |
| +1.781(Crosswind>12 kt) | +0.986(Electrical Storm) |
| -0.536(Temperature<5°C) | +1.926(Icing Conditions) |
| -0.507(Temperature 5-15°C) | +1.499(Snow) |
| +0.502(Temperature>25°C) | -1.009(Temperature<5°C) |
| +1.805(Icing Conditions) | --0.631(Temperature 5-15°C) |
| +2.567(Snow) | -+0.265(Temperature>25°C) |
| -0.619(Commuter Aircraft) | +1.006(Non Hub Airport) |
| -0.009(Medium Aircraft) | -+0.924(Significant Terrain) |

Table 3. Values of Deceleration Model parameter p depending on terrain type [10]

| Ground Type | p |
|------------------------------|----------|
| Wet Grass/Dry Grass/Pavement | -0.0185 |
| Mud/Gravel | -2.8065 |
| Obstacles/Water | -8.5365 |

Table 4. Pearson Correlation coefficients associated to every combination of factors (second line reports the corresponding p-values)

| | Je t/ Tu rbo | Lo- cal/ For eign | Commer- cial/ Cargo/GA | MT OW | T | Fo g | Sn ow | El. Storm | Cross- wind | Cei ling |
|---|-----------------------|----------------------------|------------------------------|--------------------|-----------|-------------------|--------------------|-------------------|----------------|-------------|
| Lo- cal/Foreign | - | | | | | | | | | |
| <i>p</i> | 0,029 0 | | | | | | | | | |
| Commer- cial/ Car- go/GA | 0, 184 | 0,0 23 | | | | | | | | |
| <i>p</i> | 0 | 0,0 03 | | | | | | | | |
| Mtow | - | - | -0,769 | | | | | | | |
| <i>p</i> | 0,297 0 | 0,007 0,3 7 | 0 | | | | | | | |
| T | 0, 003 | 0,0 13 | 0,024 | - | | | | | | |
| <i>p</i> | 0, 698 | 0,0 98 | 0,003 | 0,015 0,0 63 | | | | | | |
| Fog | 0, 01 | 0,0 02 | -0,003 | - | - | | | | | |
| <i>p</i> | 0, 216 | 0,7 85 | 0,686 | 0,001 0,9 1 | 0,3 0 | | | | | |
| Snow | - | - | -0,009 | 0,0 05 | - | - | | | | |
| <i>p</i> | 0,003 0, 747 | 0,014 0,0 73 | 0,267 | 0,5 03 | 0,17 0 | 0,03 0 | | | | |
| El. Storm | - | - | 0,009 | - | 0, 121 | - | - | | | |
| <i>p</i> | 0,003 0, 702 | 0,008 0,3 39 | 0,277 | 0,003 0,6 6 | 0,6 0 | 0,048 0 018 | 0,019 0, 018 | | | |
| Cross- wind | 0, 005 | 0,0 01 | 0,005 | 0,0 01 | 0, 124 | - | - | 0,19 3 | | |
| <i>p</i> | 0, 513 | 0,9 48 | 0,534 | 0,9 0 | 0 0 | 0,124 0 | 0,017 0, 034 | 0 0 | | |
| Ceiling | 0, 006 | - | 0,009 | - | 0, 061 | 0, 07 | - | 0,01 7 | 0,044 | |
| <i>p</i> | 0, 434 | 0,005 0,5 44 | 0,233 | 0,006 0,4 11 | 0,61 0 | 0,07 0 | 0,1 0 | 0,03 0,03 1 | 0 | |
| Visibility | 0, 005 | 0,0 07 | 0,04 | - | 0, 022 | - | - | - | 0,077 | 0,2 36 |
| <i>p</i> | 0, 531 | 0,3 53 | 0 | 0,0 05 | 0,0 0 | 0,519 0 | 0,174 0 | 0,055 0 | 0 | 0 |

Highlights

- Two-step probabilistic procedure for the topological characterisation of overrun risk in airports
- Monte Carlo simulation applied to existing overrun probability and location models.
- Proposed topological severity index: iso-Kinetic Energy Areas (KEA).
- Expected kinetic energy almost constant for about 1,000 m beyond the runway end.

Accepted manuscript