



- (51) International Patent Classification:
A61H 1/02 (2006.01) A61F 4/00 (2006.01)
- (21) International Application Number:
PCT/IB2018/051652
- (22) International Filing Date:
13 March 2018 (13.03.2018)
- (25) Filing Language: Italian
- (26) Publication Language: English
- (30) Priority Data:
102017000027918 14 March 2017 (14.03.2017) IT
- (71) Applicant: POLITECNICO DI MILANO [IT/IT]; Piazza Leonardo da Vinci, 32, I-20133 Milano (IT).
- (72) Inventors: PEDROCCHI, Alessandra Laura Giulia; c/o Politecnico di Milano, Piazza Leonardo da Vinci, 32, I-20133 Milano (IT). FOGLIA, Giovanni Maria; c/o Politecnico di Milano, Piazza Leonardo da Vinci, 32, I-20133 Milano (IT).
- (74) Agent: DI BERNARDO, Antonio et al.; c/o Thinx S.r.l., Via Paleocapa, 7, I-20122 Milan (IT).
- (81) Designated States (unless otherwise indicated, for every kind of national protection available): AE, AG, AL, AM, AO, AT, AU, AZ, BA, BB, BG, BH, BN, BR, BW, BY, BZ, CA, CH, CL, CN, CO, CR, CU, CZ, DE, DJ, DK, DM, DO,

DZ, EC, EE, EG, ES, FI, GB, GD, GE, GH, GM, GT, HN, HR, HU, ID, IL, IN, IR, IS, JO, JP, KE, KG, KH, KN, KP, KR, KW, KZ, LA, LC, LK, LR, LS, LU, LY, MA, MD, ME, MG, MK, MN, MW, MX, MY, MZ, NA, NG, NI, NO, NZ, OM, PA, PE, PG, PH, PL, PT, QA, RO, RS, RU, RW, SA, SC, SD, SE, SG, SK, SL, SM, ST, SV, SY, TH, TJ, TM, TN, TR, TT, TZ, UA, UG, US, UZ, VC, VN, ZA, ZM, ZW.

(84) Designated States (unless otherwise indicated, for every kind of regional protection available): ARIPO (BW, GH, GM, KE, LR, LS, MW, MZ, NA, RW, SD, SL, ST, SZ, TZ, UG, ZM, ZW), Eurasian (AM, AZ, BY, KG, KZ, RU, TJ, TM), European (AL, AT, BE, BG, CH, CY, CZ, DE, DK, EE, ES, FI, FR, GB, GR, HR, HU, IE, IS, IT, LT, LU, LV, MC, MK, MT, NL, NO, PL, PT, RO, RS, SE, SI, SK, SM, TR), OAPI (BF, BJ, CF, CG, CI, CM, GA, GN, GQ, GW, KM, ML, MR, NE, SN, TD, TG).

Declarations under Rule 4.17:

— of inventorship (Rule 4.17(iv))

Published:

— with international search report (Art. 21(3))
— in black and white; the international application as filed contained color or greyscale and is available for download from PATENTSCOPE

(54) Title: DEVICE FOR CONTROLLED ASSISTANCE OF THE GRIP

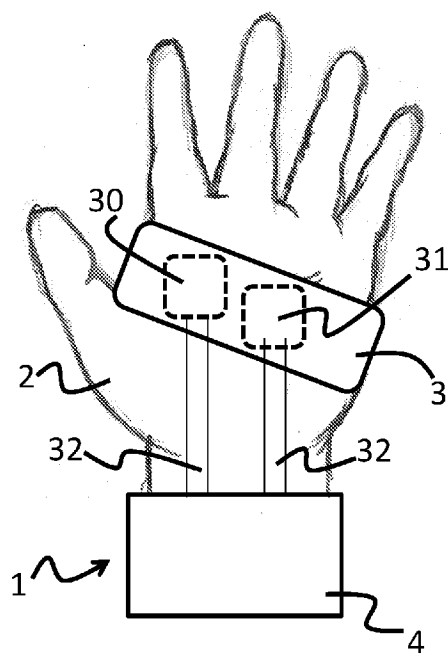

Fig. 1

(57) Abstract: The present invention relates to a device (1) for the controlled assistance of the grip, comprising a first element (3), which can be worn on one hand, and which comprises a pair of ferromagnetic plates (30, 31). The device then comprises a second element (4) which comprises a ferromagnetic core (40) whose opposite poles are each connected to one of the two ferromagnetic plates (30, 31). The device further (1) comprises a power supply unit (5) connected to an excitation coil (42) wound around the ferromagnetic core (40). A control unit (6) controls the voltage supplied by the power supply unit to the ends of the coil (42), so as to adjust the magnetic field generated to the ferromagnetic plates (30, 31).



DEVICE FOR CONTROLLED ASSISTANCE OF THE GRIP**DESCRIPTION****TECHNICAL FIELD**

The present invention relates to the field of magnetic gripping devices.

The invention finds its preferred application in subjects suffering from neuromotor disability of the hand, whereby the person needs assistance to grasp and lift objects. However, the invention is not limited to this application
5 and can also be applied in other fields, such as sports, where there is a need to assist in a variable way the manual grip capacity of a person.

In particular, the invention relates to a device according to the preamble of claim 1.

PRIOR ART

10 Nowadays there are several devices to improve the gripping ability of people who have lost the full or partial functionality thereof, such as multiple sclerosis patients, or those who have suffered a stroke.

Patterson Medical Holdings, Inc. manufactures telescopic rods at one end of which are pliers that can be operated by a simple mechanism, such as a trigger,
15 located at the other end. This allows people with little force in the arm, or even without a hand, to grasp and hold objects firmly. This solution, however, is cumbersome and not suitable for rehabilitation of the hand.

The North Coast Medical Inc. company, on the other hand, produces wristbands with the Norco™ brand, which can support the wrist and have a
20 magnetic band that crosses the palm of the hand. The magnet placed in the band allows to hold metal objects such as cutlery.

However, this solution also has some limitations, first of all the fact that it is not possible to regulate the strength of the magnet, therefore it is not possible to use this device to assist the patient in a rehabilitation process, encouraging him to
25 increase the force used to grasp an object. Moreover, this device is based on a constant magnetic action, which cannot be disabled by the user.

Some patent solutions have provided gloves with permanent magnets able to assist the grip. These solutions do not allow the activation/deactivation and

modulation of the assistance level provided by the magnet system and, being based on gloves, create a complete filter between the object and the hand, limiting the direct tactile perception of the subject.

Other known solutions provide for the use of exoskeletons, but even these have
5 the limit of being very complex, cumbersome and expensive.

The need is therefore felt for a device to assist in a controlled manner the gripping of a subject.

OBJECTS AND BRIEF DESCRIPTION OF THE INVENTION

The object of the present invention therefore is to provide a device for the
10 controlled assistance of the grip which solves the drawbacks of the prior art.

In particular, the object of the present invention is to implement a device that is easy to use and of simple construction.

These and other objects of the present invention are achieved by a device incorporating the features of the appended claims, which form an integral part
15 of the present disclosure.

In one embodiment, the device for the controlled assistance of the grip of a hand comprises a first element, wearable on the hand, on the palm where possible while on the back if the subject requested it, comprising a pair of ferromagnetic plates, preferably aligned through an appropriate structure. The
20 device then comprises a second element, electrically connected to the first element. This second element is preferably wearable on a person's wrist or arm or forearm, and comprises a ferromagnetic core whose opposite poles are each connected to one of the two ferromagnetic plates. This part could be fixed to the mechanical elements of an arm orthosis or exoskeleton, if the subject uses it.

25 The device further comprises a power supply unit connected to an excitation coil wound around the ferromagnetic core. A control unit controls the voltage supplied by the power supply unit to the ends of the coil, so as to adjust the magnetic field generated to the ferromagnetic plates, for example by activating it, deactivating it and also changing the level of assistance provided.

30 Ferromagnetic core, coil and power supply unit thus constitute an electromagnet whose magnetic field can be controlled by the control unit. This therefore allows to assist in a controlled manner the hand in the grip of any metallic ferromagnetic object (or any object to which a special ferromagnetic

contribution has been added), which is very important and useful in various applications, from rehabilitative recovery therapies of the hand functionality to the daily life of subjects suffering from functional disability of the grip, up to sports applications, such as training sessions in which it is necessary to control
5 the grip of the hand.

Advantageously, the ferromagnetic core comprises a strand of wires made of ferromagnetic material, which allows obtaining the necessary volume of ferromagnetic material without renouncing the flexibility necessary to wrap it around the wrist or arm.

10 In one embodiment, the ferromagnetic core and the coil form a self-winding spiral-shaped bracelet around the wrist. This allows a simple implementation of the device.

In an alternative embodiment, the ferromagnetic core and the excitation coil are arranged inside a band, preferably made of fabric, which comprises closure
15 means, in particular Velcro or buttons, at opposite ends. An easily wearable bracelet is thus obtained.

In another embodiment, the ferromagnetic core and the excitation coil can be inserted into a pocket or bag. Advantageously, then, the device also comprises an interface operatively connected to the control unit. The control unit is
20 configured to control the intensity of the magnetic field generated at the ferromagnetic plates in response to user commands received through the interface. This allows, therefore, an operator or the subject who wears the system to interact with the device to adjust the intensity of the magnetic field and, therefore, the assistance to the grip. In addition to determining the level of
25 assistance, the interface allows the person to activate or deactivate the assistance of the device, ensuring the attachment of the object and its release.

The invention is not limited only to the device, but also relates to a system for the controlled assistance of the grip of a hand comprising a hand grip assistance device of the type indicated above and better described below, and a user
30 terminal. The device for the assistance of the grip comprises a transceiver capable of receiving radio signals from the user terminal. The transceiver is operatively connected to the control unit for transmitting control signals received from the mobile terminal to the control unit, while the control unit is

configured to control the power supply unit in response to the control signals received from the user terminal.

The system can also comprise ferromagnetic elements, in particular bars, provided with suitable fixing means (e.g. adhesive, Velcro, etc.) for connecting
5 to commonly used objects, such that such objects can be effectively interfaced with the grip assistance device.

The invention is also directed to an exoskeleton incorporating the device for the controlled assistance of the grip of a hand.

Further features and objects of the present invention will become more
10 apparent from the following description.

BRIEF DESCRIPTION OF THE DRAWINGS

The invention will be described below with reference to some examples, provided for explanatory and non-limiting purposes, and illustrated in the accompanying drawings. These drawings illustrate different aspects and
15 embodiments of the present invention and, where appropriate, similar structures, components, materials and/or elements in different figures are indicated by similar reference numbers.

Figure 1 shows a device for the controlled assistance of the grip of a hand according to an embodiment of the present invention;

20 Figure 2 shows a detail of the device of figure 1;

Figure 3 shows a part of an electromagnet part of the device of figure 1;

Figure 4 shows a sectional view of figure 2;

Figure 5 shows a circuit diagram of the device of figure 1;

Figure 6 shows a hand rehabilitation system comprising the device of figure 1;

25 Figure 7 shows an alternative embodiment of the electromagnet used in the device of figure 1.

DETAILED DESCRIPTION OF THE INVENTION

While the invention is susceptible of various modifications and alternative constructions, some preferred embodiments are shown in the drawings and will
30 be described in detail below. It must be understood, however, that there is no intention to limit the invention to the specific embodiment illustrated, but, on the contrary, the invention intends to cover all modifications, alternative constructions, and equivalents that fall within the scope of the invention as

defined in the claims.

Use of "e.g.", "etc.", "or" means non-exclusive alternatives without limitation unless otherwise indicated. The use of "includes" means "include, but not limited to" unless otherwise indicated.

5 Figure 1 shows a device, indicated as a whole with reference number 1, for the assisted control of the grip of a hand 2.

The device 1 comprises a first element 3 which can be worn on the palm of the hand 2 and a second element 4 which can be worn on the wrist.

10 In one embodiment, the first element 3 is an annular band of fabric that surrounds the hand, so that it can be easily worn by inserting index, middle, ring and little fingers inside the band ring leaving outside the thumb.

Alternatively, the first element 3 can comprise a C-shaped rigid bar which can be worn on the hand by inserting the part of the hand between the thumb and the index inside the concavity of the folded bar.

15 In subjects that cannot open their hand, the C-shaped frame can be worn on the back rather than on the palm.

In general, the first element 3 is an element wearable on the palm or on the back of the hand which comprises a pair of ferromagnetic plates 30 and 31.

20 The shape of the element 3 can be any, such as a glove, although preferably the first element 3 is selected as small as possible in such a way as to leave most of the palm and the hand free, so as not to limit the direct tactile interaction of the person with the object, where the pathology does not affect the skin perception. For example, the first element 3 may be a band of fabric or a rigid bar whose width is substantially equal to the size of the ferromagnetic plates 30 and 31.

25 The ferromagnetic plates 30 and 31 correspond to the terminations (i.e. to the opposite magnetic poles) of a ferromagnetic core 40, visible in figures 2 and 3, inserted in the second element 4. The connection between the ferromagnetic plates 30 and 31 placed in the first element and the rest of the ferromagnetic core placed in the second element is made by two connections 32 which in
30 figure 1 pass over the palm of the hand, but which in a preferred embodiment slide on the back of the hand.

In the example in figure 1, the second element 4 is a bracelet, illustrated in detail in figure 2, comprising a band of fabric 400 provided with a pocket 401 for

housing the components of an electromagnet, which will be discussed further on. The band is closed around the arm by means of suitable closure means 402 which in the example in figure 2 consist of two Velcro strips. It is however possible to use other closure means, such as buttons, laces, hooks or other.

5 In the preferred embodiment illustrated in figures 3 and 4, the electromagnet comprises a ferromagnetic core 40 consisting of a strand of interlaced cables 41 made of ferromagnetic material, e.g. iron or alloys comprising iron, such as Fe-Si or Fe-Ni-Mo. This allows to obtain a core with the necessary flexibility to allow the bending thereof necessary for the bracelet 4 to be worn on a wrist.

10 Around the core 40 a coil 42 is wrapped, consisting of electrical conductors 43, e.g. of copper or aluminum, to which a variable voltage is applied in order to generate a magnetic field through the ferromagnetic core 40 and in particular to the plates 30 and 31 placed on the first element 3 and connected to the ferromagnetic core 40, of which they constitute the two magnetic poles.

15 In order to generate the necessary supply voltage of the coil 42, the device 1 is provided with a power supply unit 5, visible in the electric diagram in figure 5, capable of generating a variable voltage V_{out} . To this end, in the example in figure 5, the power supply unit 5 comprises a direct voltage generator 50 and a converter 51 able to vary the voltage supplied by the generator 50 and, consequently, the intensity of the magnetic field generated by the plates 30 and 20 31. By adjusting the intensity of the magnetic field, the device 1 will be able to attract metal elements with more or less force, and therefore to assist in an adjustable manner the hand in the grip of ferromagnetic objects or provided with ferromagnetic elements (e.g. ferromagnetic strips or bars placed with suitable fixing means, such as an adhesive or Velcro on common non-ferromagnetic objects).

A control unit 6 controls the converter 51 to adjust the voltage V_{out} in response to user commands that are received through an interface 7 or according to predetermined programs loaded into a memory area of the control unit 6.

30 In an embodiment, illustrated in figure 6, the interface 7 comprises a radio receiver, e.g. a Bluetooth or Wi-Fi receiver, capable of receiving commands transmitted from a user terminal 8, such as a smartphone or a tablet or a computer. This solution allows an operator to regulate the assistance that the

device 1 must give to the grip in a very simple way by acting on a device external to the device 1 and, therefore, not cumbersome. For example, in a rehabilitative therapy, it is possible to place on a common object, such as a cup 9, a ferromagnetic band 10 which can be attracted by the electromagnet when activated. The operator can act on the user terminal 8, for example through a software application, to control the device 1 in such a way that the magnetic field is initially maximum, so as to maximize the force of the magnetic field generated by the plates 30 and 31, to then reduce the intensity of the magnetic field over time and, therefore, the assistance in gripping the object 9. In other situations, where the device is used to assist patients with degenerative diseases, the operator can act on the user terminal 8 to control the strength of the magnetic field increasing it upon the degeneration of the disease.

In general, the interface 7 can be provided with a transceiver for communicating with user terminals or other external devices. For example, in a very basic solution (suitable for example for subjects with difficulty in the precise positioning of the finger on a touch screen), the external device that sends commands to the interface 7 can be a simple remote control, with a few buttons, such as only 3 buttons: an activation-deactivation one, two for voltage regulation. Alternatively, however, the interface 7 can be connected by cable to user terminals or other external devices. In general, therefore, the device 1 can be equipped with a data transfer system capable of receiving signals from user terminals or other external devices.

In light of the above it is clear how the device 1 allows to achieve the prefixed objects allowing controlled assistance of the grip.

It is also clear that the embodiments described above do not have to be intended in a limiting sense, whereas the scope of protection of the invention is instead defined by the appended claims. Many variations are therefore possible. In one embodiment, the device for the controlled assistance of the grip of a hand may be part of an exoskeleton or an orthosis. The exoskeleton or the orthosis will therefore comprise a mechanical structure (and possibly also an electrical structure) which, in a known manner, can be worn by a user to enhance the capacities thereof, for example to help him move an arm where the user has suffered injury to the arm. In this embodiment, however, the

exoskeleton (or orthosis) will comprise, in the end worn on the arm, a device as herein described and claimed.

As stated above, many variations of the device are possible with respect to the preferred examples described above. For example, other circuit solutions for
5 controlling the magnitude of the magnetic field generated by the electromagnet are possible, for example, the interface 7 could comprise a touch screen, through which the operator can provide commands to the device 1 and optionally control the operating parameters thereof. Furthermore, the power supply unit could at most consist of a voltage generator and a switch that can be operated to
10 connect and disconnect the voltage generator to the coil.

In a preferred embodiment, the power supply unit 5 is mounted on the second element 4, for example it has compact dimensions which allow it to be housed in a pocket of the bracelet 4. This is, for example, possible using a battery of the type used for smartphones as a generator 50 and using an integrated circuit
15 comprising the necessary control logic for implementing the converter 51, the control unit 6 and the interface 7.

Alternatively, the power supply unit can be separated from the second element and connected to the latter by suitable cables and connectors. In this embodiment, the voltage converter and/or the control unit can be indifferently
20 placed on the bracelet wound on the wrist or be external thereto.

In one embodiment, then, the first element 3, which is worn on the hand, is shaped in such a way that the ferromagnetic plates 30, 31 are mounted on the back of the hand. In this configuration, the advantage of the direct sensorial interaction offered by the grip and the possible partial assistance in case of a
25 weak but still partially functional subject is lost, but the possibility to grip the objects is nevertheless obtained. This alternative may be necessary if the pathology does not allow the person to open the hand, but the hand is in a closed postural attitude (in a fist or pinch) due to spasticity, joint limitations, tendon retractions or other factors related to the pathology. A similar
30 configuration may be necessary if the subject is unable to guarantee an effective opening of the hand and therefore risks that the fingers interfere with the gripping attitude. Advantageously, if the ferromagnetic plates 30, 31 are positioned on the side of the back of the hand, the connections 32 are passed

over the palm of the hand. Preferably, in fact, the connections 32 are positioned so as not to occupy the side of the hand on which the ferromagnetic plates 30, 31 are positioned.

Furthermore, in order to be able to wear the second element 4 on the wrist it is not strictly necessary for the electromagnet to be inserted into a pocket of a fabric bracelet. The electromagnet could, in fact, have a sufficient rigidity to allow it to be folded in a spiral, as shown in figure 7, to be able to wear it.

As far as the sizing of the device is concerned, it is clear that the number of turns and the section of the coil cables, as well as the number of cables that make up the strand of the ferromagnetic core can be chosen differently depending on the application of the device and of the magnetic field strength to be generated with the electromagnet.

Below is an example of a preferred sizing of the device 1.

Assuming that one has to lift a weight equal to 1kg, the force to be developed is about 10 N (1 kg = 9.8 N).

Considering a magnetic circuit with work induction equal to $B = 0.5$ T, the magnetic pressure is around $10\text{N}/\text{cm}^2$ ($p = B^2/(2*\mu_0) = 0.5^2/(2*4*\pi*10^{-7}) = 99470\text{N}/\text{m}^2 = 9.95\text{N}/\text{cm}^2$).

Therefore, two ferromagnetic plates 30, 31 would be sufficient, each having an area equal to 0.5 cm^2 . This would also be A_{nuc} section of the ferromagnetic core that generates the field, and which is connected to the plates 30 and 31.

Assuming an air gap of 1 mm between each magnetic plate and the object to be lifted, the total air gap of the circuit is 2 mm.

To produce an induction $B = 0.5\text{T}$ with an air gap $g = 2$ mm we need a magnetomotive force $M = g*B/\mu_0 = 0.002*0.5/(4*\pi*10^{-7}) = 796$ A. Assuming the typical value of current density ($J = 4\text{ A}/\text{mm}^2$), a coil of total section $A_{\text{bob}} = M/J = 796/4 = 199\text{ mm}^2 \approx 200\text{ mm}^2$ is required.

Considering a copper conductor of section $A_{\text{cond}} = 0.1\text{ mm}^2$, $N_{\text{sp}} = A_{\text{bob}}/A_{\text{cond}} = 200/0.1 = 2000$ turns are required.

The dimension l_{ng} of the strand is a little higher than the diameter D (it must be taken into account that the electrical conductors are insulated): we assume $l_{\text{ng}} = 1.4*D = 1.4*\text{rad}q[A_{\text{cond}}*4/\pi] = 0.4\text{mm}$.

The overall dimensions $l_{\text{ng}}N_{\text{sp}}$ of the N_{sp} coils can be estimated as $l_{\text{ng}}N_{\text{sp}} =$

$$l_{ng} \cdot N_{sp} = 0.4 \cdot 2000 = 800 \text{ mm.}$$

Assuming to make $N_{st} = 5$ layers of turns, the linear dimensions are $l_{ng} l_{in} = l_{ng} N_{sp} / N_{st} = 800 / 5 = 160 \text{ mm.}$

This is therefore the minimum length L_{nuc} of the ferromagnetic core. Preferably,
 5 the ferromagnetic core is selected with a length greater than the minimum, in particular it is preferable to increase it by 20 - 25%, thus obtaining a length equal to $L_{nuc} = 200 \text{ mm.}$ The so obtained ferromagnetic core is rolled into a bracelet around the wrist or forearm, causing a space of a few cm. In summary, a possible sizing of a bracelet for the assistance of the manual grip of an object
 10 up to a maximum weight of 1 kg involves the use of a ferromagnetic core of section $A_{nuc} = 0.5 \text{ cm}^2$, and length $L_{nuc} = 20 \text{ cm}$, which could be wrapped (like a bracelet) around the arm near the wrist, or around the forearm, requiring 2 - 3 turns, and then causing a footprint of a few cm. Around the core $N_{sp} = 2000$ turns of a conductor of section $A_{cond} = 0.1 \text{ mm}^2$, with 5 layers of turns are
 15 wound.

The "bracelet" thus obtained is then "extended" to reach the ferromagnetic plates 30, 31 placed on the palm of the hand. To ensure a certain flexibility of these extensions, they should be made with a strand of ferromagnetic threads.

With these characteristics, the current in the conductor would be $I_{cond} = J \cdot A_{cond} = 4 \cdot 0.1 = 0.4 \text{ A.}$
 20

The diameter D_{sp} of the average coil of the conductor would be slightly higher than the outer diameter of the ferromagnetic core $D_{nuc} = \text{radq}[A_{nuc} \cdot 4 / \pi] = 8 \text{ mm.}$ Let's assume $D_{sp} = 10 \text{ mm.}$

The length of the average coil is $L_{sp} = \pi \cdot D_{sp} = 31.4 \text{ mm.}$

25 Assuming to use a copper conductor and assuming to operate at a temperature of $30 \text{ }^\circ\text{C}$, the resistivity is $\rho = 0.0177 \cdot 10^{-6}$.

The coil resistance is $R_{bob} = \rho \cdot N_{sp} \cdot L_{sp} / A_{cond} = 11 \text{ } \Omega$.

The required voltage is $V_{bob} = R_{bob} \cdot I_{cond} = 11 \cdot 0.4 = 4.4 \text{ V.}$

The required power is $P_{el} = V_{bob} \cdot I_{cond} = 4.4 \cdot 0.4 = 1.76 \text{ W.}$

30 The masses of the ferromagnetic core and of the coil are obtained by evaluating the volume and multiplying by the density. In detail, the core volume is $A_{nuc} \cdot (L_{nuc} + 0.3)$; L_{nuc} is increased by 30 cm, to take into account the "extensions" that the ferromagnetic plates 30, 31 must reach. The coil volume is $A_{bob} \cdot L_{sp}$,

while the iron and copper densities are 7650 and 9800 kg/m³. The core and coil masses are therefore approximately 180g and 50g respectively.

CLAIMS

1. Device (1) for the controlled assistance of the grip, comprising
- a first element (3) wearable on a hand, and
 - 5 - a second element (4) electrically connected to the first element
- characterized in that
- the second element (4) comprises
 - o a ferromagnetic core (40) whose opposite poles are connected to a
 - 10 pair of ferromagnetic plates (30,31) inserted in the first element (3), and
 - o an excitation coil (42) comprising electrical conductors wrapped around said core,
- and in that the device (1) further comprises
- a power supply unit (5) connected to said excitation coil (42) for
 - 15 providing a supply voltage (V_{out}) at the terminals of the excitation coil (42),
 - a control unit (6) adapted to control the supply voltage (V_{out}) delivered by said power supply unit (5).
- 20 2. Device according to claim 1, wherein said ferromagnetic core (40) comprises a strand of wires of ferromagnetic material.
3. Device according to claim 1 or 2, wherein the ferromagnetic core (40) and the coil (42) form a spiral-shaped bracelet that can be wrapped around a part of an
- 25 arm, in particular the wrist.
4. Device according to claim 1 or 2, wherein the ferromagnetic core (40) and the coil (42) are arranged within a band (400) which comprises closure means, in particular Velcro or buttons, at the opposite ends (402).
- 30 5. Device according to any of the preceding claims, wherein said second element includes means for holding said power supply unit (5) and said control unit (6).

6. Device according to claim 5, wherein said second element is a bracelet which comprises a band, preferably made of fabric, that can be wrapped around a wrist and comprising at least one seat for housing the ferromagnetic core (40),
5 the excitation coil (42) and the power supply unit (5).
7. Device according to any of the preceding claims, further comprising an interface (7) operatively connected to the control unit (6), wherein the control unit (6) is configured to turn on/off and possibly control the intensity of the
10 magnetic field generated at the plates (30,31) in response to user commands received through said interface (7).
8. Device according to any of the preceding claims, wherein when the first element is worn on the hand, said pair of ferromagnetic plates (30,31) are
15 positioned in correspondence with the palm of the hand.
9. Device according to any of the preceding claims, wherein when the first element is worn on the hand, said pair of ferromagnetic plates (30,31) are positioned in correspondence of the back of the hand.
20
10. Exoskeleton comprising a device according to any of the preceding claims.
11. System for the controlled assistance of a hand grip, comprising a device (1) according to any one of the preceding claims and a user terminal (8), wherein
25 the device (1) comprises a data transfer system, e.g. a radio transceiver, capable of receiving signals from said user terminal (8), said data transfer system being operatively connected to said control unit (6) for transmitting to said control unit (6) control signals received from said user terminal (8), said control unit (6) being configured to control the power supply unit (5) in response to control
30 signals received from the user terminal (8).
12. System according to claim 11, further comprising at least a ferromagnetic strip (10) provided with suitable fastening means, for example adhesive or

Velcro, adapted for connection to an object (9).

1/4

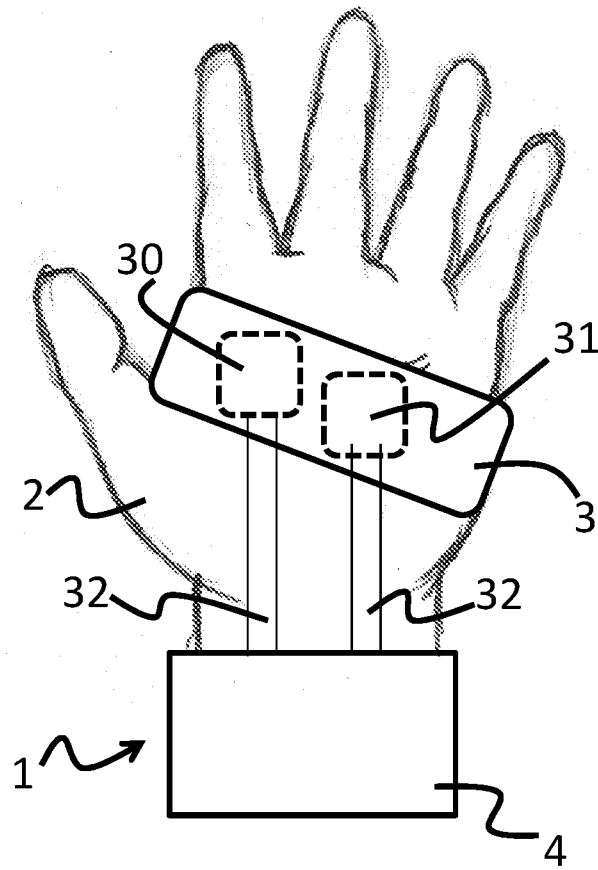

Fig. 1

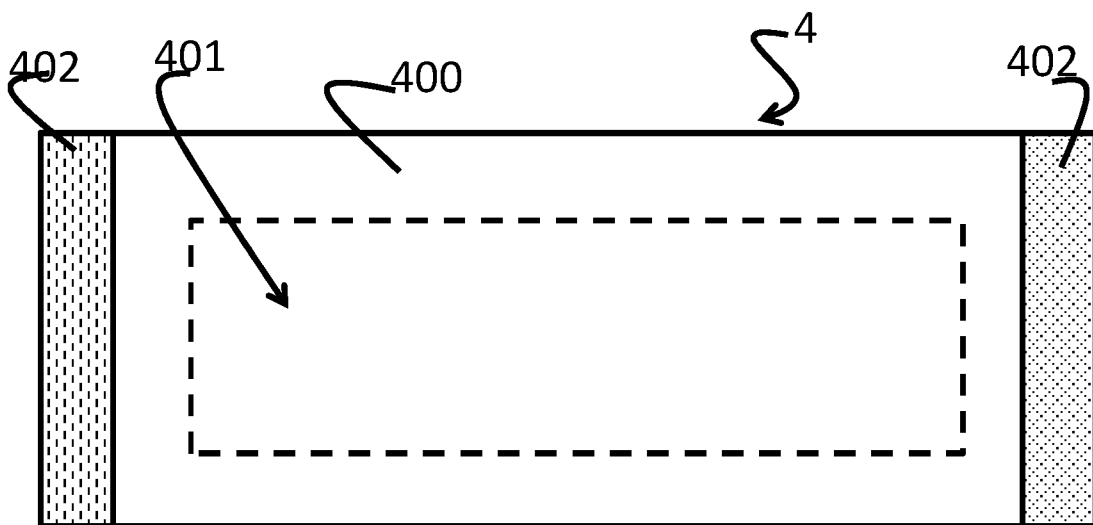

Fig. 2

2/4

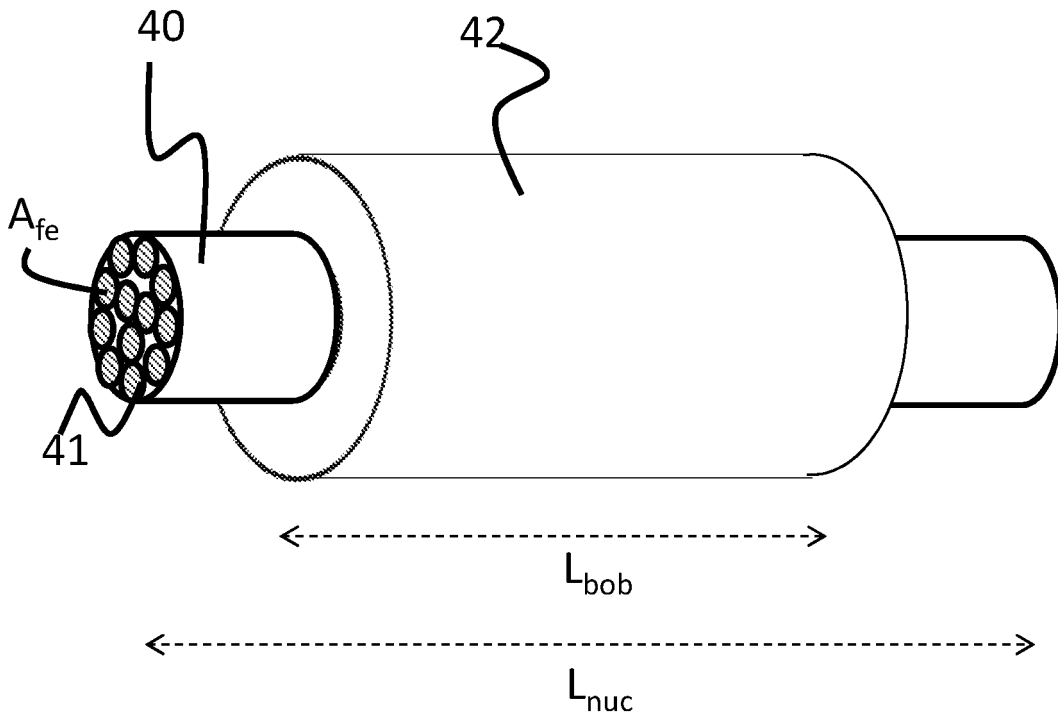

Fig. 3

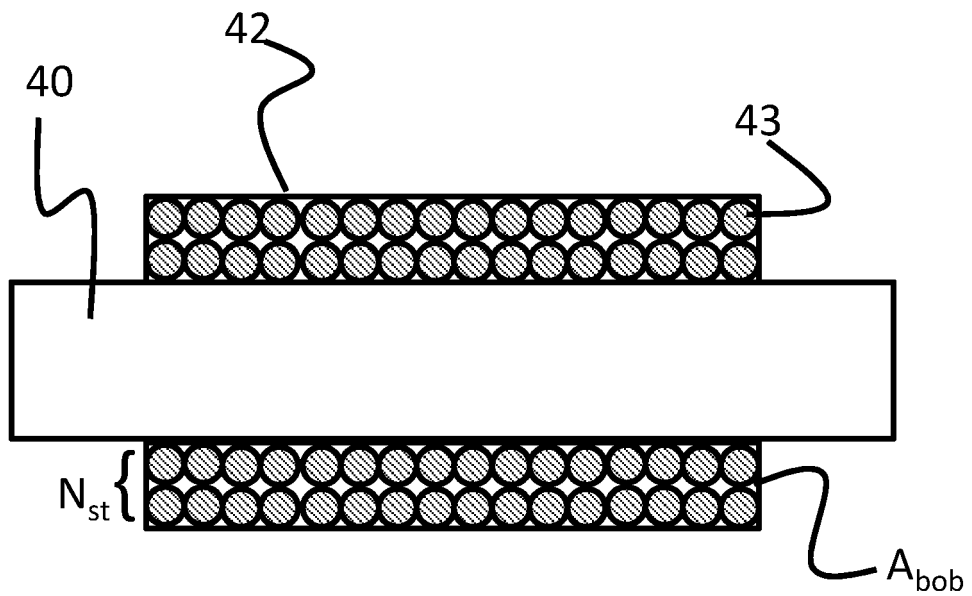

Fig. 4

3/4

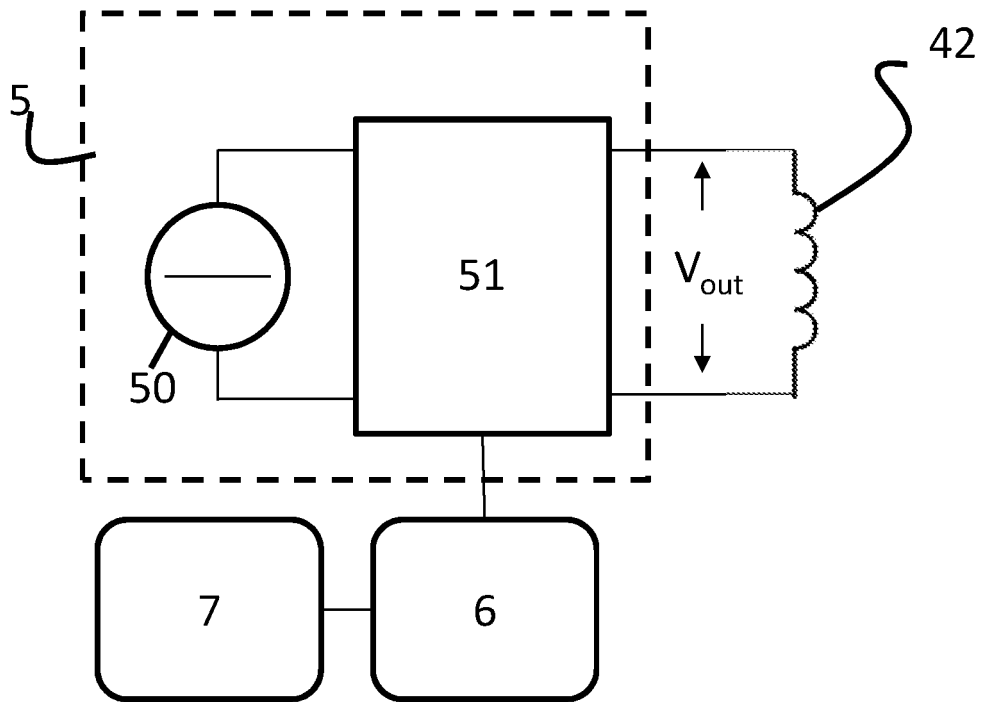

Fig.5

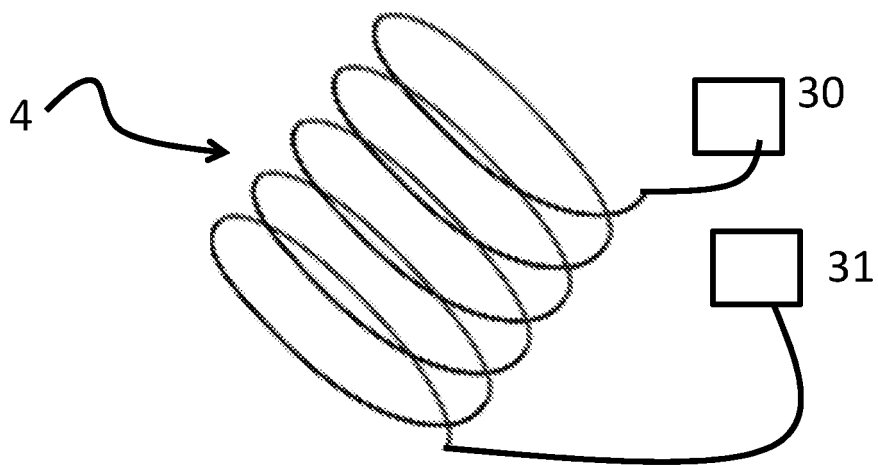

Fig.7

4/4

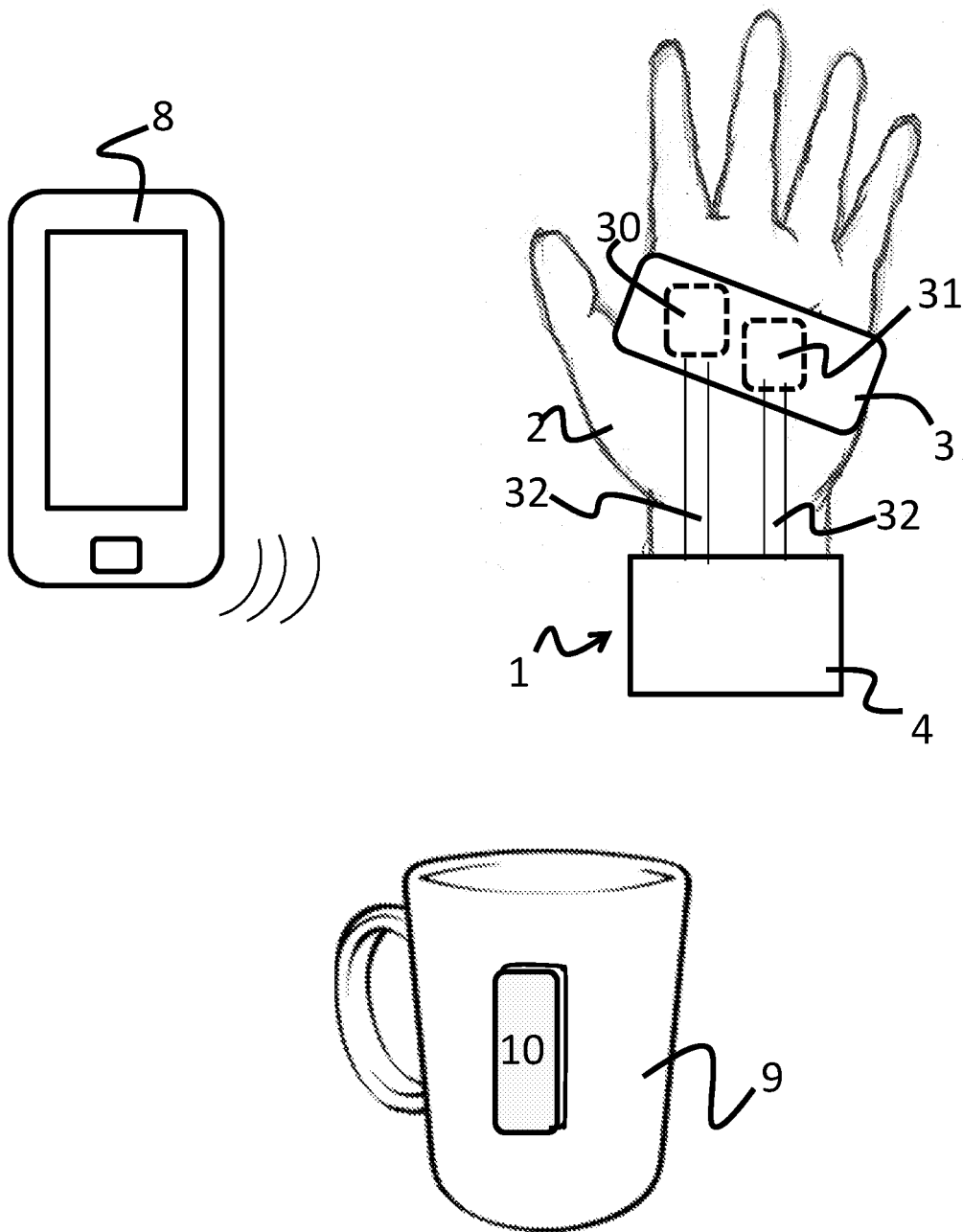

Fig.6

INTERNATIONAL SEARCH REPORT

International application No
PCT/IB2018/051652

A. CLASSIFICATION OF SUBJECT MATTER
INV. A61H1/02 A61F4/00
ADD.
According to International Patent Classification (IPC) or to both national classification and IPC

B. FIELDS SEARCHED
Minimum documentation searched (classification system followed by classification symbols)
A61H A61F

Documentation searched other than minimum documentation to the extent that such documents are included in the fields searched

Electronic data base consulted during the international search (name of data base and, where practicable, search terms used)
EPO-Internal, WPI Data

C. DOCUMENTS CONSIDERED TO BE RELEVANT

Category*	Citation of document, with indication, where appropriate, of the relevant passages	Relevant to claim No.
A	WO 2015/004643 A2 (FUNCTIONABLE S R L [IT]) 15 January 2015 (2015-01-15) Figs. 1 and 2 // claim 1 // band 5, adjustment magnets 18 -----	1-12
A	US 5 516 249 A (BRIMHALL OWEN D [US]) 14 May 1996 (1996-05-14) figures -----	1-12
A	WO 2016/088071 A1 (TELEBOT LABS S R L [IT]) 9 June 2016 (2016-06-09) figures -----	1-12

Further documents are listed in the continuation of Box C.

See patent family annex.

* Special categories of cited documents :

- "A" document defining the general state of the art which is not considered to be of particular relevance
- "E" earlier application or patent but published on or after the international filing date
- "L" document which may throw doubts on priority claim(s) or which is cited to establish the publication date of another citation or other special reason (as specified)
- "O" document referring to an oral disclosure, use, exhibition or other means
- "P" document published prior to the international filing date but later than the priority date claimed

- "T" later document published after the international filing date or priority date and not in conflict with the application but cited to understand the principle or theory underlying the invention
- "X" document of particular relevance; the claimed invention cannot be considered novel or cannot be considered to involve an inventive step when the document is taken alone
- "Y" document of particular relevance; the claimed invention cannot be considered to involve an inventive step when the document is combined with one or more other such documents, such combination being obvious to a person skilled in the art
- "&" document member of the same patent family

Date of the actual completion of the international search 29 May 2018	Date of mailing of the international search report 11/06/2018
Name and mailing address of the ISA/ European Patent Office, P.B. 5818 Patentlaan 2 NL - 2280 HV Rijswijk Tel. (+31-70) 340-2040, Fax: (+31-70) 340-3016	Authorized officer Foged, Søren

INTERNATIONAL SEARCH REPORT

Information on patent family members

International application No

PCT/IB2018/051652

Patent document cited in search report	Publication date	Patent family member(s)	Publication date
WO 2015004643 A2	15-01-2015	CA 2917929 A1	15-01-2015
		EP 3019125 A2	18-05-2016
		WO 2015004643 A2	15-01-2015

US 5516249 A	14-05-1996	NONE	

WO 2016088071 A1	09-06-2016	EP 3226824 A1	11-10-2017
		US 2017266075 A1	21-09-2017
		WO 2016088071 A1	09-06-2016
