

Seismic Structural Health Monitoring in some European countries

Abstract

This paper compiles and describes the national initiatives and projects on seismic Structural Health Monitoring (SHM) active in a number of European countries. Sensors networks and typical layouts, data processing techniques and policies adopted for the management of alerts are described for the different national programs. The different policies adopted for the access to data are also described. For the different countries applications to buildings, bridges or cultural heritage constructions are used to describe in detail the SHM systems installed in Italy, France, Greece and Portugal.

Introduction

Seismic Structural Health Monitoring (SHM) in seismic prone regions is a powerful tool in support of emergency management, and real-time performance assessment of structures. Data provided by the sensors installed on the structures can provide valuable information to the scientific and engineering community, allowing improvement of the understanding of the response of structures to earthquakes and the verification of algorithms for performance assessment. As a byproduct, information about the structural behavior provided by S²HM data support the updating the technical codes for constructions in seismic prone regions. In the past decades S²HM systems have been installed in several European countries in the framework of seismic risk prevention and mitigation policies. Monitoring systems operated by national services with civil protection functions are usually connected with a central server that processes data in real time. Indicators computed from data are used to assess the structural conditions and to trigger the deployment of further temporary monitoring system manage or the permanent storage of data in case of exceedance of some pre-defined thresholds.

S²HM in Italy: the Italian Seismic Observatory of Structures

In the framework of the national seismic risk prevention and mitigation policy, the Italian Department of Civil Protection (DPC) is engaged in numerous initiatives and projects related to the topic of Seismic Structural Health Monitoring. These includes promotion or direct participation to experimental campaigns aimed at the study of seismic strengthening techniques (Valente et al. 2006, Dolce et al. 2008) and/or development of methods, based on dynamic measurements, for the rapid evaluation of the vulnerability of existing strategic buildings (Mori et al. 2015).

However, the most important project of DPC in this field is definitely the development and the management of Osservatorio Sismico delle Strutture (OSS) (Dolce et al. 2015). The OSS is a network of permanent seismic monitoring systems installed in 152 public buildings, 7 bridges and 3 dams, whose primary civil protection scope is to provide quasi-real time remote information on the damage state of the monitored structures in case of an earthquake. With reference to buildings, 46 % of the monitoring systems are installed in schools, 20 % in hospitals, 19 % in town halls. The remaining 11 % are installed in churches, libraries, sports buildings and others. From the structural point of view, slightly less than two thirds of the sample consists of reinforced concrete buildings, a quarter of masonry buildings, while the remainder are a mixed construction or other structural types, such as steel or wood buildings.

The map of the distribution of the monitored structures is shown in Figure 1. They are distributed according to the level of seismic hazard, but, in any case, at least one monitored structure per region is present.

It took about twenty years for the OSS to reach its current inventory. The first systems were installed in 1999, while the last one was activated in July 2018. During this time very important sets of data have been collected, for example during the earthquakes of L'Aquila in 2009 (Spina et al. 2010), of Northern Tuscany in 2011 (Ceravolo et al. 2017) and, significantly, during the seismic sequence that affected Central Italy from 24 August 2016 to 18 January 2017.

Each of the civil structures belonging to OSS is equipped with a number of Force-Balance Accelerometers (FBA) for measuring and recording the seismic dynamic response of that structure to both weak and strong earthquakes. The working range of accelerometers is set according to local seismic hazard. Typically either ± 0.5 g (g is the gravity acceleration) or ± 1.0 g range is chosen for accelerometers on the ground and, correspondingly, either ± 1.0 g or ± 2.0 g range for accelerometers on the structure, to account for structural dynamic amplification. All systems acquire continuous data and store it in a temporary memory. When at least 70% of the signals exceeds a predetermined amplitude threshold, generally 0.001 g, the data are copied to a permanent memory and immediately sent to the DPC server through a dedicated internet connection. The typical sample rates for digitizing is 200 and 250 Hz. Regarding the number and position of the sensors installed, for buildings it is possible to identify some general criteria underlying the choices made in the system design, so that well defined types of systems can be identified. For bridges and dams the design of the accelerometers' layout is performed ad hoc for each specific case. In Figure 2 (left side) a general view of the "Santa Chiara" arch masonry bridge (Noto - Sicily) is shown and the sensor layout is presented on the right side of the same figure. The sensor layout (represented as black arrows) has been designed for monitoring both the lateral vibration of the piers and the vertical and lateral vibrations of the arches.

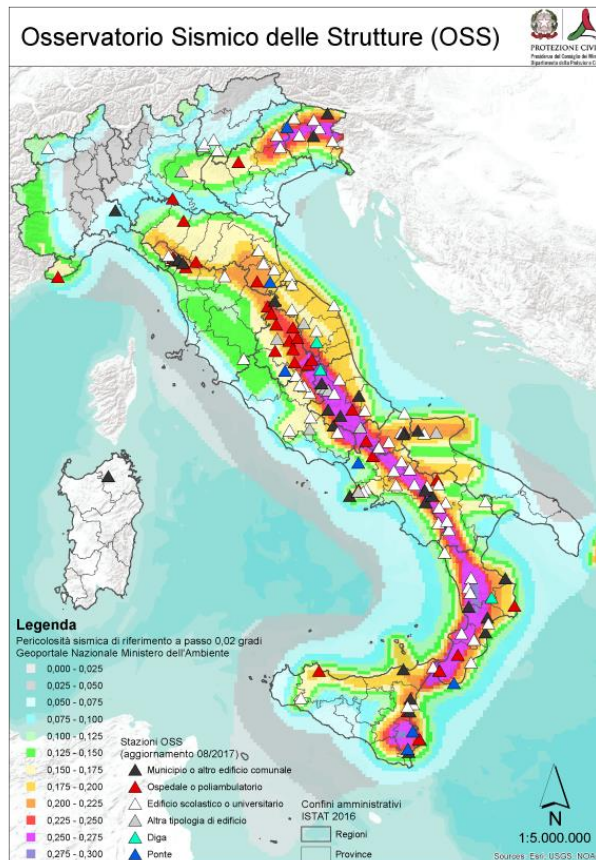

Figure 1– Geographical distribution of the structures of OSS in the Italian territory

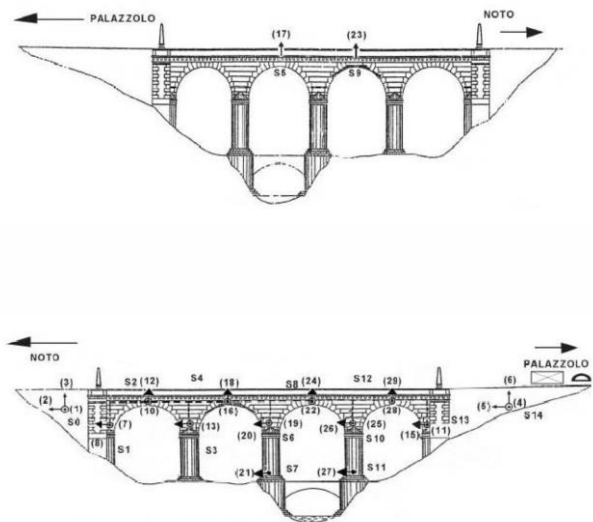
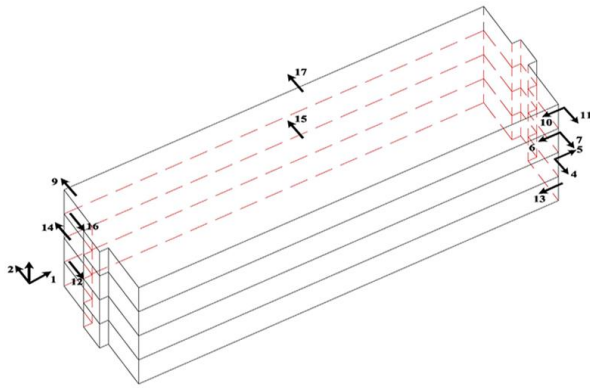

Figure 2- Santa Chiara bridge: general view (left) - sensor layout (right)

In the case of buildings, two different types of monitoring systems can be fundamentally distinguished: the "complete" and the "simplified" system. The complete systems, deployed in 129 buildings, are equipped with a three-axis accelerometer installed at the ground level plus a number of uniaxial accelerometers per floor sufficient to completely describe its seismic behavior, according to some rational reasonable kinematic assumptions. In the case of regular reinforced concrete buildings, as the one shown in Figure 3 on the left side, the rigid floor assumption allows to measure only three components of acceleration per floor (black arrows in the figure). For complex buildings, (e.g. the one in Figure 3 on the right), more components for floor are needed in order to properly represent the dynamic behavior.

Industrial Technical Institute
of Rimini (RN)



Elementary school
of Cesena (FC)

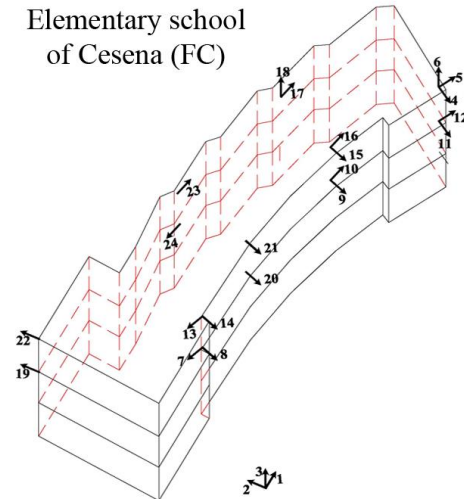

Figure 3 – Sensor system configuration and general view of a regular RC building (Industrial Technical Institute of Rimini, on the left side) and of an irregular one (Elementary school of Cesena, on the right side).

The analog signals of all the sensors are transmitted via cable to a central data logger with a 24-bit converter installed in the building, which provides for their conversion into digital. If certain acceleration thresholds are exceeded, data are stored in a fixed memory and transmitted via internet to the server in the headquarters of the DPC.

The installation of complete monitoring systems is always joined to surveys aimed to collect data on the geometry and mechanical characteristics of the structure. These data, together with the identified modal parameters are used to build and calibrate a Finite Element Model (FEM) of the structure.

In the 22 buildings equipped with simplified systems, only the top floor is instrumented synchronized with the ground excitation. Moreover, the number and position of the sensors is usually decided under the assumption of rigid floors. Each sensor is included in an Independent Device (ID) equipped with a 24-bit independent Analogical to Digital converter, a SSD disk for data storage and a GPS receiver to get the UTC time. Using the UTC time the signals recorded by different ID are synchronized and sent to a master ID using a WiFi network that, using a 4G router, sends data to the Central Server of DPC.

A recent development of OSS in building monitoring is represented by the system installed on the town hall of Recanati on July 2018. This is a sort of hybrid system between a complete and a simplified one. The town hall of Recanati is a clay brick masonry building built in 1898 in order to commemorate the hundredth anniversary of the great Italian poet Giacomo Leopardi's birth. As seen in Figure 4 it is a complex building, both from a geometrical and structural point of view, considering both the C-shape floor and the presence of different types of vaults. Moreover the town hall is not completely isolated because of the connection with the adjacent San Domenico Church

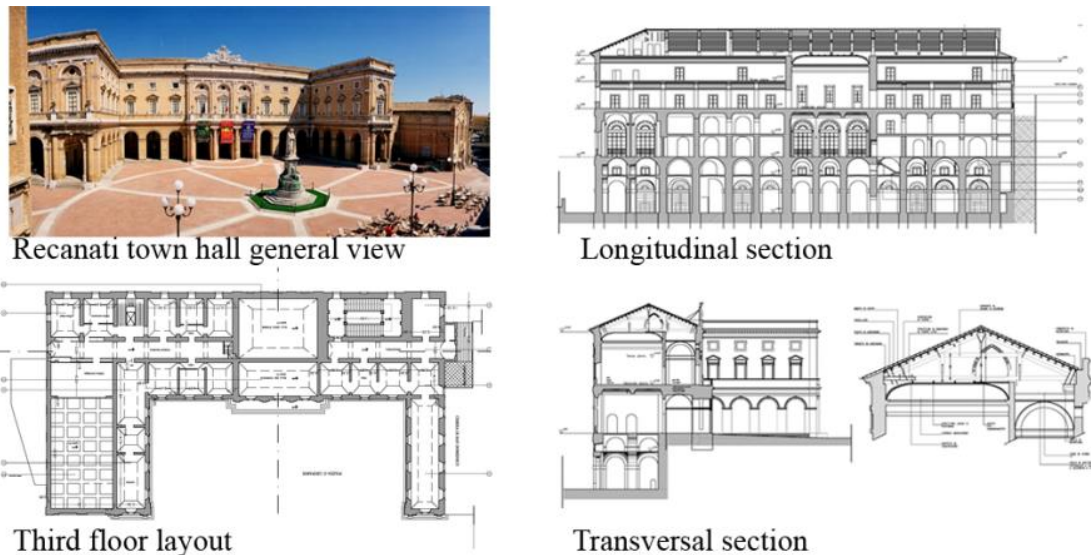

Figure 4 Recanati town hall: A general view, the third floor layout, longitudinal and transversal sections

The hallmark in this building is that, as for simplified system, only the top floor is instrumented, but, as for complete system, this floor is monitored in detail, in order to describe its deformability with accuracy. A three-axis ground sensor for measuring the seismic input is deployed at the base of the building. This sensor configuration is shown in Figure 5.

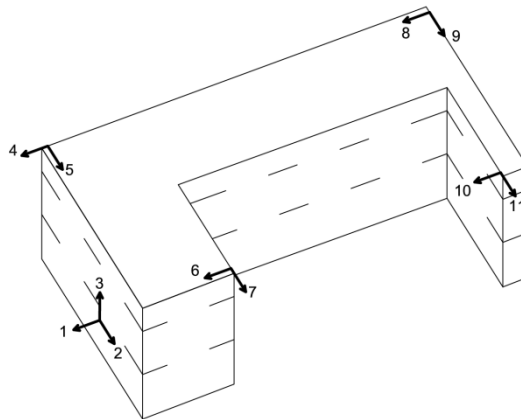

Figure 5 Recanati town hall: layout of the sensor deployment

Each two-axis accelerometer (slave sensors) is equipped with an integrated 24-bit Digital Analog converter. The three-axis accelerometer deployed on the ground (master sensor) receives the digital signals from the slave sensors through Ethernet cables and transmits all data to the central server through a 4G router.

Before deploying the permanent monitoring network a detailed equivalent linear model of the building (Mori et al. 2015) has been obtained by recording ambient vibrations through a temporary network of sensors installed at all the floors of the building. During seismic events, this model allows to retrieve approximate information about the dynamic response at the unmonitored floors using the signals recorded by the permanent network at the ground and at the top floor.

Data analysis and dissemination

Seismic data, recorded and sent to the DPC central server by the monitoring systems installed on structures involved in an earthquake, are immediately and automatically processed in order to perform a quick and rough damage assessment. The analysis is carried out by a Matlab script called RADOSS (Rapid Assessment Data of OSS). RADOSS is continuously connected to the web server of the Italian Institute of Geophysics and Volcanology (INGV) in order to receive, as soon as available, the magnitude and the epicentral geographic coordinates of the last earthquake. Immediately, after receiving this information, if the local or moment magnitude is equal to or greater than 3.0, RADOSS looks for the presence of recordings in the server which, for trigger time and geographical position, are compatible with the parameters of the earthquake reported.

Automatic data processing involves the calculation of the PGA in the three spatial directions, the maximum structural accelerations according to the two main horizontal axes of the structure and the estimation of a parameter that can be used for damage assessment.

For building as damage parameter is assumed the maximum inter-story drift (MIDR); for RC beam bridges is the structural members drift ratio related to failure; for a masonry arch bridges is the maximum vertical deflection. All these

dimensionless parameters related to displacements are obtained through double numerical integration and high pass filtering of the recorded accelerations. This hampers the detection of residual displacements related to damage or to plastic behavior.

At the end of the processing, the relative summary report, related to all the involved structures, together with the recorded data, are uploaded on the OSS website (www.mot1.it/OSSdownload). As an example, referring to the Amatrice earthquake of 24 August 2016 (MI=6.0), Figure 6 shows the map of the monitoring systems that recorded the event (left) together with the MIDR estimated by RADOSS for the eight building closest to the epicenter (right)

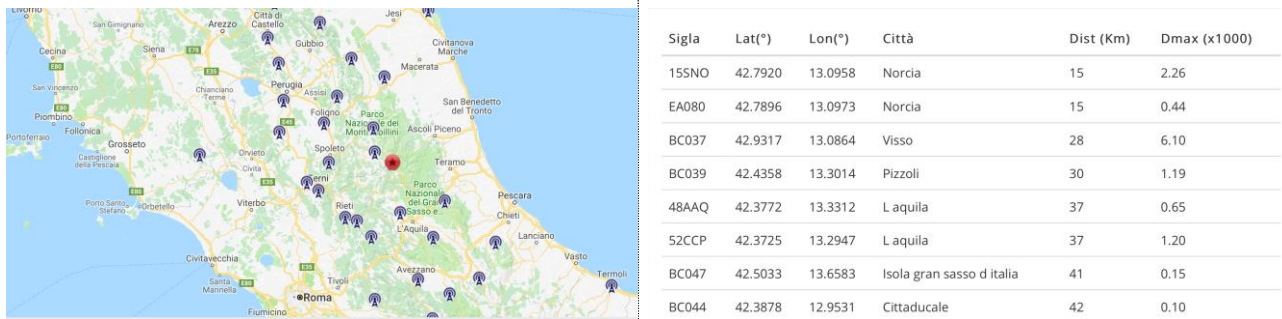

Figure 6 Amatrice earthquake of 24 August 2016 (MI=6.0): map of the monitoring systems that recorded the event (left) together with the MIDR estimated by RADOSS for the eight structures closest to the epicenter (right).

In addition to the automatic data processing described above, a more accurate damage assessment can be carried out, if it is considered appropriate, through the use of the MuDi (Multilevel Damage Identification) software platform (Acunzo et al. 2014). This platform has been designed for the OSS in the framework of a multi-year Research Project between DPC and ReLUIIS, a network of university laboratories of seismic engineering. The word “Multilevel” refers to the classification of damage proposed by Rytter (Rytter 1993): detection, localization, quantification and post-damage structural safety estimation. MuDi performs damage identification up to quantification. A set of modal parameters is identified on the structure in a reference condition and used as baseline. After a seismic event the modal parameters are identified from ambient vibrations using classical operational modal analysis techniques and used by the MuDi platform to apply in sequence several methods of Damage detection and localization. Quantification of damage is carried out using the new set of modal parameters to update a finite element model of the structure. It is important to underline that in this final step, the information about the location of damage is exploited by limiting the updating of the model to the mechanical characteristics of the damaged location.

Data recorded by the OSS are available on request and can be used for scientific purposes. In the following are reported some examples. The first one concerns data recorded on the Zingone Bridge (Figure 7), a fixed arch reinforced concrete bridge located in Mercato Saraceno (Forli, Italy) featuring a reinforced concrete of 54.9m length with a rise of 15.6m.



Figure 7. The Zingone bridge

Thirty-two seismic sensors were installed by the OSS to record the seismic behavior of the bridge: 26 sensors were placed on the structure and 6 sensors were located at two reference free field sites near the bridge (Figure 8). Responses are recorded in the vertical, longitudinal, and transversal direction of the bridge.

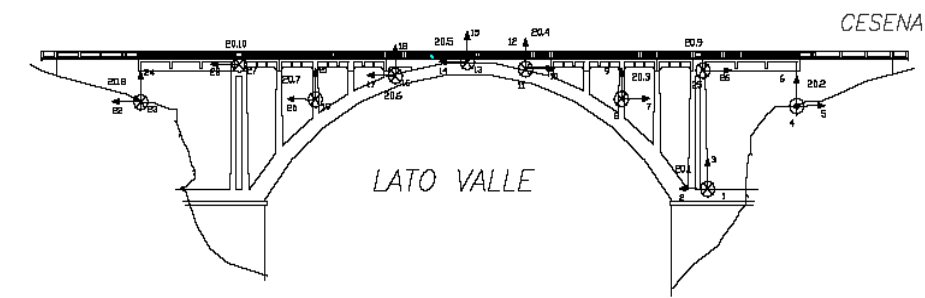

Figure 8. Zingone bridge: sensors location (courtesy of Servizio Sismico Italiano)

In reference (Limongelli 2004) earthquake data recorded during the San Leo-Novafeltria earthquake (August 1, 2000) on the Zingone bridge were used to check a technique to reconstruct seismic responses at locations not equipped with sensors. The technique is used, jointly with a criteria based on modal filtering (Limongelli 2003), to optimally locate a limited number of recording sensors for damage detection purposes. In

Figure 9 is reported the comparison between the recorded accelerations and the accelerations calculated using responses of a limited number of sensors at the optimal locations.

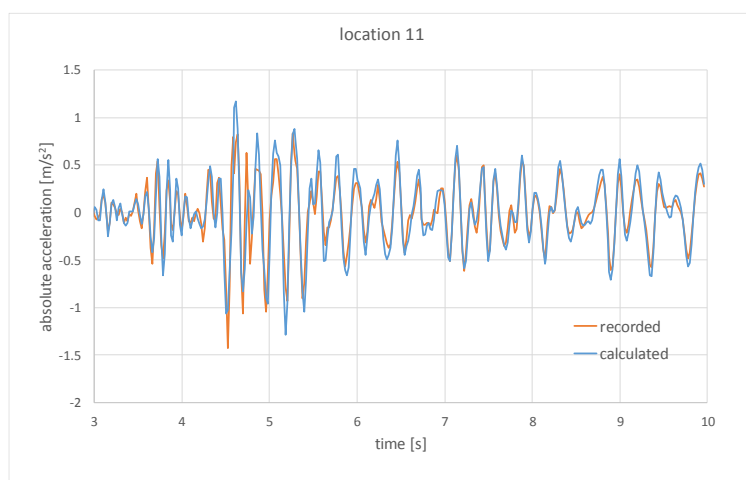

Figure 9. Zingone bridge: comparison of recorded and calculated accelerations

The second example is the Norcia School that, since 2002 is monitored by the OSS with the network of accelerometers shown in Figure 10. In 2010, was strengthened with dissipative braces in the longitudinal and transversal directions and in August 2016 was struck by the Central Italy earthquake. Between 2002 and 2017 several earthquakes have been recorded by the OSS sensors. In Figure 10b and Figure 11a and b are reported some of the damages to non structural elements after the 2016 earthquakes.

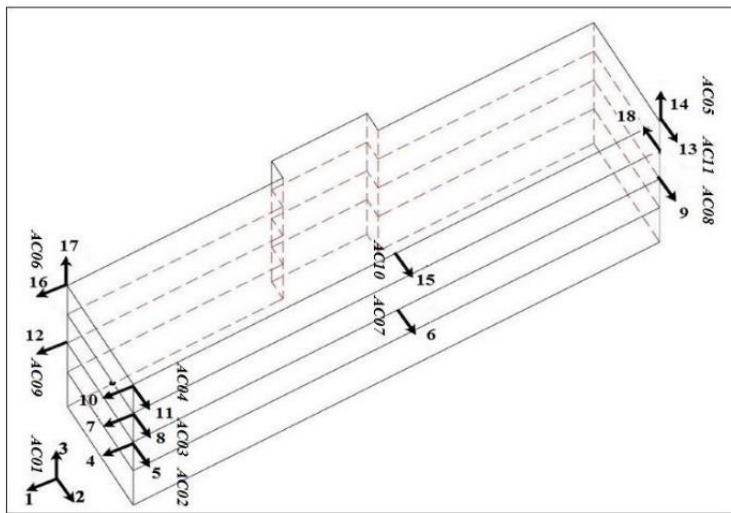

Figure 10. a) Norcia school. Sensor's layout; b) damages after August 2016 earthquake



a) August 24, 2016



b) November 3, 2016

Figure 11. Damages to non structural elements during the earthquakes in 2016

. The analyses of the evolution of the first modal frequencies (Figure 12) allow to clearly detect both the effect of the seismic upgrading through the dissipative braces (increase of modal frequencies between 2008 and 2013) and the evolution of damage induced by the sequence of seismic events starting from August 2016 to January 2017. The higher values identified during the last three seismic events (February to June 2017) are likely to depend on their lower intensity.

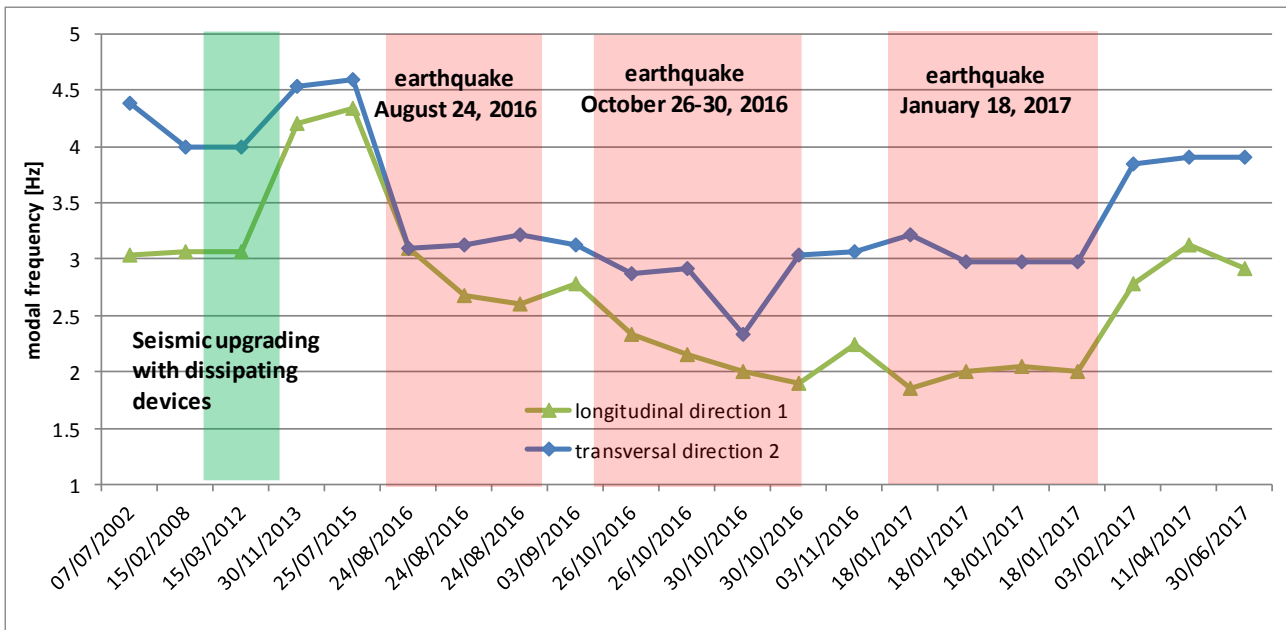

Figure 12. Evolution of modal frequencies in the longitudinal and transversal directions

A further example is relevant to the Cusumano bridge (Figure 13), located near Prioro Gargallo, in Sicily. Data recorded by the OSS enabled the calibration of a numerical model of the bridge. This model has been used to apply a pre-posterior Bayesian analyses for the computation of the Value of the Information retrieved by the network of sensors for the seismic emergency management of the bridge (Giordano et al.).



Figure 13. West side elevation of the Cusumano bridge

S2HM in France: the French National Building Array Program

The seismic hazard map of France clearly indicates relatively high (Antilles, Alps, Provence and Pyrenees) and moderate (Rhine Rift Valley, Ardennes and Armorica Massif) seismic prone areas.

The French National Building Array Programme consists in five reinforced concrete buildings, equipped permanently with accelerometric sensors, in mainland France and in the Lesser Antilles near the Caribbean subduction zone. Three are towers comprising more than 15 levels, one is a long building and the other is a seismic isolated building.

The RAP/RESIF permanent accelerometric network (<http://rap.resif.fr>) encompasses all French academic and public research institutes related to the definition and management of seismic risk (Péquegnat et al., 2008). It measures the seismic ground motion permanently in seismic areas as well as in certain exposed urban areas where ground motion prediction is essential.

The national permanent instrumentation program for buildings (NBAP: National Building Array Program) in France was launched ten years ago by RAP/RESIF to install permanent instruments in buildings and to record their response to seismic loading. This type of activity is not innovative in itself since at the end of the 1950s, California began its own

program initiated by seismologists (Californian Strong Motion Instrumentation Program), comprising around a hundred instrumented buildings. This project has recorded a number of major earthquakes (San Fernando, Whittier Narrows, Loma Prieta, etc.) and has influenced certain construction practices and regulations. Other highly seismic countries have followed California's example (Japan, Taiwan, ...) but unlike these networks, RAP/RESIF decided to make the data freely available based on the Californian model. RAP decision to publish these data is essential to generate added value, to check the quality of the data (currently this is the most efficient solution available) and to initiate collaborative projects with European and/or international academic partners.

Description of the buildings

Five buildings are instrumented in France (Figure 14). Although their constructions are different, they each represent a category of construction and design type typically found in France. As for the free-field stations, RAP choses to deploy sensitive systems with large dynamics to enable the recording of low to high amplitude signals ($\pm 1g$ full scale). They can be used to analyze the dynamic behaviour of the structures during local and/or regional earthquakes, to understand the relationships between their dynamics and design type, to analyze the relations between ground motion and structure deformation, to observe soil-structure interaction and to understand the non-linear phenomena that develop within the structure, in the foundation and/or at the soil-structure interface.

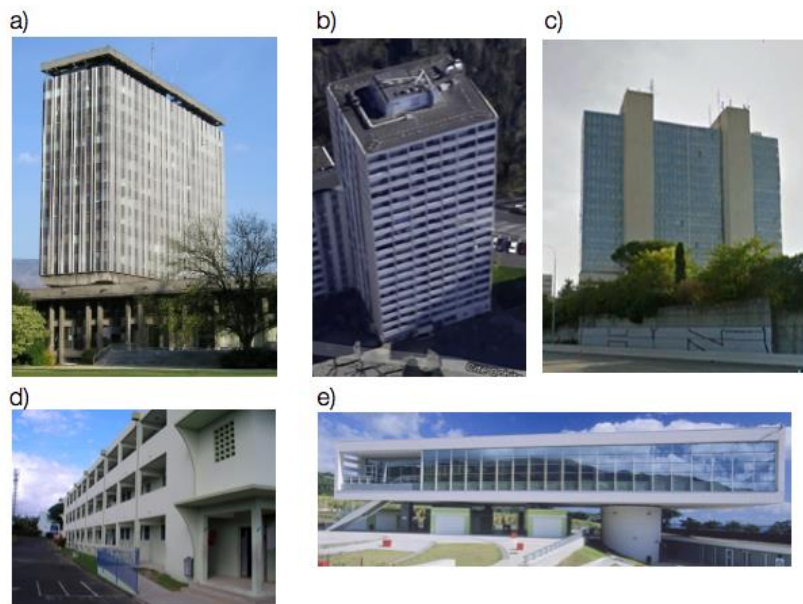

Figure 14. View of the buildings instrumented by RAP/RESIF. a) Grenoble City Hall (Alps region), b) Ophite tower (Lourdes, Pyrenean region), c) Nice Préfecture (South-East region), d) Basse-Pointe school (French lesser Antilles), e) Earth and science discovery centre (French Lesser Antilles)

Grenoble City Hall (Codes OGH1 to OGH6) has 18 accelerometric acquisition channels at the top and at the bottom of the structure (Figure 15a). It was the first building to be equipped with permanent instruments in France in 2004. It is located in a deep sedimentary valley of the Alps, near seismic sources. The building is 44m long, 13m wide and 52m high (Michel et al., 2010). Its main structural system is a concrete frame comprising pillars and beams bearing slabs, except for one pre-stressed concrete platform, which forms the third floor. The inter-storey height is 3.2m from the third floor up, 4.8m for the first floor and 8m for the second. It is a reinforced concrete construction, its lateral stiffness being ensured mainly by the lift shaft and staircase walls on either side of the main tower. The Grenoble City Hall building is resting on a superficial soil layer, 15-20m thick, of peat and soft clay, lying on a layer of sand and gravel. The building foundations are made from pillars anchored in the stiff layer of sand and gravel, at an approximate depth of 15m. Operation and maintenance of the network was entrusted to the Earth Science Institute (ISTerre) of Grenoble Alpes University/CNRS/IFSTTAR in November 2004. Initially, the data were in trigger mode, but following updating in 2010, the data are now recorded continuously and transmitted in real time to the national accelerometric data archiving centre (RAP-DC), which is part of the national seismology data center (RESIF-DC). The instrumentation program was partly funded by the city of Grenoble.

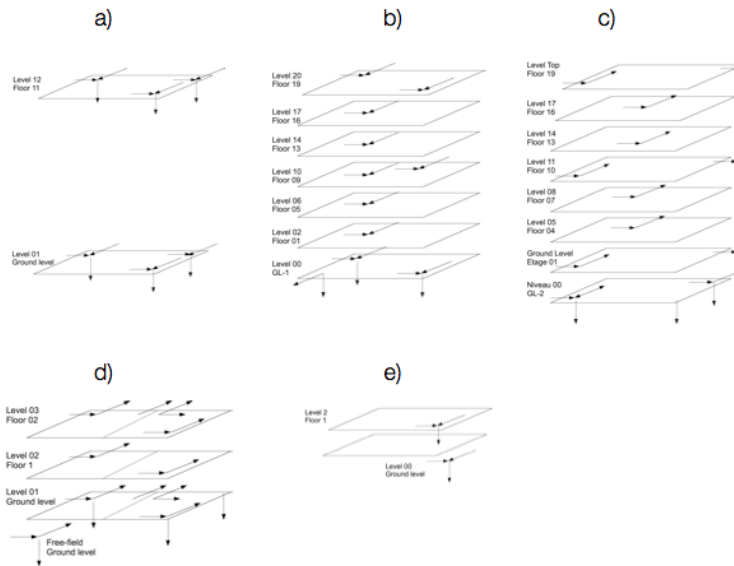

Figure 15. Position of the sensors in the buildings instrumented by RAP/RESIF a) Grenoble City Hall (Alps region), b) Ophite tower (Lourdes, Pyrenean region), c) Nice Préfecture (South-East region), d) Basse-Pointe school (French lesser Antilles), e) Earth and science discovery centre (French Lesser Antilles).

In February 2005, the **Earth and science discovery centre in Martinique** (Codes CGCP and CGLR) was equipped with two 3-component accelerometric stations (Guéguen, 2012). This building, located near an active seismic zone, comprises a seismic isolation system on rubber bearing: the two stations are located on the two faces of the bearing Figure 15e). It was built in 2004 in the form of a hollow, upper parallelepiped block, whose reinforced concrete walls make up the outer framework of the structure (50m x 18m). The slab of the upper block is made from reinforced concrete, 1.2m thick. It lies on rubber bearings on three reinforced concrete pillars ($H=7.90\text{m}$, $X=1.00\text{m}$, $Y=2.50\text{m}$) at one end, and on a hollow, circular column made from reinforced concrete containing the stairwell, at the other end. The external diameter of the column is 7.70m for an internal diameter of 6.30m. The pillars and column lie on stiff ground (EC8 type A) on superficial foundations, interconnected by a system of girders. The data are triggered and later sent to the national accelerometric data archiving centre (RAP-DC part of the RESIF-DC). The network is operated and maintained by the volcanological and seismological observatory of Martinique (OVSM/IPGP), a partner of the RAP network. The instrumentation was funded by Martinique regional council.

In October 2008, **Ophite tower** (code PYTO) in Lourdes (Mikael et al., 2013) was instrumented with 24 accelerometric channels spread out from the top to the bottom of the structure (Figure 15b). Located near an active seismic area, it lies on a rocky formation (Ophite) from which the building is named. It was the second building to be equipped permanently in mainland France. It was built from 1970s reinforced concrete (year of construction: 1972), with shear walls resisting system. It is a residential building and classed B by regulation EC8. Comprising 20 levels (basement + ground floor + 18 upper floors), it rises 50m above the ground, with ground dimensions of 24m (L) by 19m (T). It has a terrace roof. It is regular on the ground floor and upper levels. From the beginning, the data have been recorded continuously and transmitted in real time to the national accelerometric data archiving centre (RAP-DC part of the RESIF-DC). The earth sciences institute and Observatory Midi-Pyrénées (OMP) in Toulouse, is a partner of RAP operates and maintains the network. The operation was partly funded by the Pyrenees regional agency for development (DDT). Figure 16 shows an example of 24-hours continuous recording by a sensor at the bottom of PYTO during a nearby seismic events sequence.

The **Nice Préfecture tower** (code NCAD) was equipped in September 2010 with 24 accelerometric channels spread between the top and bottom (Figure 15c). This building, with 22 floors, is built over a sedimentary fill, near a seismic area (Fernandez-Lorenzo, 2016). It comprises two twin towers, separated by a 10cm thick joint. Only the western tower is instrumented in the vertical direction since the two towers are similar. Its resistance is mainly provided by reinforced concrete walls and partly by its external glass frontage. Located on a thick alluvial area, its foundations are deep, but no other information is available concerning their composition. Data recording has always been continuous with real time transmission to the national accelerometric data archiving centre (RAP-DC part of the RESIF-DC). The network is operated and maintained by Nice Sophia Antipolis University and CEREMA of Nice, partners of RAP.

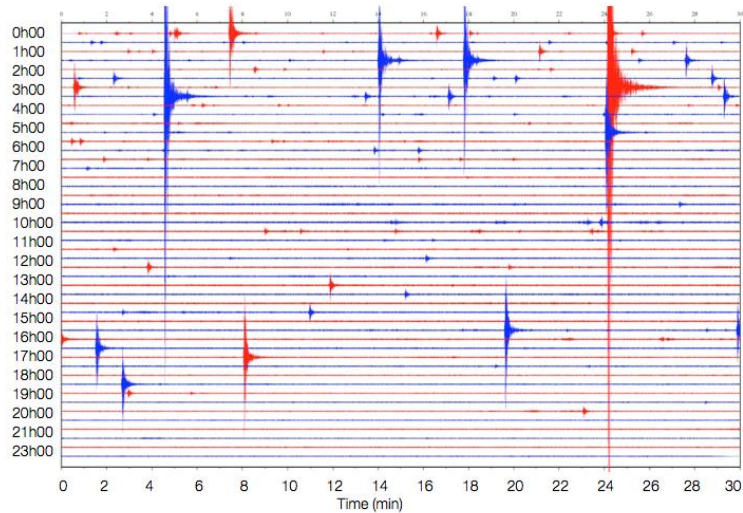

Figure 16. 24-hours recording at the bottom of Ophite tower during a seismic sequence in 2012.

Basse-Pointe school (Code CGBP) was equipped in January 2011 with 24 accelerometric channels spread along the main dimensions of the building (Figure 15d). It is located near a very active seismic zone, specifically the one that caused the Mw 7.4 earthquake in 2007. The building was constructed in the 1970s. It has a concrete frame structure, oriented along its transversal direction. Its longitudinal stiffness is mainly due to the stairwells located at its ends. The instrumented part comprises two blocks, separated by a 4-5cm thick construction joint. The building is used for teaching and therefore corresponds to EC8 regulation Type III. Its dimensions are regular at ground level, measuring 57m x 9m with a height of 10m (2 floors). All the floors are identical. We have no information on the foundations that are likely continuous superficial. Data has always been recorded continuously and transmitted in real time to the national accelerometric data archiving centre (RAP-DC part of RESIF-DC). The network is operated by the Institute of Earth Science (ISTerre) and jointly maintained by the volcanological and seismological observatory of Martinique (OVSM/IPGP). The building was instrumented in partnership with BRGM (RAP partner) with funding from Martinique regional council.

Data policy

When the network was created, RAP/RESIF decided to make all the recorded data, including data from buildings, available to the scientific community. These data include (1) metadata describing the stations and acquisition channels (i.e., sensor position, orientation, instrumental response, etc.), (2) wave shapes in miniSeed format, which is standard for sharing seismological data, and (3) information on station operation and data continuity. Triggered data corresponding to the largest earthquake events are also available. RAP national data center (RAP-DC) has been managing the data since 2000 and in 2012, it was integrated to the national RESIF-DC seismological data center hosted at Grenoble Alpes University. Data in matlab format, segmented by seismic events, can also be obtained from the authors.

All these data are accessed via various services, which are described on the RESIF data distribution portal (<http://seismology.resif.fr>) in the Data Access section (Figure 17). This portal also describes a number of solutions according to the type of data retrieved (wave form, metadata in txt or xml format, etc.) and data quality (real-time data or validated data), as well as downloading tools (e.g., via web-services developed by the Federation of Digital Seismograph Networks, FDSN, or by the Arclink system developed by EIDA for Europe). The EIDA system enables the interconnection of major European data centres via the Arclink system developed during the European projects NERIES and NERA, to which RAP/RESIF also contributes.

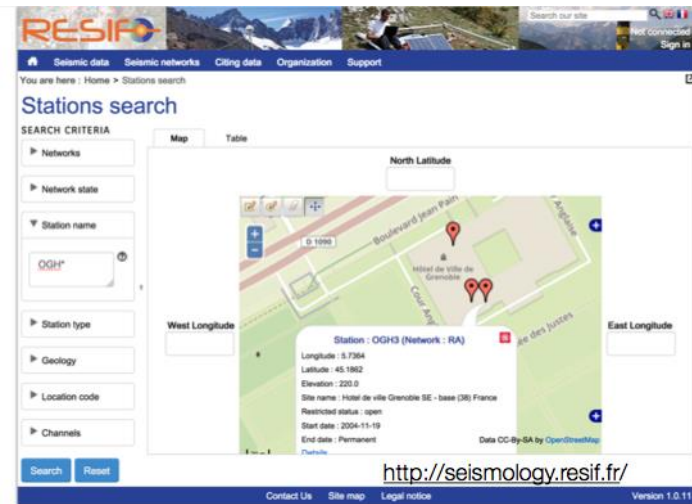

<http://ws.resif.fr/fdsnws/dataselect/1/query?network=RA&station=CGBP&quality=B&starttime=2017-06-01T22:44:00&endtime=2017-07-01T22:44:10&nodata=404>

Figure 17. Screenshot of the RESIF web portal to access data, and example of the web-service request that enables downloading a continuous window of data from the Basse Pointe school building (Code CGBP) between 01/06/2017 and 01/07/2017.

Each station transfers its data in real time directly to the RAP-DC via a SEEDLINK protocol on a ring buffer. The data are then pushed to the RESIF-DC after verification and a first level quality control. Some data quality (such as noise level) is processed automatically and can be viewed on-line on the RESIF portal. Figure 18 shows an example of data continuity from the PYTO station after this quality check.

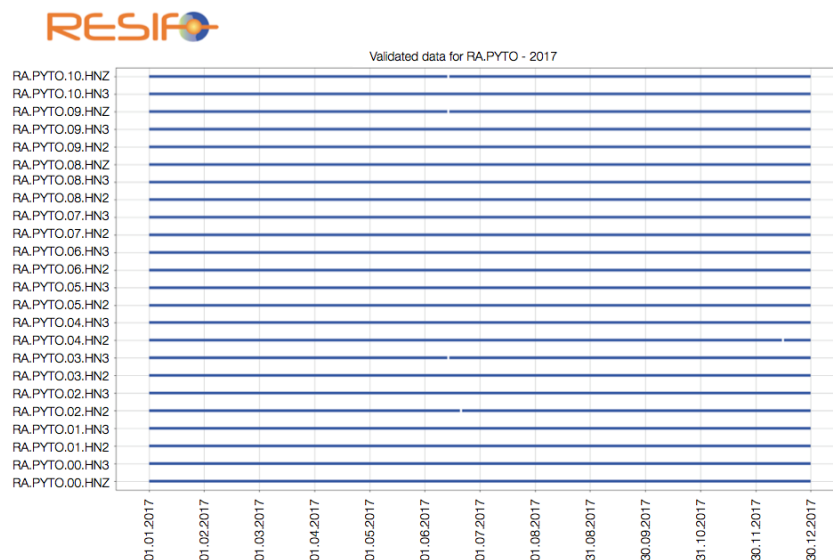

Figure 18. Example of data continuity from the 24 acquisition channels of the PYTO building for 2017.

Results at a glance

Added to the information provided in case of a significant earthquake, many scientific publications have been published using these data. These applications include:

- analysis of the seismic response of structures to moderate-to-strong earthquakes (in the Antilles) enabling better understanding of the specific behavior of these structures and their operation with respect to French regulations (e.g., Michel et al., 2010a; Guéguen, 2012);

- time monitoring of frequency and damping under changing atmospheric conditions (temperature, humidity, etc.) and in the event of an earthquake to understand the physical processes involved (e.g., Mikael et al., 2012; Larose et al., 2015; Guéguen et al., 2017);
- validation of structure vulnerability assessment methods using an experimental approach (e.g., Michel et al., 2010a; Guéguen, 2013);
- development of a modal analysis method applied operationally to detect changes in elastic properties (e.g., Nasser et al., 2016; Brossault et al., 2018);
- analysis of soil-structure interaction under seismic loading or ambient vibrations, and its evolution over time (e.g., Guéguen et al., 2017);
- detection and location of changes using seismic interferometry methods by deconvolution and modal approach (e.g., Michel and Guéguen, 2018).

Some of the important outcomes of these works relate to: (1) the physical significance of the variation of frequency and damping, information that can be used to characterize the health of the structure; (2) the non-linear behaviour of a building on rubber bearings suffering a magnitude 7.4 earthquake; (3) the development of combined experimental/empirical/numerical methods to characterize the physical vulnerability of structures.

S2HM in Greece – The ITSAK experience

The Institute of Engineering Seismology and Earthquake Engineering (www.itsak.gr) is a research center established in Thessaloniki in 1984, which was merged in 2011 with the Earthquake Planning and Protection Organization, becoming the research unit EPPO-ITSAK. Since its establishment, ITSAK has been particularly active in monitoring the seismic response of structures (S2HM), mainly during the aftershock sequence of major earthquake events. Due to space limitations, a concise description of the Institute's various efforts focused especially on the S2HM field is presented, together with some important conclusions for each instrumentation case. The interested reader can find more detailed information in the cited literature. In the majority of the cases presented herein, unless otherwise stated, high-resolution (>19-bit) special accelerometer arrays with several uniaxial sensors have been used, with common-trigger and common-time capabilities and a 200sps sampling frequency. ITSAK has also performed several other investigations based on the ambient vibration (operational) response of instrumented structures that are not presented herein. The authors welcome the interested readers to contact ITSAK for more information on its research efforts in the field of SHM/S2HM.

Instrumented Buildings

OTE building, Ano Liosia, Athens. On September 7, 1999 at 11:56 GMT a M5.9 earthquake, struck Athens, Greece. A few days after the main event, ITSAK instrumented (with a 19-bit special accelerometer array) the National Telecommunications (OTE) building (Figure 19a) in the municipality of Ano Liosia, near (≈ 10 km) the epicentral area, and recorded its response to several aftershocks for almost three weeks. The R/C building consists of two statically independent parts, separated by a 0.03 m expansion joint (Fig. 1a). A network of six sensors was used recording responses with a sampling rate of 100 sps, aiming, among others, at investigating the possible pounding between the two parts (**Errore. L'origine riferimento non è stata trovata.**b).

Two of the most intense recorded aftershock (of the order of 20-40 mg) were used to identify the dynamic properties of the building, using a custom software developed by the Department of Mechanical and Industrial Engineering of the University of Thessaly, Greece. The experimental results were used to properly calibrate the finite element model of the building (Figure 19c). The soil compliance was modelled through Winkler springs, with values of the spring constants corresponding to a dynamic behavior (i.e. almost an order of magnitude bigger than the static value). The values of the Winkler springs constants, recovered through a parametric investigation, allowed to obtain a good match between recorded and calculated accelerations, especially in the longitudinal direction. In Figure 19d is reported the comparison at the location of one of the sensors. For either parts of the building, the peak relative displacement computed from recorded accelerations exhibited values far lower than the dimension of the existing expansion joint. This is a strong indication that no pounding took place, at least for the examined events. A further indication towards this conclusion is the fact that the calibrated analytical model, in which no pounding simulation capabilities were provided, accurately described the recorded response.

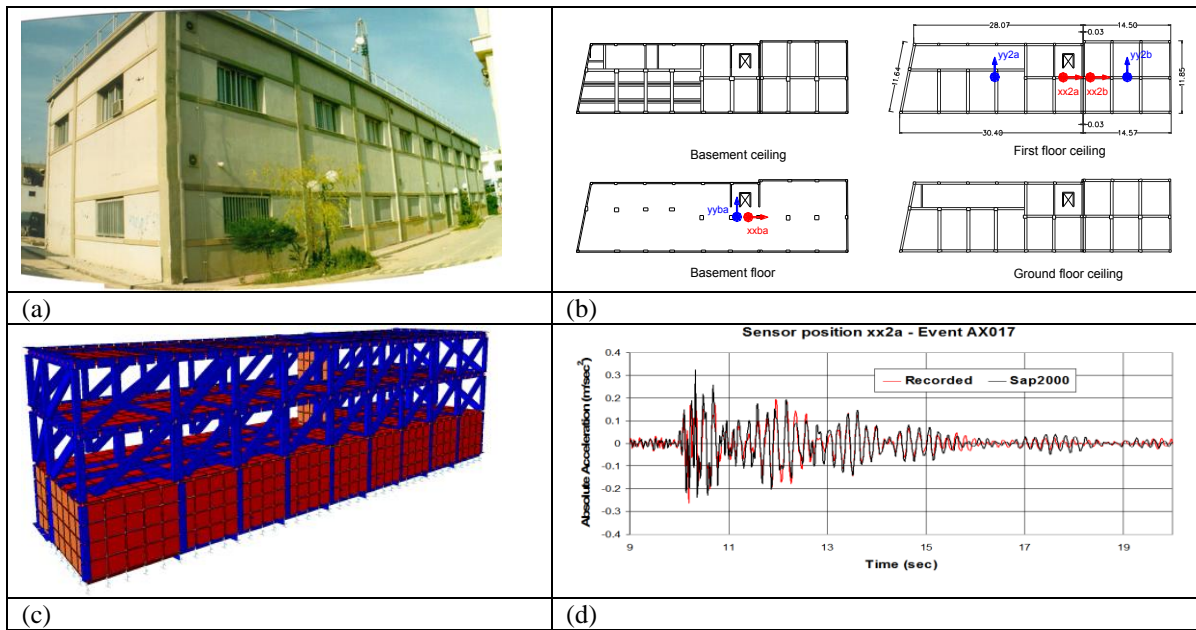

Figure 19. (a) OTE building at Ano Liosia (b) instrumentation layout (c) F.E. model (d) predicted vs recorded response (updated model, longitudinal direction).

OTE building, Thrakomakedones, Athens. For two weeks after the Ano Liosia earthquake, ITSAK monitored the seismic behavior of a respective (OTE) building (Figure 20a) in the municipality of Thrakomakedones, in the meizoseismal area. Damage due to the mainshock was limited to cracking at some of the interior infill brick walls, whereas the R/C load bearing system was unharmed. The same structural array was used, with nine sensors and 200sps sampling rate (Figure 20b). The selection of the particular configuration of the sensors aimed at the detection of the higher modes of the building, as well as at the detection of possible differentiations between the recordings of the two parallel sensors YBL and YBR at the basement (Karakostas et al., 2002).

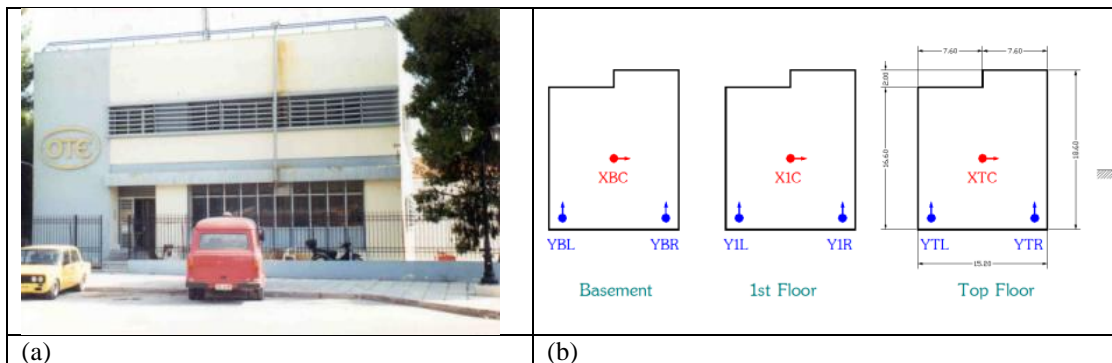

Figure 20. (a) OTE building at Thrakonakedones (b) instrumentation layout

During the monitoring period 21 aftershocks were recorded. Several of them were used to assess the dynamic characteristics of the building. It was found that the modal properties depend on the intensity of the earthquake. Specifically, the higher the intensity of the event, the higher the values identified for the period and the critical damping ratio. This shift is reversible, i.e. independent of the chronological order of the events. It must be noted that during the monitoring period, the building exhibited a virtually linear behavior during the aftershocks (i.e. no further damage to the infill walls was observed). This shift to longer periods for higher intensity excitations may be attributed to the formation of microcrackings as well as to the activation of various extra friction mechanisms in the structure (e.g. between the infill walls and the surrounding R/C structural frames). These are reversible phenomena that occur during excitations exceeding a certain intensity threshold, and which disappear at the end of the excitation.

As in the case of Ano Liosia, the identified dynamic parameters were used to update a Finite Element F.E. model of the building. An additional finding was the observable difference between the recordings at the two parallel sensors YBL and YBR deployed at the basement level. Given the small dimensions of the building, a possible cause may be a soil-structure interaction effect between the torsional response of the building superstructure and its foundation. This explanation was partly confirmed by the analytical investigations carried out on the calibrated FE model of the building. A detailed presentation of the experimental and analytical investigations of the two buildings can be found in Karakostas et al., 2002 and Karakostas et al., 2003.

Municipality Building, Korinthos. The Municipality building in the city of Korinthos (Figure 21a) was instrumented by ITSAK for six months in 2003. The load bearing system of the building consists of R/C shear frames (i.e. with no shear walls, apart from those at the basement perimeter). A 19-bit Kinematics K2[®] special array was used, together with 8 uniaxial FBA-11 accelerometers and a 200sps sampling rate. The instrumentation scheme, presented in Figure 21b, aimed at the determination of the main translational modes of the building. During the monitoring period, only one low intensity event was recorded (peak base accelerations 1.38 & 1.44 mg).

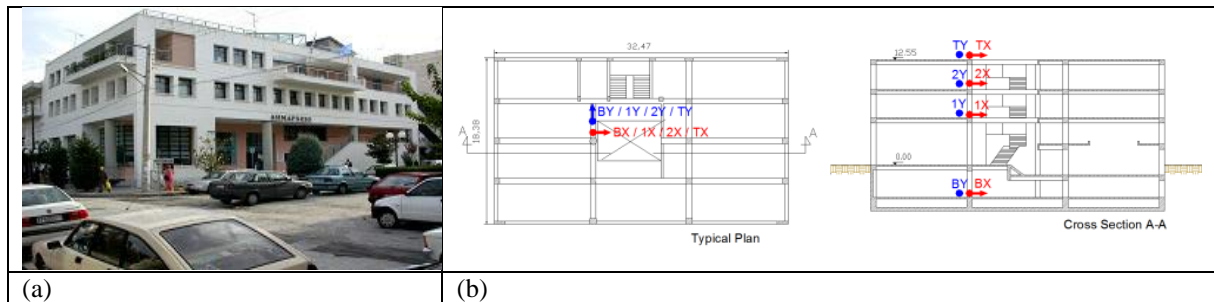

Figure 21. (a) Municipality building at Korinthos (b) instrumentation layout

The two fundamental periods were identified through the use of the relative PSD spectra of the recorded responses, yielding values of $T_x=0.19$ sec and $T_y=0.22$ sec (Makarios et al., 2006). For a quick cross-check between experimental and analytical results which can be performed even on site, the following relation can be used:

$$T = 0.09 H L^{-1/2} \{ H / (H + \rho L) \}^{1/2} \quad (1)$$

where H is the height of the building, L the length of the building along the assumed (x or y) direction and ρ the ratio of the area of the shear walls along the same direction to the total area of shear walls and columns (equal to 0 in case of shear frame systems, as in the present case). For the Korinthos Municipality building, eq (1) yields values of the periods equal to $T_x=0.20$ sec and $T_y=0.26$ sec, i.e. in fairly good agreement with those evaluated experimentally.

Technical Chamber of Greece building, Patras. After a M6.5 mainshock on June 6, 2008 at a distance of approximately 35 km southeast of the city of Patras, ITSAK researchers instrumented the five-story R/C building of the Technical Chamber of Greece (Figure 22a). A 19-bit special array was used, together with 12 uniaxial accelerometers and a 200sps sampling rate (Figure 22b).

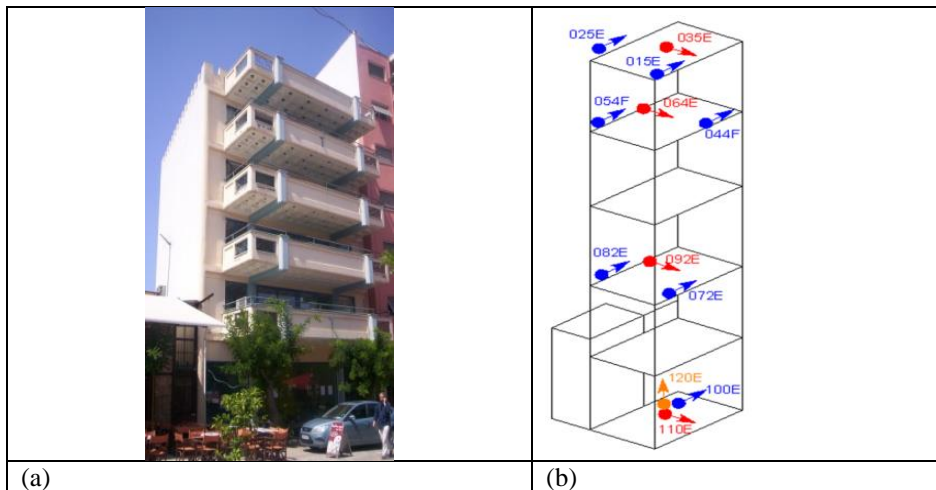

Figure 22. (a) The Technical Chamber of Greece building at Patras (b) instrumentation layout

During its instrumentation, the building was subjected to an earthquake on 26/9/2003, which allowed the estimation of its dynamic characteristics (fundamental modes) through a PSD-based methodology (Makarios et al., 2009).

Administration building of Lixouri Hospital, Cephalonia island. In 2014, the island of Cephalonia, Greece was struck by two major earthquakes: a M6.1 on 26/1/2014 and a M6.0 on 3/2/2014. During these events (PGA=0.54g and 0.68g respectively at Lixouri) the administrative building of the hospital in the town of Lixouri (Figure 23) building (designed according to the 2003 Seismic code for a design PGA=0.36g) behaved exceptionally well. Essentially no damage to neither its load bearing structural system nor the infill walls' bricks and plaster occurred. For this reason it was decided to monitor the building. On February 5, 2014 ITSAK instrumented with a special 24-bit accelerometer array with 9 uniaxial sensors.

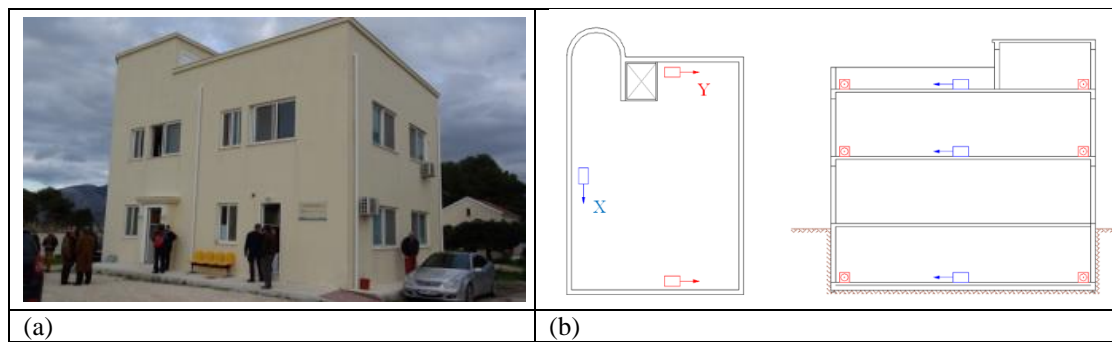

Figure 23. (a) The instrumented administrative building of Lixouri Hospital (b) instrumentation layout

The response of the building recorded during various aftershocks (82 events were recorded) was used to assess its actual dynamic characteristics (eigenvalues, eigenmodes, damping ratios). These were then used to calibrate finite element models of the structure that were developed in order to reliably represent its actual dynamic behavior. The updated F.E. models were used to compute the maximum story drifts during the two aforementioned major events through time-history analyses, and to explain the lack of any damage to the building. The ratios of the peak values at the top and basement of the building were also used to validate the corresponding values of the spectral amplification factors (β) adopted by the Greek Seismic Code (EAK/2003) for the specific soil type at the site and building's period. The experimentally mean computed amplifications were higher than the ones of the Code, with the latter, however, in general lying within the mean-1 Standard Deviation range of the recorded amplifications. A detailed presentation of the research results is presented in Karakostas et al., 2016.

Municipality Building, Lefkada island. The building of Municipality of the town of Lefkas (Figure 24) was instrumented in 2012 by EPPO-ITSAK with a special 24-bit resolution accelerometer array comprising twelve uniaxial accelerometers. Since its installation, several earthquakes have been recorded by the special array, and a major (M6.1, on 26-1-2014) earthquake excitation was used to evaluate the dynamic response of the building.

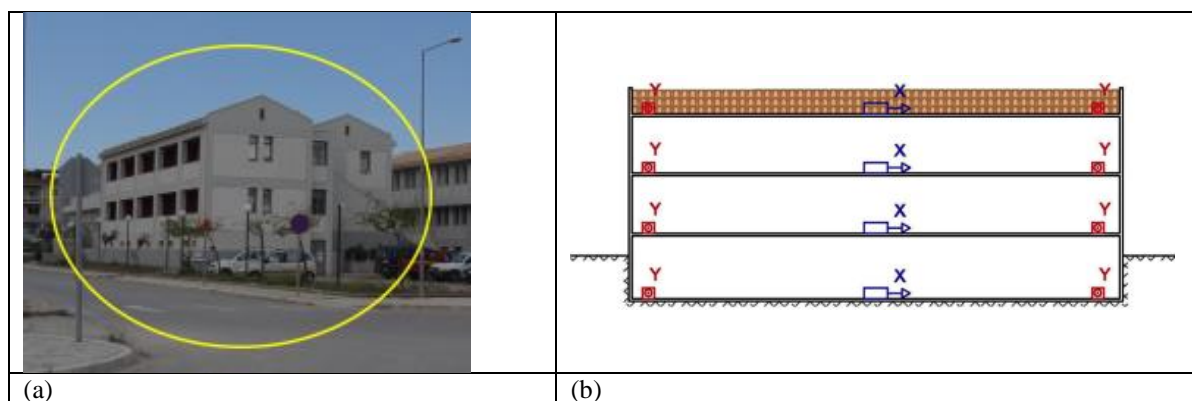

Figure 24. (a) Lefkada Municipality building (yellow ellipse) and location of the free-field accelerometer (yellow arrow) (b) instrumentation layout

Also, at a distance of around 40 m from the building, a free-field triaxial sensor was installed in 2013. Its recordings were compared to those of the special array at the basement of the instrumented building, and an investigation of the SSI effects was conducted, in order to justify the discrepancies (both in the time and frequency domain) observed between recordings at the free-field site and the base of the building (Karakostas et al., 2018).

Kalochori Accelerometric Network (KAN). Two buildings and one steel water tank have been instrumented since 2014 in the urban area of Kalochori, near Thessaloniki, as part of the Kalochori Accelerometric Network (Rovithis et al. 2018). The instrumentation refers to a pair of triaxial accelerometric stations; one installed on top of the structure and one on the ground surface at a close distance from the structure's base (Figure 25).

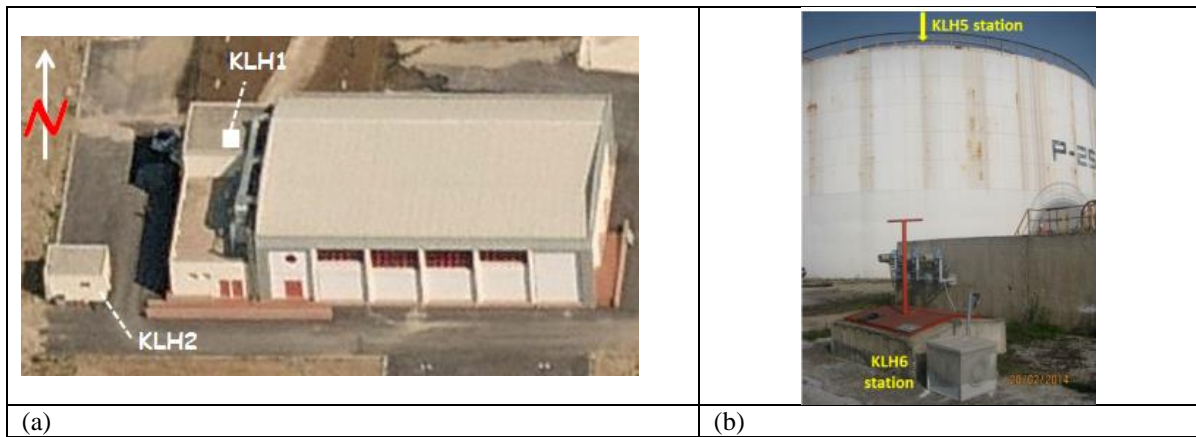

Figure 25. (a) The municipal gymnasium building (Bing Maps Image) and (b) the steel water tank located in the broader urban area of Kalochori, west of Thessaloniki. The locations of the accelerometric stations are also shown.

A set of 78 earthquakes has been recorded by KAN between 01/16/2014 and 12/31/2016, allowing the investigation of possible urban effects on ground motion and the evaluation of dynamic response features of the instrumented structures including soil-structure interaction (Kirtas et al. 2018). The complete set of KAN stations data and earthquakes recordings are available through the Web-GIS portal: <http://apollo.itsak.gr/apollo-portal/ApolloPro.aspx> while the DOI linked to the above data is 10.6084/m9.figshare.5044804.

Instrumented Bridges

Chalkis Cable-Stayed bridge. In 1994 ITSAK instrumented the 395m long Cable-Stayed section of the bridge at Evripos Channel, Greece (Figure 26a), with a permanent accelerometer network of 42 sensors supported by three interconnected 12-bit recording units (Figure 26b). In 2012 the system was upgraded with a new 36-channel, 24-bit recording station that also allowed real time telemetry over Ethernet.

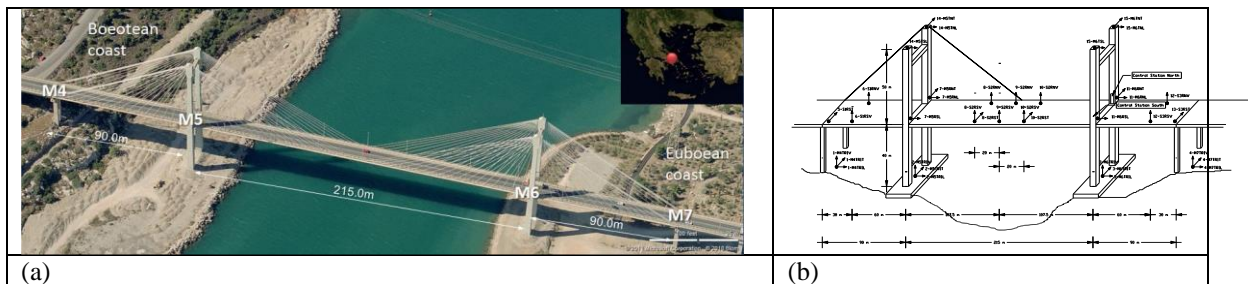

Figure 26. (a) The Cable-stayed section of the Evripos Channel bridge (b) instrumentation layout

Several earthquake events were recorded by the system, which were used for the experimental assessment of the dynamic characteristics of the bridge (Lekidis et al., 1998, 2001). A methodology for updating the F.E. model of the bridge based on its recorded seismic response is presented by Papadimitriou et al., 2002. In Lekidis et al., 2005 is presented a study on the effect of local soil on the variation of the ground motions at the bridge's supports and on the structure's response. The investigation is based on recordings from both the permanent accelerometer array and an additional geodetic system. Finally, an investigation of the dynamic response of the bridge under the asynchronous ground motions recorded by the accelerometer array is presented in Karakostas et al., 2011, Papadopoulos et al., 2013 Lekidis et al. 2013 and Sextos et al., 2015.

Kavala and Polymylos bridges at Egnatia Motorway. Egnatia Motorway is a 670km long highway, that crosses Northern Greece in the E–W direction. ITSAK, in collaboration with the Bridge Maintenance Dpt. of Egnatia Odos S.A., instrumented two R/C bridges, namely the 2nd Kavala Bypass Ravine Bridge and the 9th Ravine Bridge on the Veria - Polymylos section (Figure 27). Both bridges have two, almost identical, statically independent lanes, one for each traffic direction. For both bridges only one lane was instrumented.

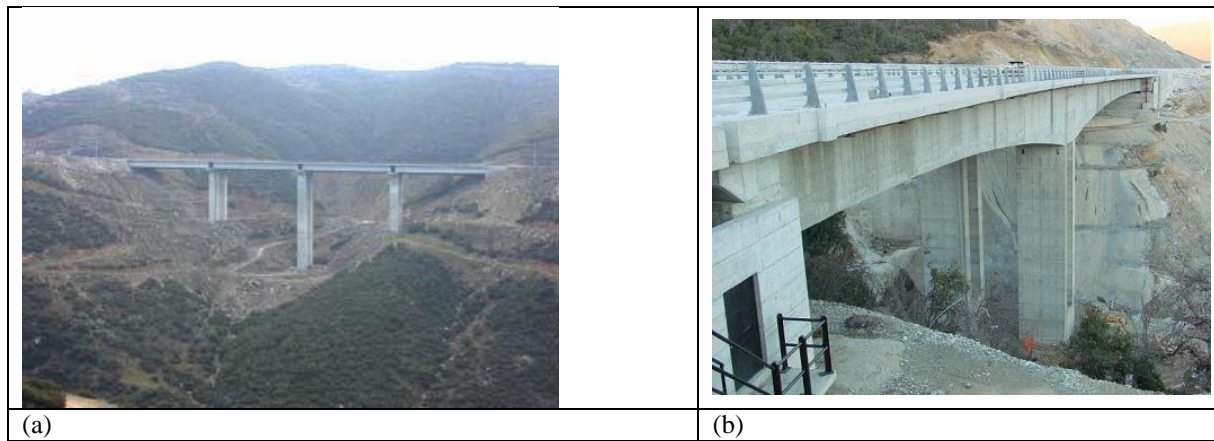

Figure 27. Instrumented bridges by ITSAK and Egantia Odos S.A. (a) the Kavala bridge (b) the Polymylos bridge

Several ambient noise measurements as well as earthquake excitations were recorded, and they were used for the identification of the dynamic characteristics of the bridges (Lekidis et al., 2004, Ntotsios et al., 2009), as well as the updating of F.E. models (Pavlidou et al., 2002, Karamanos et al., 2004). Methodologies for the computation of vulnerability curves for the two bridges are presented in Karakostas et al., 2006 and Makarios et al., 2007. It has to be noted that the Bridge Maintenance Dpt. of Egnatia Odos S.A. monitors several other bridges along the Egnatia motorway with a custom-developed bridge management system (Panetsos et al., 2006).

Seismic SHM and testing for cultural heritage in Portugal

In the last years, the employment of Structural Health Monitoring (SHM) tools in support of the dynamic characterization and condition assessment of the existing built environment has earned a wide consent in Portugal, especially when dealing with strategic structures and infrastructures systems. The great interest that SHM has received from both the scientific and professional sectors is essentially due to the unquestionable advantages that vibration-based structural monitoring procedures offer in terms of modal feature extraction, characterization of the global structural behaviour, rapid condition screening, identification of anomalies and damage mechanisms, evaluation of operational and environmental effects, assessment of strengthening needs, validation of structural interventions and calibration of realistic numerical models for structural analyses. Yet, the possibility to continuously track the structural health of the system under observation without resorting to any invasive technique has further encouraged the application of SHM to historical constructions and monuments, despite the numerous challenges associated with such complex and unconventional artefacts. Trying to cover emblematic examples of SHM over the Portuguese territory, the following applications can be mentioned: Pedro e Inês footbridge (Caetano et al., 2010), Braga Stadium suspension roof (Martins et al., 2014), Foz Tua centenary railway bridge (Magalhães et al. 2016), Infante D. Henrique bridge (Magalhães et al. 2012), Mogadouro clock tower (Ramos et al. 2010), Jeronimos church (Masciotta et al., 2016), Saint Torcato church (Masciotta et al., 2017), Baixo Sabor arch dam (Pereira et al., 2017), Foz Côa church (Mesquita et al., 2018).

SHM systems also result particularly attractive for advanced seismic protection of critical structures located in earthquake-prone areas, given their potential for real-time structural assessment and early warning of seismic damage. Strong ground motions can trigger major damages and collapses, but repeated earth-shakings of small or medium intensity can cause cumulative damages which are often not directly detectable by visual inspections. Hence, the employment of reliable SHM tools in the early post-earthquake phase is fundamental to spot damages that lie unseen beneath the surface of the structure and to track the evolution of ongoing mechanisms in order to safely manage rescue operations and support civil protection activities. The added value that SHM-weighted information can bring to both stages of event preparedness and event response is doubled in case of ancient constructions, as none of them meet earthquake design requirements nor comply with any particular design code (Lourenço et al., 2013).

Ranked as one of the oldest countries in the world, Portugal features a large number of age-old structures which are all potentially exposed to both inland and offshore earthquakes, being the country located near the Eurasia-Africa plate boundary, opposite the Atlantic Ocean. One of the largest ever recorded earthquakes to impact Europe was indeed the 1755 Lisbon Earthquake, which also triggered an enormous tsunami in the North Atlantic Ocean. After such a destructive event, Lisbon metropolitan area was rebuilt according to anti-seismic provisions and great efforts have been made since then to reduce the seismic risk of building stock across the territory. Nevertheless, built heritage still represents an important part of this building stock. The well-known seismic vulnerability of existing historical constructions, combined with all the uncertainties that still arise on their actual structural behaviour, continues to promote investigations aimed at improving SHM-based condition assessment procedures, while shedding light on the seismic response of such systems. The following sections discuss the operational framework adopted in Portugal for the rapid condition screening of heritage structures in the context of seismic risk prevention. Because of space limitations, only a concise description of a few emblematic examples is presented hereafter.

Operational framework for rapid condition screening of heritage structures

Due to the seismotectonic characteristics of the region, the seismic hazard maps of mainland Portugal forecast two scenarios (NP EN 1998): severe magnitude events at long distances with offshore epicentres (Type 1 seismic action) and moderate magnitude events at short distances with inland epicentres (Type 2 seismic action). In either case, apart from the Lisbon and Algarve regions, the seismicity of the Portuguese continent is rather low when compared to the rest of Europe (Figure 28), being the reference PGA lower than 0.125g in great part of the Country. Nevertheless, repeated moderate earthquakes can be particularly harmful to centuries-old constructions, being cause of cumulative damages which can further increase their structural vulnerability. Depending on their specific structural characteristics, buildings can experience a considerable degree of loss for low input intensities and vice versa. Indeed, the seismic risk is determined by the combination of hazard, vulnerability and exposure.

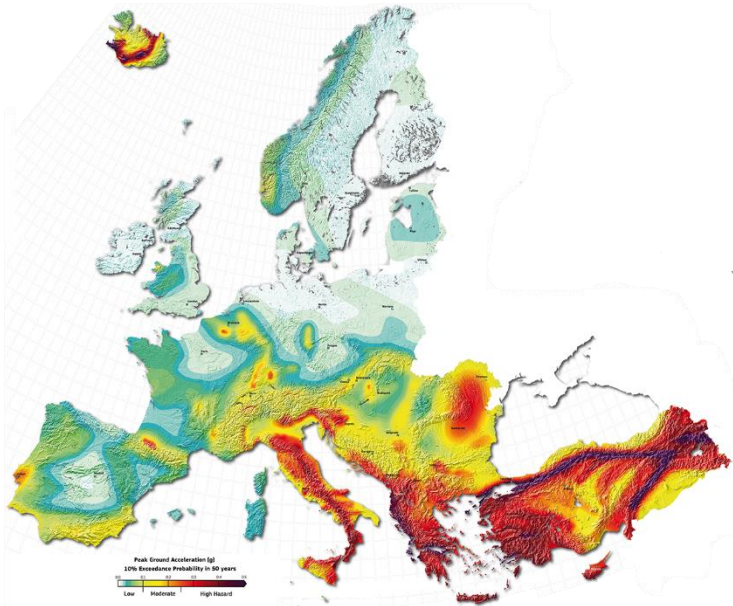

Figure 28. – Europe seismic hazard map (source: www.seismo.ethz.ch).

in the context of heritage preservation and seismic risk reduction, the University of Minho is engaged in various monitoring activities and investigations aimed at improving SHM-based condition assessment procedures, while shedding light on the seismic behaviour of non-conventional historic structures. Three relevant examples will be presented in this paper with the purpose of giving a brief insight into the *modus operandi* adopted for tracking the dynamic behaviour of heritage buildings over time and assessing their health conditions in pre- and post-seismic scenarios.

In most cases, a simplified layout consisting of two tri-axial force-balance accelerometers, one installed at the ground level and another on top of the structure, is adopted for permanent monitoring systems. Although a higher density of sensors would be preferable to fully describe the dynamic behaviour of complex heritage buildings, this number of accelerometers is considered sufficient enough for a rapid and low-cost global assessment of the structural conditions, enabling also to account for the amplification of the structural response in case of seismic event.

The installed accelerometers typically feature a dynamic range of ± 1.0 g, a sensitivity of 10 V/g and a temperature range between -20°C and 70°C , where the operating ranges are set according to the local seismic hazard and environmental conditions. Each sensor is connected by cable to a strong motion recorder provided with an integrated 16-bit or 24-bit ADC (Analog-to-Digital Converter). The recorder at the ground level is the master recorder, while the recorder at the top level is the slave recorder. Both recorders have the same capabilities but work independently. Still, they communicate through an enhanced interconnection network which enables synchronization and allows to set a common trigger. The system is conceived in such a way that, if more recorders are added, the same network can be easily extended to the new apparatus. Whenever the amplitude level of the monitored structure exceeds a predefined threshold value, the recorders are activated and the dynamic response at the instrumented locations is measured. To comply with the acquisition time length requirements, the total duration of the dynamic recordings is never lower than 1000-2000 times the structure's fundamental period (meaning around 9-17 minutes for a building with $T_1 = 0.5\text{s}$). Moreover, depending on the frequency content of the monitored structure, the sampling rate for the signal acquisition may vary between 100 Hz and 200 Hz. To detect frequency shifts and separate the influence of environmental conditions, monthly and seasonal programmed events are also recorded. Indeed, subtle changes caused by damage in masonry structures may be often masked by changes due to varying ambient conditions. It is worth noting that changes in the frequency-temperature relationships of the principal vibration modes of the structure may also take place after the occurrence of seismic events. Hence, it is common practice

in Portugal to couple SHM with the analysis of the environmental variability for a thorough assessment of the system's behaviour.

Any heritage structure is the result of different building phases, construction techniques and changes which have followed over time up to the present state. Therefore, before deploying the SHM system, historical analyses, surveys and preliminary in-situ diagnostic investigations are carried out to collect meaningful information about the geometrical and mechanical properties of the structure under observation as well as about possible local defects and vulnerabilities. Then, this information is combined with the results from ambient vibration tests (AVTs), allowing to set tailored acquisition parameters for the permanent monitoring system and to calibrate a reference FE model for assessing and comparing the seismic performance of the monitored structure in case of earthquake.

Instrumented buildings and data analysis

Noteworthy examples of heritage monumental structures currently monitored by the University of Minho are the Clock tower of Mogadouro, the Church of Saint Torcato and the Church of Jerónimos Monastery in Lisbon. After a first phase of data collection, including historical information, geometrical and topographic surveys, in-situ diagnostic investigations and AVTs, simplified SHM systems consisting of a limited number of accelerometers have been installed in the three monuments along with temperature/humidity sensors plus crack meters and tilt meters at critical locations. Data are acquired periodically for programmed and triggered events.

Built in the XVI century to serve the neighboring church as a bell tower, the *Mogadouro clock tower* is a historic granite masonry structure with a rectangular cross section of $4.7 \times 4.7 \text{ m}^2$ and a height of 20.4 m (Figure 29). The walls feature 1 m thickness, being their central part made of rubble stones with thick mortar joints and the corners built of large granite units with dry joints. Although located in a region with low seismic hazard, the tower's vulnerability before consolidation works was high. Thus, in 2006 the structure was equipped with a low-cost permanent monitoring system composed of three piezoelectric accelerometers placed at opposite corners at about mid height of the tower (Figure 29). This sensor layout was chosen based on the outcome of previous AVTs in order to ensure the tracking of the first five vibration modes, including the torsional mode. The accelerometers are connected by coaxial cables to a USB data acquisition card with 24-bit resolution, provided with anti-aliasing filters, which is connected to a laptop with an uninterruptible power supply device. LabView software is used to record and acquire the signals through an *ad hoc* Virtual Instrument (VI). Besides triggered events, the VI is programmed to acquire 10 minutes of ambient vibrations in the 3 channels every hour. In parallel, a combined sensor connected to the laptop through a serial cable records ambient temperature and relative air humidity.

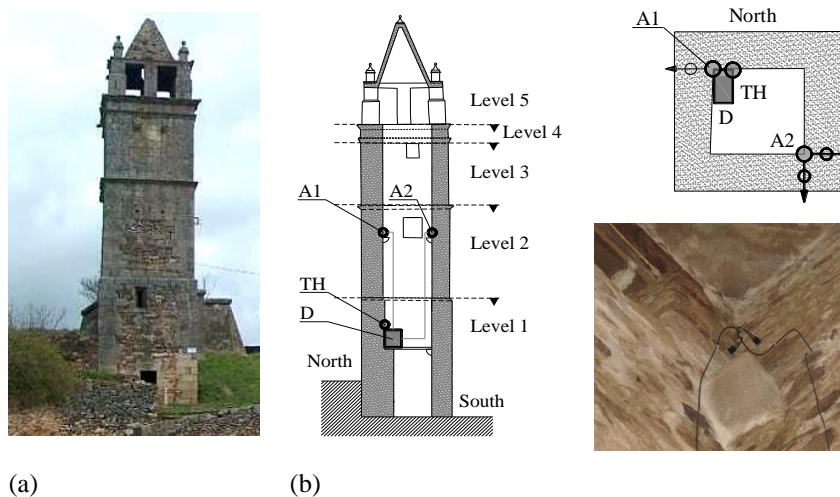

Figure 29. – Mogadouro Clock tower: (a) view of the structure; (b) SHM sensors deployment.

Saint Torcato church is a Neo-Manueline temple located in the homonymous village, North of Portugal. The church is characterized by a Latin cross longitudinal plan with a central nave of nearly 58 m length and a transept of about 37 m length, both covered with a barrel vault. The crossing between longitudinal nave and transept is capped with a dome. Two spired towers with rectangular section frame the façade (Fig. 3a-b). The construction of the church started in 1825 and stretched over nearly two centuries, involving several building phases and different materials. Towers and nave are made of three-leaf walls consisting of outer regular granite masonry blocks with thin mortar joints and inner rubble core, whereas apse and main altar are built by reinforced concrete walls covered with granite veneer (Masciotta et al. 2017).

The church is located in a region with low seismic hazard, but the stratigraphy of the soil beneath together with the structural damage that the fabric suffered over time increase its vulnerability against horizontal actions. The temple stands on a slope which is levelled by a landfills bank, thus the steady bedrock layer is very close to the foundation in the apsis and transept areas, but it goes deeper and deeper while proceeding towards the front of the temple. Here the soil is mostly composed of sands and non-cohesive layers, whose poor mechanical characteristics get worse when approaching the area below the western tower. This caused differential settlements in the strata underlying towers and façade, leading to separation movements of the towers and a severe V-cracking pattern in the façade (Figure 30c-d).

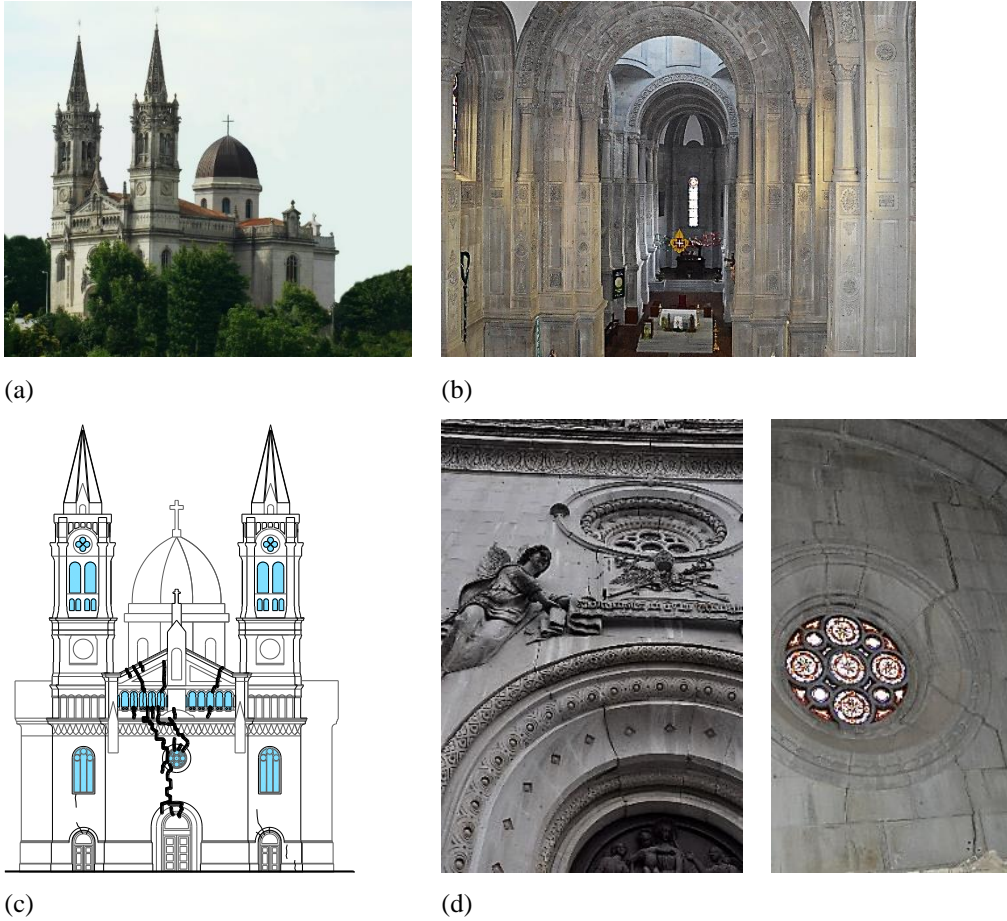
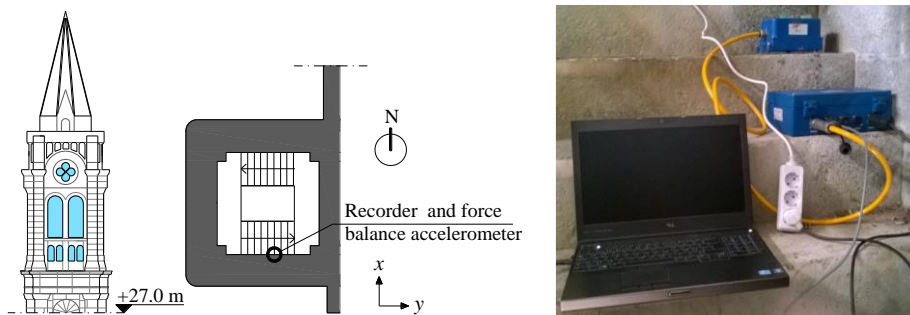

Figure 30. – Saint Torcato church: (a) exterior view of the building; (b) interior of the church; (c) and (d) damage pattern before consolidation.

After a long-term static and dynamic monitoring, strengthening works were carried out in 2014-2015 aiming at eliminating differential soil settlements and restraining the towers leaning. The Church appears now in sound state, however since 2014 a simple permanent SHM system for quick condition screening has been installed on top of the western tower, namely the one exhibiting higher tilting (Figure 31). The system consists of one strong motion recorder with 16-bit ADC and one tri-axial force balance accelerometer with a dynamic range of ± 1 g and a sensitivity of 10 V/g. The vibration response of the structure is recorded for both triggered and programmed events. As the mode shapes of interest of the church are those associated with the towers' movements, whose frequencies fall within the range 2-3 Hz according to the former AVTs (Ramos et al. 2010), signals are acquired for 600s with a sampling frequency of 100 Hz.



(a)

(b)

Figure 31– SHM system of Saint Torcato church: (a) location of the devices; (b) setting of accelerometer and strong motion recorder on top of the western tower.

The Church of “*Santa Maria de Belém*” is a limestone masonry structure built during the XVI century and located inside the majestic Monastery of Jerónimos in Lisbon, one of the regions with the highest seismic hazard in Portugal. The church features a cruciform shape with a single nave of 70 m length crossed by a transept of 40 m width, and an average height of 24 m. A single bell tower of 50 m height rises in the corner between south and west façades. Two rows of slender octagonal columns with a free height of 16 m and a radius ranging from 1.04 m to 1.88 m provide support to the barrel vault of the longitudinal limb, allowing to reduce the large free span of the nave (Figure 32) The seismic performance of the structure during the strong earthquake of 1755 was impressive. No severe damage was registered in that occasion in the whole compound. On the contrary, the subsequent shake of 1756 caused the collapse of one of the columns supporting the vaults of the church (with subsequent ruin of the nave) and also the partial collapse of the vault of the higher choir (Lourenço et al. 2007, Masciotta et al., 2016). Following these events, during the XIX century changes were made in the structure of the two towers and in the roof. The effect of these changes on the seismic performance of the structure remained an open issue (Lourenço et al. 2007). Hence, several studies and numerical simulations have been performed in the last decades to investigate the structural behaviour of this church (Lourenço et al. 2007, Oliveira et al. 2005). In addition, to keep under control the health state of the monument and mitigate the seismic risk, a simplified monitoring system has been installed in the church since 2005. The type and location of sensors have been chosen according to the features to be extracted and in conformity with the directions of IGESPAR, former IPPAR (Portuguese Authority for the Architectural Heritage), with the purpose of minimizing the visual impact of the systems in the church (Masciotta et al. 2016).



(a)



(b)

Figure 32 – Church of Jerónimos Monastery: (a) exterior view; (b) nave ribbed vault.

The SHM system is composed of two strong motion recorders and two tri-axial force balance accelerometers (Figure 33a-b), one (A1) located at the base of the structure near the chancel and connected to the master recorder, and the other one (A2) installed on the nave extrados and connected to the slave recorder. The recorders are mutually interconnected and synchronized for both triggered and programmed events. A predefined amplitude threshold of 0.5 mg is set in all 3 directions for the sensor at the base. As for the sensor at the nave extrados, thresholds of 1 mg and 5 mg are assigned in x (longitudinal) and y/z (transversal/vertical) directions, respectively. Anytime the amplitude level of the signals exceeds the predefined thresholds, data are recorded and stored to a permanent memory. Besides, monthly and seasonal programmed events of 10 minutes are registered to follow frequency trends over time and separate possible environmental fluctuations. According to the results of previous Operational Modal Analysis (OMA), the sampling rate adopted for digitizing the signals is 100 Hz for all events. On 12 February 2007 at 10:35 am, a moderate earthquake of magnitude $M_w = 6.1$ and with epicentre offshore Southwest Iberia occurred. The Monastery felt the ground shaking and its response was acquired by the strong motion recorders installed in the church (Figure 33c-d). No severe damage took place, but a slight drop in the modal frequencies as well as a change of the frequency-temperature correlation were observed after the occurrence of the seismic event.

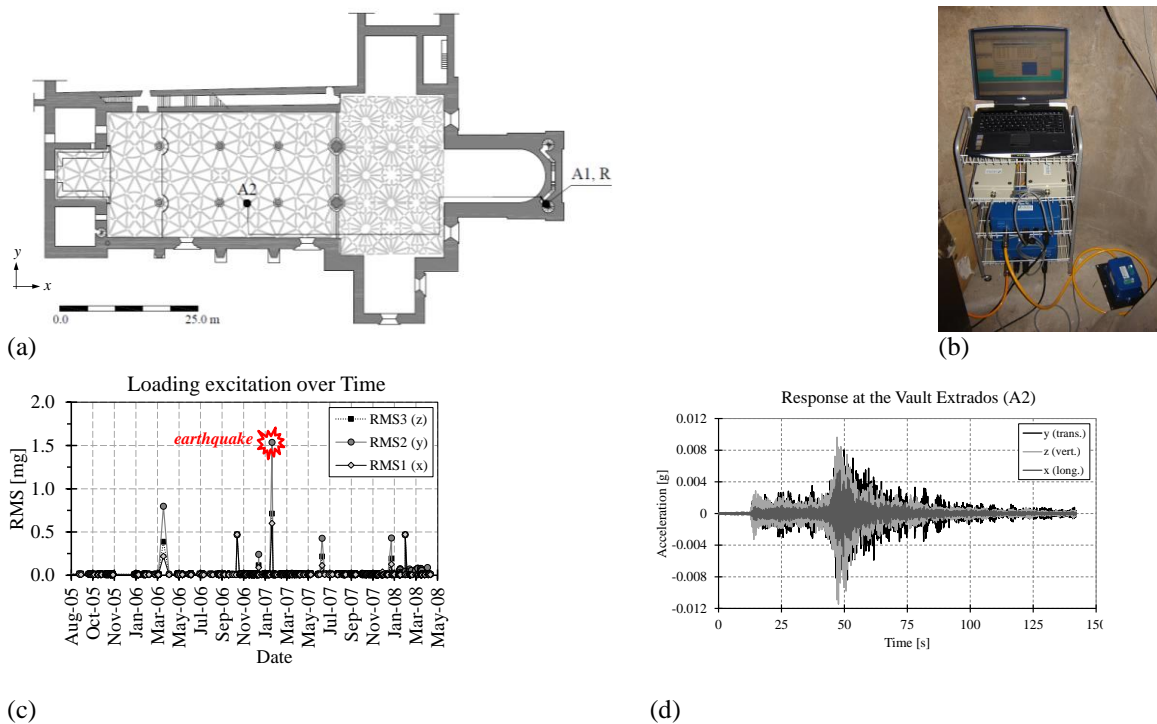

Figure 33 SHM system of the Church of Jerónimos Monastery: (a) sensors location; (b) battery of recorders and accelerometer at the base level; (c) ambient excitation before, during and after the earthquake of 12/02/2007; (d) response of the church at the vault extrados during the seismic event.

The data recorded by the SHM systems installed on the monitored heritage structures are automatically processed in order to perform a rapid condition screening of the system's health. The automatic procedure is carried out through a MatLab algorithm based on the Stochastic Subspace Identification method (SSI-data driven) (Peeters and De Roeck, 1999). Control parameters and threshold values are established beforehand to avoid unrealistic estimations. The automatic process includes the extraction of modal features, the calculation of the spectral acceleration of the building in the three spatial directions and the estimation of global damage-sensitive parameters to carry out a first rough damage assessment. If the estimated frequency shifts do exceed the confidence limits established around each predicted value, more accurate analyses are carried out for locating and quantifying the damage. This might include either modal-based inverse approaches such as Vibration-based Damage Identification Methods (VBDIMs) or model-based inverse approaches like the Finite Element Model Updating (FEMU).

Conclusions

In this paper a summary of the seismic SHM applications to civil structures in different European countries is reported. Several examples of instrumented buildings, bridges and cultural heritage constructions are shown. In Italy, France and Greece national programs supported by local public bodies are organized for civil protection activities. Data recorded by the monitoring systems are used for condition assessment, damage detection and emergency management and constitute the base for the scientific community to improve the understanding of the structural behavior during strong motions and sequences of events with variable intensity. Data recorded under low intensity ambient vibration are also used to calibrate and update finite element models for long term-assessment of the structural conditions and damage detection connected with a rapid condition screening of the system health.

Acknowledgements

RESIF is a national research infrastructure managed by the RESIF Consortium, composed of 18 research institutions and universities in France. RESIF is also supported by a public grant, supervised by the French national research agency (ANR) as part of the "Investissements d'Avenir" programme (reference: ANR-11-EQPX-0040) and the French Ministry for an Ecological and Solidary Transition. RAP national building array programme was launched thanks to funding from the environment ministry, Martinique regional council, Grenoble city council and the Pyrenees regional agency for development (DDT65).

During its research efforts, ITSAK has collaborated with various scientists from the Civil Engineering Dpts. of the Aristotle University, the Dpt. of Mechanical and Industrial Engineering, University of Thessaly, Volos, the and the Bridge Maintenance Dpt. of Egnatia Odos S.A. Their particular contributions are noted in the respective literature. Many thanks are also due to the Institute's technical staff, for their invaluable contribution in the instrumentation efforts and the proper maintenance of the electronic equipment.

References

- Acunzo G., S. Gabriele, D. Spina, C. Valente, MuDI: A Multilevel Damage Identification Platform, Proceedings of the twelfth International Conference on Computational Structures Technology, Paper 10.123 from CCP: 106, ISBN 978-1-905088-61-4 (2014).
- Brossault, M.B., Roux, P., and Guéguen, P. (2018). The fluctuation–dissipation theorem used as a proxy for damping variations in real engineering structures. *Engineering Structures* 167,65-73.
- Caetano, E., Cunha, A., Magalhães, F., and Moutinho, C. (2010). Studies for controlling human-induced vibration of the Pedro e Inês footbridge, Portugal. Part 1: Assessment of dynamic behaviour. *Engineering Structures* 32, 1069–1081.
- Dolce M., G. De Canio, A. Goretti, R. Marnetto, M. Nicoletti, D. Cardone, C. Moroni, D. Nigro, F. C. Ponzo, N. Ranieri, E. Renzi, D. Spina, SICURO and TREMA Projects: the seismic performance of R/C frames seismically upgraded with different systems, 2nd International FIB Congress, June 5-8, 2006, Naples.C.
- Dolce M., F.C. Ponzo, A. Goretti, C. Moroni, F. Giordano, G. De Canio, R. Marnetto, 3D Dynamic test on 2/3 scale masonry buildings retrofitted with different systems, Proceeding do 14th Word Conference on Earthquake Engineering, Beijing, China, October 12-17 2 M. 008.
- Dolce, M. Nicoletti, A. De Sortis, S. Marchesini, D. Spina, F. Talanas, Osservatorio sismico delle strutture: the Italian structural seismic monitoring network, *Bulletin of Earthquake Engineering* 15, pp. 621-641 (2017)
- Eurocode 8 (2004, 2005). Design of structures for earthquake resistance - Part 1: General rules, seismic actions and rules for buildings (EN 1998-1). Part 3: Assessment and retrofitting of buildings (EN 1998-3), European Committee of Standardization Brussels, Belgium.
- Fernando-Lorenzo, G. (2016). From accelerometric records to the dynamic behavior of existing buildings. PhD dissertation, Université de Nice Sophia Antipolis.
- Giordano P.F., Miraglia S., Limongelli M.P. (2018) The value of information for the seismic emergency management of a highway bridge. Innovative Industry Workshop. COST Action TU1402. April 2018, Lisbon.
- Guéguen, P. (Editor) (2013). Seismic vulnerability of structures, Civil Engineering and geomechanics series, John Wiley and Son (Hoboken USA) and ISTE (London, UK) editor, 368 pages
- Guéguen, P. (2012). Experimental analysis of the seismic response of an isolated building according to different levels of shaking: example of the Martinique earthquake (2007/11/29) Mw 7.3. *Bull Earthq. Engng.* 10(4), 1285-1298.
- Guéguen, P., Langlais, M., Garambois, S., Voisin, C., and Douste-Bacqué, I. (2017). How sensitive are site effects and building response to extreme cold temperature? The case of the Grenoble's (France) City Hall building. *Bulletin of Earthquake Engineering*, 15(3): 889-906.
- Karakostas, C.Z., Lekidis, V.A., Pavlidou M. and Papadimitriou K. (2002) Analytical and Experimental Investigation of the Dynamic Behaviour of R/C Buildings during the Athens (7-9-99) Aftershock Sequence. *Proceedings of the 12th European Conference on Earthquake Engineering (12ECEE)*, London, Sept. 9-13, paper no. 270.
- Karakostas, C.Z., Lekidis, V.A. and Papadimitriou K. (2003) Seismic Response of instrumented R/C Buildings during the Athens (7-9-99) Aftershock Sequence. *Proceedings of the fib-Symposium on Concrete Structures in Seismic Regions (FIB2003)*, Athens, Greece, May 6-9, paper no. 113.
- Karakostas, C., Makarios, T., Lekidis, V. and Kappos, A. (2006) Evaluation of Vulnerability Curves for Bridges – A Case Study. *Proceedings of the 1st European Conference on Earthquake Engineering and Seismology*, Geneva, September 3-8, paper no.1435.
- Karakostas, C., Sextos, A., Lekidis, V. and Papadopoulos, S. (2011) Investigation of the dynamic response of the Evripos cable-stayed bridge in Greece under asynchronous ground motion records. *Proceedings of Computational Methods in Structural Dynamics and Earthquake Engineering (COMPADYN2011)*, Corfu, Greece, May 25-28, paper No. 486.

- Karakostas, C., Lekidis, V., Morfidis, K. and Salonikos, Th. (2016) Investigation of the dynamic response of an instrumented building during the Cephalonia 2014 Seismic Sequence. *Proceedings of the 17th National Reinforced Concrete Conference*, Thessaloniki, Greece, November 10-12, paper no. 35. (in Greek)
- Karakostas, C., Rovithis, Em., Morfidis, K., Chatzistefanou G.A., Lekidis, V. Theodoulidis N. and Makarios T. (2018) Investigation of the Dynamic Response and SSI effects of the Instrumented Municipality Building in Lefkas, Greece. *Proceedings of the 16th European Conference on Earthquake Engineering*, Thessaloniki, Greece, June 18-21, paper no. 11461.
- Karamanos, S.A., Papadimitriou, C., Christodoulou, K., Karakostas, C.Z., Lekidis, V.A. and Panetsos, P. (2004). Multi-Objective Framework for Model Updating with Application to a Four-Span Concrete Bridge. *Proc. 2nd European Workshop on Structural Health Monitoring, C. Boller and W.J. Staszewski (Eds)*, Munich, July 7-9, DEStech Publications, pp. 195-202.
- Kirtas, Emm., Rovithis, Emm., Makra, K. and Papaevangelou, I. (2018) Dynamic response characteristics of an instrumented steel water tank in Kalochori, N. Greece. *Proceedings of the 16th European Conference on Earthquake Engineering*, Thessaloniki, Greece, June 18-21, paper No. 11167.
- Larose, E., Carrière, S., Voisin, C., Bottelin, P., Baillet, L., Guéguen, P., Walter, F., Jongmans, D., Guillier, B., Garambois, S., Gimbert, F., and Massey, C. (2015). Environmental Seismology : what can we learn on Earth surface processes with ambient noise ? *Journal of Applied Geophysics* 116, 62–74.
- Lourenço P.B., Leite, J.M., Paulo-Pereira, M.F., Campos-Costa, A., Candeias, P.X., and Mendes, N. (2016). Shaking table testing for masonry infill walls: unreinforced versus reinforced solutions. *Earthquake Engineering & Structural Dynamics* 45, 2241–2260.
- Lourenço, P.B., Avila, L., Vasconcelos, G., Alves, P., and Mendes, N. (2013). Experimental investigation on the seismic performance of masonry buildings using shaking table testing, *Bulletin of Earthquake Engineering* 11(4), 1157–1190.
- Lekidis, V. A., Karakostas, C.Z. and Talaslidis D.G. (1998) Dynamic Characteristics of the Cable-Stayed Bridge on Evripos Channel, Greece. *Proceedings of the 11th European Conference on Earthquake Engineering, CNIT, Paris, France, September 6-11.*
- Lekidis, V. A., Karakostas, C.Z. and Talaslidis D.G. (2001) Instrumentation, Measurements and Numerical Analysis of Bridges : An Example of the Cable-Stayed Bridge on Evripos Channel, Greece *Proceedings of the Advanced NATO Workshop on Strong Motion Instrumentation for Civil Engineering Structures, M.Erdik et al. (eds.)*, Istanbul, Turkey, 1999, Kluwer Academic Publishers, 2001, 481-493.
- Lekidis, V.A., Karakostas, C.Z., Christodoulou, K., Karamanos S., Papadimitriou K. and Panetsos P. (2004) Investigation of Dynamic Response and Model Updating of Instrumented R/C Bridges. *Proceedings of the 13th World Conference on Earthquake Engineering (13WCEE)*, Vancouver, August 1-6.
- Lekidis, V., Tsakiri, M., Makra, K., Karakostas, C., Klimis, N., and Sous, I. (2005) Evaluation of Dynamic Response and Local Soil Effects of the Evripos Cable-Stayed Bridge using Multi-sensor Monitoring Systems. *Engineering Geology*, Vol. 79, pp.43-59
- Lekidis, V., Papadopoulos, S., Karakostas, C. and Sextos A. (2013) *Monitored incoherency patterns of seismic ground motion and dynamic response of a long cable-stayed bridge* Postconference book *Computational Methods in Earthquake Engineering*, Vol. 2, M.Papadrakakis, M. Fragiadakis, V. Plevris (Eds.), Chapter 2 in *Computational Methods in Applied Sciences*, Volume 30, 2013, pp.33-48
- Limongelli M.P., (2003), "Optimal location of sensors for reconstruction of seismic responses through spline function interpolation". *Earthquake Engineering and Structural Dynamics*, 32, pp. 1055-1074.
- Limongelli M.P. (2004). "Modeling of unknown seismic responses of a partially instrumented bridge structure" 13rd World Conference on Earthquake Engineering, Vancouver (Canada), 1-6 Agosto, 2004.
- Limongelli M.P. (2018). "Monitoraggio di edifici dotati di sistemi di isolamento e di sistemi dissipative" Research report project Reluis 2018. Unità PoliMI_Li
- Limongelli M.P., Iacovino C. , Ditommaso R., Ponzo F.C., (2019). Preliminary analysis of the dynamic behaviour of several structures subjected to the 2016 Central Italy earthquake. Submitted to SEMC 2019. Cape Town September 2019.
- Magalhães, F., Cunha, A., and Caetano, E. (2012). Vibration based structural health monitoring of an arch bridge: From automated OMA to damage detection. *Mechanical Systems and Signal Processing* 28, 212–228.
- Magalhães, F., Pacheco, J., and Cunha, A. (2016). Illustrating the relevance of SHM in a case study: the Foz Tua centenary railway bridge. *8th European Workshop on Structural Health Monitoring*, Jul. 5-8, Bilbao, Spain.

- Makarios, T., Salonikios, Th., Karakostas, Ch., Lekidis, V., Sous, I. And Anastasiadis, A. (2006). Assessment of Dynamic Characteristics of a R/C building through a Seismic Excitation Recording. *15th National Reinforced Concrete Conference*, Oct. 25-27, Alexandroupolis, Greece, Vol. B', 396-409 (in Greek)
- Makarios, T., Lekidis, V., Kappos, A., Karakostas, C., and Mochonas, J. (2007) Development of seismic vulnerability curves for a bridge with elastomeric bearings. *Proceedings of Computational Methods in Structural Dynamics and Earthquake Engineering (COMPDYN2007)*, Rethymno, Greece, June 13-16, paper No. 1516.
- Makarios, T., Salonikios, Th., Lekidis, V., Karakostas, Ch., and Demosthenous, M. (2009). Identification of eigen-periods & mode-shapes of vibration of a five-storey building by its response during the post-earthquake sequence of the Achaia-Illia earthquake. *16th National Reinforced Concrete Conference*, Oct. 21-23, Pafos, Cyprus (in Greek)
- Martins, N., Caetano, E., Diord, S., Magalhães, F., and Cunha, A. (2014). Dynamic monitoring of a stadium suspension roof: Wind and temperature influence on modal parameters and structural response. *Engineering Structures* 59, 80–94.
- Masciotta, M.-G., Ramos, L.F., and Lourenço, P.B. (2017). The importance of structural monitoring as a diagnosis and control tool in the restoration process of heritage structures: A case study in Portugal. *Journal of Cultural Heritage* 27, 36–47.
- Masciotta, M.-G., Roque, J.C.A., Ramos, L.F., and Lourenço, P.B. (2016). A multidisciplinary approach to assess the health state of heritage structures: The case study of the Church of Monastery of Jerónimos in Lisbon. *Construction and Building Materials* 116, 169–187.
- Mendes, N. (2012). Seismic assessment of ancient masonry buildings: shaking table tests and numerical analysis. PhD Thesis. University of Minho, Guimarães, Portugal.
- Mendes, N., and Lourenço, P.B. (2009). Seismic assessment of masonry “Gaioleiro” buildings in Lisbon, Portugal. *Journal of Earthquake Engineering* 14(1), 80–101.
- Mendes, N., Lourenço, P.B., and Campos-Costa, A. (2014). Shaking table testing of an existing masonry building: assessment and improvement of the seismic performance. *Earthquake Engineering & Structural Dynamics* 43, 247–266.
- Mesquita, E., Arêde, A., Pinto, N., Antunes, P., and Varum, H. (2018). Long-term monitoring of a damaged historic structure using a wireless sensor network. *Engineering Structures* 161, 108–117.
- Michel, C., and Guéguen, P. (2018). Interpretation of the velocity measured in buildings by seismic interferometry based on Timoshenko beam theory under weak and moderate motion. *Soil Dynamics and Earthquake Engineering* 104, 131–142.
- Michel, C., Guéguen, P. (2010). Time–Frequency Analysis of Small Frequency Variations in Civil Engineering Structures Under Weak and Strong Motions Using a Reassignment Method, *Structural Health Monitoring* 9(2), 159–171.
- Michel, C., Guéguen, P., El Arem, S., Mazars, J., and Kotronis, P. (2010). Full Scale Dynamic response of a RC building under weak seismic motions using earthquake recordings, ambient vibrations and modelling. *Earthq. Engng and Struct. Dyn.* 39, 419–441
- Mikael, A., Guéguen, P., Bard, P.-Y., Roux, P., and Langlais, M. (2013). Long-term frequency and damping wandering in buildings analysed using the Random Decrement Technique (RDT). *Bull seism. Soc. Am.* 103(1), 236-246.
- Mori F., G. Acunzo, N. Fiorini, A. Pagliaroli, D. Spina, M. Dolce, The SMAV (Seismic Model from Ambient Vibrations) methodology for the evaluation of the structural operativity of the buildings (in Italian), in: Proceedings of the XVI Congresso Nazionale “L’ingegneria Sismica in Italia” (ANIDIS2015), L’Aquila, Italy, 2015.
- Ntotsios, E., Karakostas, C., Lekidis, V., Panetsos, P. Nikolaou, I., Papadimitriou C. and Salonikios, Th. (2009) Structural identification of Egnatia Odos bridges based on ambient and earthquake induced vibrations. *Bulletin of Earthquake Engineering*, Volume 7, Issue2, 2009, pp. 485-501
- Nasser, F., Li, Z., Guéguen, P., and Martin, N. (2016). Frequency and damping ratio assessment of high-rise buildings using an Automatic Model-Based Approach applied to real-world ambient vibration recordings. *Mechanical Systems and Signal Processing*, 75, 196–208.
- Paquette, J., and Bruneau, M. (2006). Pseudo-dynamic testing of unreinforced masonry building with flexible diaphragm and comparison with existing procedures. *Construction and Building Materials* 20(4), 220–228.
- Papathoma-Köhle, M. (2016). Vulnerability curves vs. vulnerability indicators: application of an indicator-based methodology for debris-flow hazards. *Natural Hazards and Earth System Sciences* 16, 1771–1790.

- Panetsos, P., Lambropoulos, S., Papadimitriou, C., Karamanos, S., Lekidis V., and Karakostas, Ch. (2006) Bridge Health Monitoring for Egnatia Odos Bridge Management System *Proceedings of the 3rd European Workshop on Structural Health Monitoring*, Granada, Spain, July 5-7.
- Papadimitriou, C., Karamanos, S.A., Christodoulou, K., Pavlidou, M., Lekidis, V.A., Karakostas, C.Z. (2002) Model Updating of Bridges using Vibration Measurements. *Proceedings of the 12th European Conference on Earthquake Engineering (12ECEE)*, London, September 9-13, paper no. 485
- Papadopoulos, S., Lekidis, V., Sextos, A. and Karakostas, Ch. (2013) Assessment of EC8 procedures for the asynchronous excitation of bridges based on numerical analyses and recorded data. *Proceedings of Computational Methods in Structural Dynamics and Earthquake Engineering (COMPDYN2013)*, Kos, Greece, 12-14 June 2013, paper No 1498
- Papathoma-Köhle, M. (2016). Vulnerability curves vs. vulnerability indicators: application of an indicator-based methodology for debris-flow hazards. *Natural Hazards and Earth System Sciences* 16, 1771–1790.
- Paquette, J., and Bruneau, M. (2006). Pseudo-dynamic testing of unreinforced masonry building with flexible diaphragm and comparison with existing procedures. *Construction and Building Materials* 20(4), 220–228.
- Pereira, S., Magalhães, F., Gomes, J., Cunha, A., and Lemos, J.V. (2017). Installation and results from the first 6 months of operation of the dynamic monitoring system of Baixo Sabor arch dam. *Procedia Engineering* 199, 2166–2171.
- Pavlidou, M., Christodoulou, K., Gkaras, V., Karamanos, S.A., Papadimitriou, C., Perdikaris, P. Lekidis, V.A., Karakostas, C.Z. (2002) Model Updating of Bridges using Vibration Measurements. *Proceedings of the 1st European Workshop on Structural Health Monitoring (SHM2002)*, Paris, July 10-12, pp. 1107-1114
- Rovithis, Emm., Makra, K., Kirtas, Emm., Manesis, Ch., Bliziotis, D. and Konstantinidou, K., (2018) Field monitoring of strong ground motion in urban areas: the Kalochori Accelerometric Network (KAN), database and Web-GIS portal. *Earthquake Spectra* In-Press.
- Sextos, A., Karakostas, C., Lekidis, V. and Papadopoulos, S. (2015) Multiple support seismic excitation of the Evripos bridge based on free-field and on-structure recordings. *Structure and Infrastructure Engineering*, Vol. 11, No. 11, 2015, pp. 1510-1523 DOI: 10.1080/15732479.2014.977302
- Spina D., B.G. Lamonaca, M. Nicoletti, M. Dolce, Structural monitoring by Italian Department of Civil Protection and the case of 2009 Abruzzo seismic sequence, *Bulletin of Earthquake Engineering*, 9, pp 325-346 (2011)
- Ramos, L.F., Marques, L., Lourenço, P.B., De Roeck, G., Campos-Costa, A., and Roque J. (2010). Monitoring historical masonry structures with operational modal analysis: Two case studies. *Mechanical Systems and Signal Processing* 24(5), 1291–1305.
- Rytter T.: Vibration based inspection of civil engineering structure, PhD dissertation, Department of building technology and structure engineering, Aalborg University, Denmark, 1993.
- Valente, D. Spina, M. Nicoletti, Dynamic Testing and Modal Identification, in: *Seismic Upgrading of RC Buildings by Advanced Techniques*, Federico M. Mazzolani, Monza, 2006, pp. 29–101.
- Valente, D. Spina, M. Nicoletti, Dynamic Testing and Modal Identification, in: *Seismic Upgrading of RC Buildings by Advanced Techniques*, Federico M. Mazzolani, Monza, 2006, pp. 29–101.