



POLITECNICO
MILANO 1863

[RE.PUBLIC@POLIMI](#)

Research Publications at Politecnico di Milano

Post-Print

This is the accepted version of:

P. Di Lizia, F. Bernelli Zazzera, A. Ercoli Finzi, S. Mottola, C. Fantinati, E. Remeteian, B. Dolives
Planning and Implementation of the On-Comet Operations of the Instrument SD2 Onboard the Lander Philae of Rosetta Mission
Acta Astronautica, Vol. 125, 2016, p. 183-195
doi:10.1016/j.actaastro.2015.11.027

The final publication is available at <https://doi.org/10.1016/j.actaastro.2015.11.027>

Access to the published version may require subscription.

When citing this work, cite the original published paper.

© 2016. This manuscript version is made available under the CC-BY-NC-ND 4.0 license
<http://creativecommons.org/licenses/by-nc-nd/4.0/>

Permanent link to this version

<http://hdl.handle.net/11311/971544>

Planning and Implementation of the On-Comet Operations of the Instrument SD2 onboard the Lander Philae of Rosetta Mission

P. Di Lizia*, F. Bernelli-Zazzera, A. Ercoli-Finzi

*Department of Aerospace Science and Technology, Politecnico di Milano, Via La Masa
34, 20156 Milano, Italy*

S. Mottola

*Institute of Planetary Research, German Aerospace Center, Rutherfordstr. 2, D-12489
Berlin, Germany.*

C. Fantinati

Microgravity User Support Center, German Aerospace Center, Kln-Porz, Germany

E. Remeteau

*Space Robotics and System Validation Department, Centre National d'Etudes Spatiales
Bpi 1002, 18 av. E. Belin 31401 Toulouse Cedex 9, France*

B. Dolives

*Imaging and Applications Department, Magellium 24 Rue Herms, BP 12113, 31521
Ramonville Saint-Agne Cedex, France*

Abstract

The lander Philae of the Rosetta mission landed on the surface of the comet 67P/Churyumov-Gerasimenko on November 12, 2014. Among the specific subsystems and instruments carried on Philae, the sampling, drilling and distribution (SD2) subsystem had the role of providing in-situ operations

*Corresponding author. *E-mail:* pierluigi.dilizia@polimi.it

devoted to soil drilling, sample collection, and their distribution to three scientific instruments. After landing, a first sequence of scientific activities was carried out, relying mainly on the energy stored in the lander primary battery. Due to the limited duration and the communication delay, these activities had to be carried out automatically, with a limited possibility of developing and uploading commands from the ground. Philae's landing was not nominal and SD2 was operated in unexpected conditions: the lander was not anchored to the soil and leant on the comet surface shakily. Nevertheless, one sampling procedure was attempted. This paper provides an overview of SD2 operation planning and on-comet operations, and analyses SD2 achievements during the first science sequence of Philae's on-comet operations.

Keywords: 67P/Churyumov-Gerasimenko, Rosetta mission, Philae lander, SD2, Drilling, Sampling

1. Introduction

Comets are believed to contain the primitive leftovers of the solar system formation process. They carry records of the solar system in a very early phase and are a key to our understanding of its origin and development. Moreover, they contain information on the compositional mixture from which the planets formed about 4.6 billion years ago and are also known to harbour complex organic molecules, to the great interest of those who study the origins of life on Earth [18].

To date, the real nature of comets remains unknown and, over the last three decades, several space missions have pursued the task of approaching a comet for close investigation. The first probe to visit a comet was the ISEE-

3/ICE probe, which reached the comet Giacobini-Zinner in 1985, proving the “dirty-snowball” theory with its observations [16]. Then, five spacecraft from the USSR (Vega 1 and 2), Japan (Sagigake and Suisei), and Europe (Giotto) were launched to make a flyby with Halley’s comet in 1986. A more ambitious challenge was undertaken by space scientists in 1999 with the comet sample return mission known as Stardust [7]. Its spacecraft had a close encounter with comet Wild 2, collecting samples of comet dust in aerogel. More recently, NASA’s Deep Impact probe was launched to reach comet Temple 1 in 2005 and send a projectile to it, creating an impact crater and carrying out spectroscopy of the ejected materials [6].

A more spectacular approach to comet exploration is under completion, thanks to the European Space Agency’s probe Rosetta [2]. As one of ESA’s cornerstone missions, Rosetta is devoted to enhance our understanding of the formation and evolution of the solar system as well as the origin of life by investigating the 4 km-wide comet 67P/Churyumov-Gerasimenko. Unlike past missions, Rosetta is the first probe to carry out a close study of the nucleus, orbiting a spacecraft around the target comet. Even more challenging was its further goal of attempting the first ever landing on a comet surface, enabling the first ever in-situ analysis of cometary soil.

Right after arrival at the target comet in 2014, Rosetta started investigating the comet nucleus and the gas and dust ejected from it, by combining remote and direct sensing techniques. On November 12, 2014, its lander Philae (see Fig. 1) was commanded to self-eject from Rosetta and unfold its three legs, ready for a soft touchdown at the end of a ballistic descent [4].

Philae was headed to the landing site named Agilkia. The release and

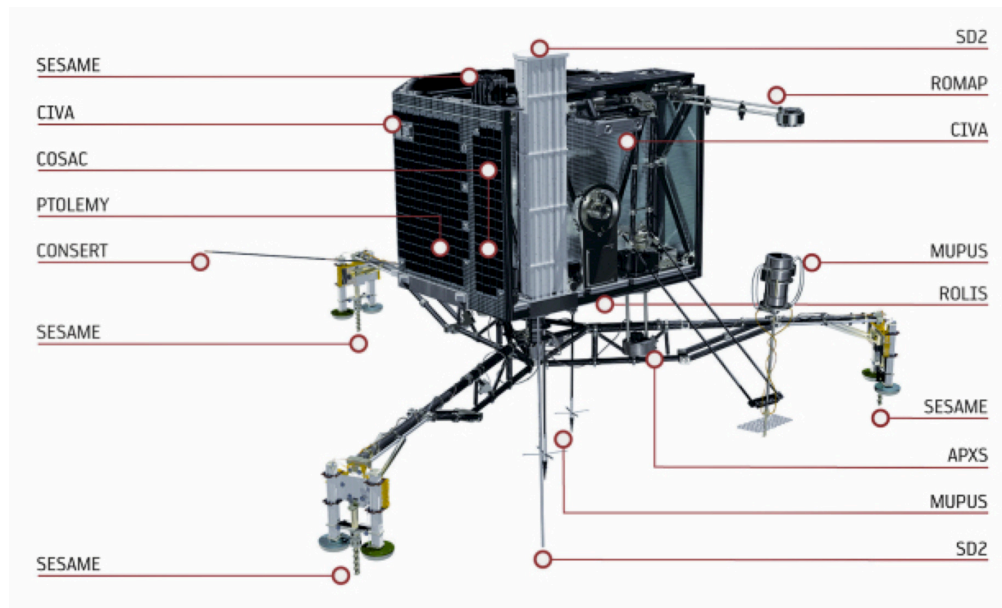

Figure 1: The lander Philae onboard Rosetta mission (Credits: ESA/ATG medialab).

descent were performed as planned, with some of the scientific instruments starting already their scientific activities to measure comet properties at decreasing distances from the nucleus. The lander touched down in Agilkia within about 100 m of its target. Immediately after touchdown, harpoons were commanded to fire in order to anchor the lander to the ground and prevent it escaping from the comet's extremely weak gravity. Contrary to the planning, some elements of Philae's landing system (the cold gas thruster and the anchors) were unable to operate and fix onto the surface at touch down. Consequently, two bounces occurred in a totally unexpected pattern and finally Philae came to rest on the comet, at a different and still not precisely known landing site later named Abydos.

Right after landing, Philae acted as an independent spacecraft, as it was

provided with all subsystems needed to survive and work alone on the comet. The orbiter was used only as a communication relay with the Earth. The ten scientific instruments onboard Philae started performing their surface measurements after touchdown. Among the specific instruments carried on Philae, the sampling, drilling and distribution (SD2) subsystem [10] had the important role of providing in-situ operations devoted to soil drilling, sample collection, and their distribution to the evolved gas analyzers COSAC (Cometary Sampling and Composition experiment [15]) and PTOLEMY [17], and to the camera system ÇIVA [3].

Due to the non-nominal landing, Philae's conditions were extremely critical: Philae was not anchored to the soil and was leaning on the comet surface shakily, with significant limitation on power availability. This strongly affected the decision on whether to operate SD2, as it could pose significant risks to subsequent Philae operations. Nevertheless, SD2 was operated on the comet on November 14, 2014 even if the actual operational conditions were far from the reference. The instrument performed a roto-translation movement to reach a distance of 468.5 mm from the lander baseplate and to deliver a sample to COSAC. In addition, a Carousel rotation was performed to support PTOLEMY sniffing activities.

This paper is devoted to provide an overview of SD2 on-comet operations and to summarize the results based on SD2 telemetry. In addition, the analysis of the images taken by the camera system ROLIS (Rosetta Lander Imaging System [13]) on the drilling area is presented to support the interpretation of SD2 telemetry.

The paper is organized as follows. The description of SD2 is reported in

Table 1: Environmental parameters for SD2 design.

Parameter	Range
Soil compressive strength	50 Pa – 50 MPa
Temperature	-140 °C – +50 °C
Pressure	10^{-5} mbar – 1 bar

Sect. 2. Section 3 summarizes the activities performed by SD2 during the cruise phase, prior to landing. The strategy adopted for SD2 on-comet operations is detailed in Sect. 4. Section 5 describes the on-comet activities, and the analysis of SD2 telemetry and ROLIS images. Finally, Sect. 6 concludes the paper.

2. Sampling, Drilling, and Distribution Subsystem

SD2 is devoted to support Philae’s activity by drilling into the cometary soil, collecting samples, and distributing them to the scientific instruments ÇIVA, PTOLEMY, and COSAC. The development of SD2 was committed to Politecnico di Milano and Selex-ES SpA by the Italian Space Agency. The instrument is mounted on Philae’s baseplate (see Fig. 1), and it is equipped with a drill able to collect several samples of 10-40 mm³ at different depths. The samples can be collected from different holes along a working circle by rotating the Lander platform around its z (vertical) axis [5].

SD2 was designed to operate in critical thermal-vacuum conditions and to meet demanding mass/power resources limits. The driving environmental parameters for the design were comet soil strength, temperature, and gas pressure at surface (see Table 1). Relatively wide ranges of the design parameters were inevitably used to account for the lack of accurate knowledge

of the comet environment. Consequently, the technological solutions adopted were selected to guarantee reliability in these extreme conditions [10]. Drill actuation makes use of solid and self lubrication, brushless motors, and low friction/antijamming approaches. The drill rod was designed to cope with a large range of materials and to minimize power consumption. Electronics manufacturing fulfils radiation resistance requirements and a structural shell made of carbon fibre was added to protect the mechanisms and minimize contamination. All the sensors selected feature brushless technology. In some cases, due to the lack of adequate space qualified sensors, commercial products were modified and tested to meet the extreme operational requirements.

SD2 has a total mass of 5100 g and is composed of

- a mechanical unit (3700 g);
- an electronic unit embedding SD2 software (1000 g);
- the harness for electrical connection between the mechanical and electronic units (400 g).

The SD2 mechanical unit consists of the *tool box*, the *drill*, and the *Carousel* (see Fig. 2). The tool box is the assembly housing containing all the mechanisms for drilling and sample acquisition in a protective structural shell made of carbon fibre. The shell avoids drill damage due to vibrations and shocks during launch and landing phases. The SD2 assembly includes the remaining two main parts: the drill itself and a carousel at the assembly base with ovens to be filled with soil samples.

The drill is made of austenitic stainless steel, which is not brittle at low temperature. Its diameter is 12 mm and it has a maximum extension of 498.5

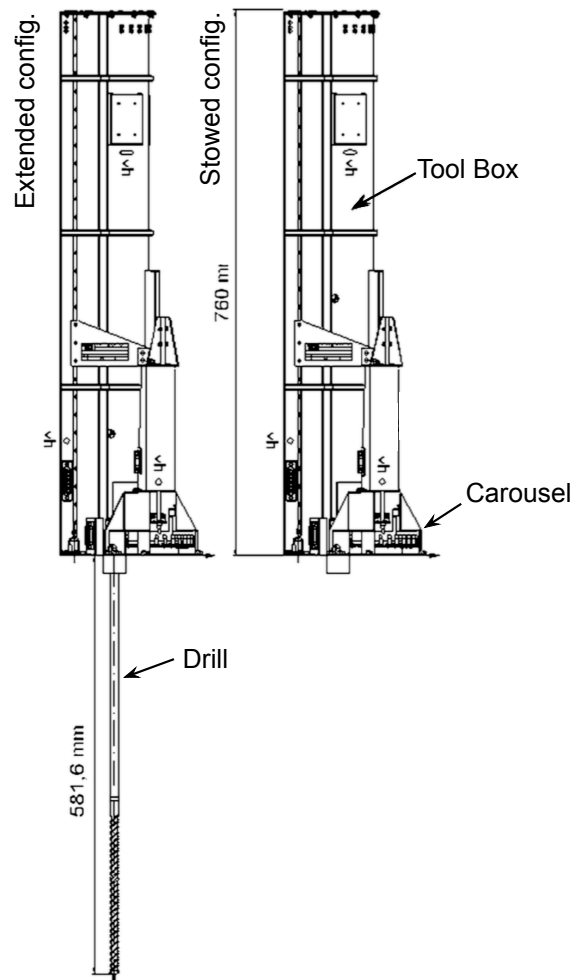

Figure 2: SD2 mechanical unit in stowed and extended configuration (Credits: Selex-ES.

mm from the lander baseplate. Polycrystalline diamonds have been used to reinforce the drill bit for hard soil drilling. The geometry of the bits have been optimized by theoretical analysis, numerical simulations, and experimental tests to maximize the cutting capability with low vertical thrust (100 N) and low power consumption. The power consumption during operations has a maximum average value of about 20 W. The sampling functionality is based



(a) Drilling configuration



(b) Sampling configuration

Figure 3: SD2 drill bit in drilling and sampling configuration.

on the use of a sampling tube, which is integrated in the drill rod to form a unique auger. After the drill reaches the desired depth, the sampling tube is protracted from the drill bit to pick up the sample from the soil (see Fig. 3). This solution was adopted to guarantee that the sample is collected simultaneously to achieving the desired depth, minimizing the risk of hole collapse during sampling.

A dedicated electromagnetic mechanism actuates the sampling tube by releasing a spring. In order to protect the mechanism from the action of friction and avoid locking, neither electrical slip rings nor mechanical parts in contact with relative rotation were used to release the spring. During drilling, a locking mechanism acts on the head of the sampling tube and moves jointly with it. When the sampling tube release is commanded, a current pulse of 50 ms feeds a coil that removes the locks and release the spring. Before starting a new drilling procedure, the drill bit and the locking mechanisms are rearmed mechanically by pushing the sampling tube inside

the drill rod using a dedicated rearming oven (see *drill bit rearming* in Sect. 2.1). After the drilling and sampling operations, the drill is moved back to its home position, ready to deliver the sample to the assigned oven.

The drill has two degrees of freedom: translation, to reach the comet surface, and rotation around its axis, to penetrate the soil. This solution allows operations with different combinations of the two movements, according to the different conditions that may occur on the comet. The stepper motors for the translation and rotation can be commanded in torque and speed independently [1]:

- the motor torque levels for translation and rotation can be commanded in the range 1-7, corresponding to ranges in the commanded current from 75 mA to 600 mA for the translation motor and from 250 mA to 2000 mA for the rotation motor;
- the translation and rotation speed levels can be commanded in the range 1-31, corresponding to the ranges 0.01-19.20 mm/min and 5-135 rpm, respectively.

The drill movements are monitored through the available telemetry, which includes the position of the drill bit with respect to its reference position (maximum admissible offset: 590 mm), the drill rotation speed and direction (clockwise or counterclockwise), SD2 power consumption, and flags for drilling failures.

The Carousel is a rotating platform hosting 26 small ovens (see Fig. 4). During drilling, the Carousel is set to its home position, where an indentation on the outer perimeter of the platform allows the drill rod to pass through the

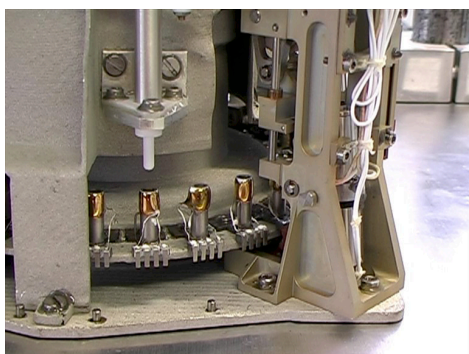

(a) High-temperature ovens

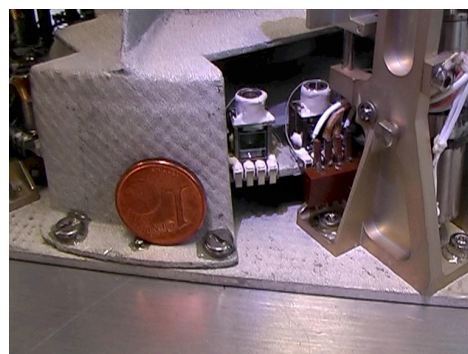

(b) Medium-temperature ovens

Figure 4: SD2 Carousel and ovens.

Carousel plane. Once the drill is back to its home position with the sample, the Carousel is rotated to put the assigned oven under the drill bit. The drill translates downward towards the oven, pushing the sampling tube against the oven side. Consequently, the sampling tube retracts and the sample is delivered into the oven. The Carousel is then rotated to deliver the sample to the scientific ports of ÇIVA, PTOLEMY, or COSAC. The ovens provide the interface between the collected sample and the scientific instrument. Before the analyses, the tapping station of the scientific port is closed to seal the oven and the sample undergoes a heating process. The emitted gas is then conveyed to the instrument. Depending on the scientists requests, two kinds of ovens can be used (see Fig. 4):

- 16 high temperature ovens (HTO, see Fig. 4(a)) suited for high temperature experiments (up to $+800^{\circ}\text{C}$);
- 10 medium temperature ovens (MTO, see Fig. 4(b)) with an optical sapphire prism, suited for the analysis by visible I/R microscopes and

for medium temperature experiment (up to +180°C).

Specific technological processes have been used for the manufacturing of the MTOs: sapphire prism brazing to the platinum oven base, platinum oven brazing to the titanium support, ceramic insulation of the wound platinum wire and cryogenic adhesive, tested at -195°C, to lock structural screws.

The stepper motor for Carousel rotation can be commanded in torque and speed independently. The telemetry to monitor Carousel movement includes the Carousel angular position, SD2 power consumption, and flags for Carousel rotation failures.

SD2 electronic unit is installed into the warm compartment of the Lander and incorporates all electronics to control the mechanical unit. The hardware and software installed provide the interface between the mechanical unit and the Lander control system, the Command and Data and Management Subsystem (CDMS). SD2 is supplied by Philae’s power subsystem with a 28 V line from the Lander primary bus, devoted to the mechanical unit, and some auxiliary power lines (± 5 V, ± 12 V) from the Lander secondary converters.

2.1. Typical Sampling Procedure

Table 2 reports the steps of a typical SD2 sampling procedure [9]. The steps can be grouped in elementary blocks:

- *Drill bit rearming* (Steps 1 to 4). SD2 drill bit has flown in unarmed configuration (i.e., with the sampling tube extracted) throughout Rosetta’s cruise phase. Consequently, the first operation to be accomplished is the drill bit rearming. A special oven is available to this purpose: the rearming (or dummy) oven, whose edge thickness

Table 2: Steps of a typical SD2 sampling procedure.

Step	Description
1	Carousel rotation to put the rearming oven under the drill
2	Downward drill translation for bit rearming
3	Upward drill translation to home position
4	Carousel rotation to home position
5	Drilling to desired offset from SD2 reference position
6	Upward drill translation of 1 mm
7	Sampling tube release
8	Drill rotation for 20 s
9	Upward drill translation to home position
10	Carousel rotation to put the desired oven under the drill
11	Downward drill translation for sample release
12	Upward drill translation to home position
13	Carousel rotation to put the oven under the desired scientific port

matches exactly the one of the sampling tube. The Carousel is first rotated to put the rearming oven under the unarmed drill bit (step 1). Then, a 15 mm downward Drill translation is performed at about 2 mm/min to push the sampling tube against the edge of the rearming oven (step 2). **Consequently, the sampling tube retracts into the drill rod by compressing the release spring until the locks of the electromag-**

netic mechanism are rearmed to secure the sampling tube. Once the bit is rearmed, the drill and the Carousel are moved back to their home positions (step 3 and 4, respectively).

- *Drilling* (Step 5 to 6). SD2 can now start the drilling activity. This is performed by commanding a drill roto-translation movement to a specified offset from a reference position. The drill rotation and translation are commanded separately, with given torque and speed levels. Once the bit reaches the desired offset, the drill translates upward for 1 mm (step 6) to prepare for sampling.
- *Sample retrieval* (Steps 7 to 9). The sampling activity can now start. The sampling tube is released (step 7) and pushed against the bottom of the hole, preventing the chips uplifted at the sampling spot from falling back. Then, the drill rotates (step 8) to let the sampling tube act as a coring device, pressed by its own internal pushing spring. At the end of the coring action, the drill rod translates back to its home position (step 9).
- *Carousel rotation: desired oven under drill* (Step 10). The drill bit is now at its home position, with the sampling tube in extracted configuration and containing the soil sample. The sample must be released in the oven designated to its analysis. To this aim, a Carousel rotation is performed to put the desired oven under the drill bit.
- *Sample release* (Steps 11 to 12). After completion of the previous step, the sample can be released into the desired oven. As schematically illustrated in Fig. 5, this operation is performed by a 1 cm downward

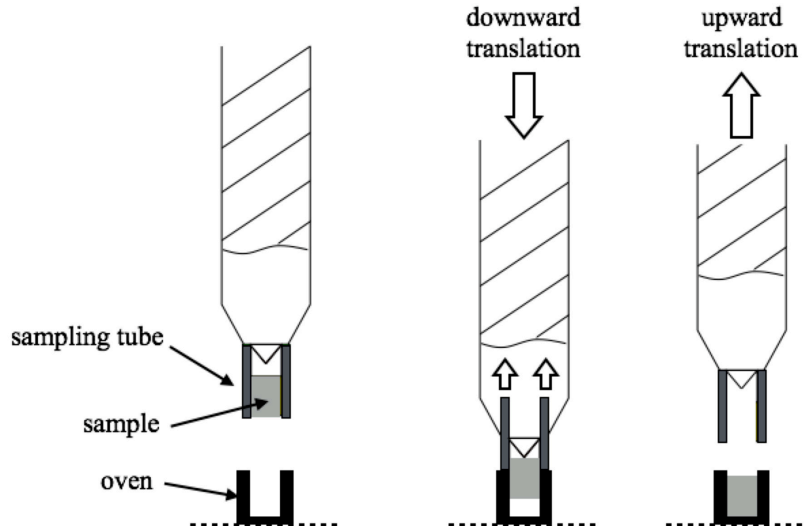

Figure 5: Schematic representation of the sample release operation.

drill translation (step 11) to push the sampling tube against the oven edge and exploit the piston effect of the central part of the drill bit during the pushing action. Once the sample has been released, the drill can translate back to its home position (step 12).

- *Carousel rotation: desired oven under scientific port* (Step 13). Finally, the Carousel is moved to put the oven with its sample under the designated scientific port for ÇIVA, PTOLEMY, or COSAC analyses.

3. Cruise Activities

Following Rosetta's launch in 2004 and after instrument commissioning, SD2 status was regularly monitored through the *payload checkouts* (PC), which are regular health checks of Philae's system, subsystems and instruments carried out during the cruise phase. Politecnico di Milano was respon-

sible for the development, verification, and delivery of the commands to be loaded onboard Philae and automatically executed by the onboard computer during all PCs.

A total of 13 PCs were performed during cruise between commissioning and deep space hibernation. During each PC, the instruments had the opportunity to activate their units, exercise mechanisms, refresh EEPROM memories, and perform calibrations and software updates. Interactive operations were only possible during the active PCs, whereas passive PCs allowed for standard procedures for general monitoring of the instruments and lander status.

A list of the SD2 activities during all PCs is reported in Table 3. Only SD2 translation and rotation resolvers are activated during passive PCs. This allows the SD2 team to check the instrument status and to measure the drill and carousel positions that are compared with expected values. Active payload checkouts were devoted to exercise the drill and the carousel. More specifically:

- downward and upward drill translations were executed to verify the drill translation motor status;
- clockwise and counterclockwise drill rotations were executed to check the drill rotation motor status;
- Carousel movements were performed for stand-alone and combined tests with ÇIVA, Ptolemy, and COSAC;
- the EEPROM memory was refreshed before hibernation.

Table 3: SD2 activities during payload checkouts.

PC#	Type	Activities
PC0÷3, PC5, PC9	passive	Standard checkout
PC7, PC11	-	Cancelled
PC4	active	7 carousel rotations for combined tests with COSAC and ÇIVA
PC6	active	<ul style="list-style-type: none"> • 7 carousel rotations for combined tests with COSAC and ÇIVA • 1 CW and 1 CCW drill rotation (21 s)
PC8	active	<ul style="list-style-type: none"> • 6 carousel rotations for combined tests with ÇIVA • 1 CW and 1 CCW drill rotation (21 s) • 1 DW (to 0.3 mm) and 1 UW (to 0 mm) drill translation • EEPROM refresh
PC10	active	<ul style="list-style-type: none"> • 8 carousel rotations for combined tests with COSAC and ÇIVA • 1 CW and 1 CCW drill rotation (90 s) • 1 DW (to 2.5 mm) and 1 UW (to 0 mm) drill translation
PC12	active	<ul style="list-style-type: none"> • 2 carousel rotations for combined tests with COSAC • EEPROM refresh
PC13	active	Standard checkout

As a safety measure for Rosetta's orbiter, the activation of the 28 V line to SD2 from the Lander primary bus was commanded only during SD2 mechanical operations. The downloaded telemetry shows that SD2 behaved nominally during all PCs. The amount of collected data was consistent with the performed activities, and the telemetry for both the Carousel and the drill movements matched expectations within the admissible tolerances.

In addition to regular PCs and following Rosetta's deep-space hibernation phase, all Philae's payloads were put through a post-hibernation commissioning phase in April 2014. First of all, the elementary movements performed during PCs were repeated by commanding minimum torque levels in order to check SD2 in-flight behaviour with minimum currents. In addition, two roto-translation movements were performed for the first time, with the same settings used during on-comet operations. The main goals of these movements were:

- to verify SD2 in-flight behaviour during the combined use of both drill motors;
- to measure SD2 in-flight power consumption during a typical drilling activity;
- to identify possible interferences with other instruments during drilling operations.

Once again, the resulting telemetry turned out to be nominal. Based on these results, SD2 was considered fully commissioned and ready for the on-comet phase.

Table 4: SD2 activities planned for the FSS phase.

Hole#	SD2 offset [mm]	Oven type	Oven # (SD2 count)	Instrument
1	530	HTO	19	PTOLEMY
1	560	HTO	17	COSAC
2	590	MTO	3	ÇIVA & COSAC

4. On-comet Operation Planning

All cruise activities, as well as the execution of SD2 sampling procedures (see Table 2), require the development of dedicated operational procedures. Each procedure is performed by executing a dedicated list of commands, which are referred to as *mission plans* (MPs).

Prior to Philae’s landing in November 2014, an intense planning activity was carried out to prepare SD2 for the on-comet operations. Right after landing, Philae’s instruments performed a first scientific sequence (FSS) of activities lasting about 5 comet days in total. The lander was powered to a large extent by its primary battery (capacity: 1 kWh) and several instruments and subsystems were operated simultaneously. SD2 acted as a lander subsystem by supporting COSAC and PTOLEMY activities. After collecting and prioritizing ÇIVA, PTOLEMY, and COSAC requests (i.e., number of samples, depths, ovens and scientific ports to be used), a list of three sampling procedures was prepared for the entire FSS (see Table 4). The first sampling procedure was devoted to catch a sample from an SD2 offset of 530 mm, to discharge the sample into an HTO, and to serve PTOLEMY with

the captured sample. The second procedure was aimed at taking a sample deeper in the same hole and discharging the sample into a different HTO to be analysed by COSAC. Lastly, the third sample was to be captured from a different hole and from the maximum offset (590 mm); the sample was to be discharged in a medium-temperature oven for ÇIVA inspection and COSAC subsequent analysis.

A long term science (LTS) phase was planned after FSS, relying on the power from the solar generator and a secondary battery. The goal of SD2 operation during LTS was twofold:

- to keep supporting ÇIVA, PTOLEMY, and COSAC activities;
- to act as a scientific instrument.

Indeed, recent studies had proven the existence of a correlation between SD2 behavior during drilling and the mechanical characteristics of the cometary soil [11, 1]. A dedicated strategy was developed, which was based on performing multiple drilling activities with varying speed levels to identify the drill working zones for different commanded torques. Information about the mechanical characteristics and inhomogeneity of the cometary soil was to be obtained by comparing the working zone measured on the comet during the LTS phase and those from a database of specimens available on the ground. Being based on multiple perforations, this strategy was time and power consuming, and required specific MPs to be developed for each drilling procedure.

Preparing SD2 for FSS and LTS activities was not a trivial task. Dedicated MPs were developed to fulfil the requests while

- minimizing the risk of failure on the basis of the limited knowledge of the comet environment;
- minimizing power and energy consumption;
- maximizing data return.

This required a strong interaction between the SD2 team and the other scientific instruments onboard Philae, under the coordination of the Science Operation and Navigation Center (SONC) and the Lander Control Center (LCC), to perform accurate operation planning.

4.1. Elementary Mission Plans and Memory Allocation

The short duration of the FSS and the significant communication delays during both FSS and LTS made operation planning even more challenging by limiting the possibility of uploading new commands from the ground. All activities had to be executed automatically, minimizing ground support. Consequently, the SD2 team was asked to meet the additional operational requirement of optimizing the MP definition in terms of memory allocation, so as to guarantee the best use of the dedicated telecommand (TC) buffer and minimize the set of commands to be uploaded from the ground during both FSS and LTS. To this aim, the entire typical sampling procedure reported in Table 2 was divided into elementary MPs.

It is worth observing that some of the elementary blocks defined in Sect. 2.1 from the steps of Table 2 can be repeated identically in all sampling procedures. This is the case for drill bit rearming, sample retrieval, and sample release. For all these activities, the same sequence of commands can

be executed in all sampling procedures, without the need of adapting SD2 settings to the specific procedure. Consequently, one MP can be developed for each of the above elementary blocks. These MPs, referred to as *common MPs*, can be loaded onboard Philae and used at any occurrence during all sampling procedures.

On the other hand, specific mission plans must be prepared for the remaining activities:

- *Drilling*. This step involves the roto-translation movement to drill into the cometary soil to the desired offset and the 1-mm upward translation in preparation for sampling. The commands to be executed depend on the offset to be reached, which can vary among the different sampling procedures;
- *Carousel rotation: desired oven to drill*. This step is devoted to rotate the Carousel and put the assigned oven under the drill bit for sample release. The commands depend on the specific oven to be used, which is different for each sampling procedure;
- *Carousel rotation: desired oven to port*. This step is devoted to rotate the Carousel, and put the assigned oven and its sample under the ÇIVA, PTOLEMY, or COSAC scientific ports. Similarly to the previous step, the associated commands depend on the specific oven and scientific port to be used, which might vary among the different sampling procedures.

Since the commands associated to the above steps must be adapted to each sampling procedure, *specific MPs* must be designed and uploaded for each sampling procedure.

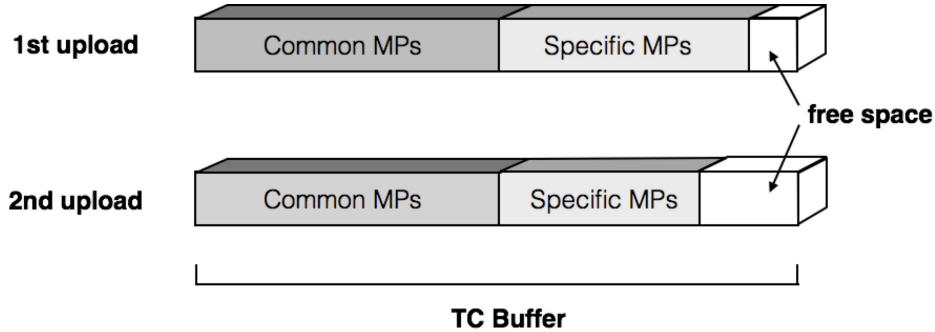

Figure 6: TC buffer allocation strategy.

The above distinction between common and specific MPs was reproduced on the SD2 TC buffer to optimize memory allocation and management. More specifically, the TC buffer was divided in two segments (see Fig. 6): the first segment was devoted to store the common MPs, whereas the remaining part contained the MPs specific to each sampling procedure. Evidently, common MPs are ideally stored only once in the TC buffer and executed identically by the onboard computer during all sampling procedures. Only the specific MPs must be developed, uploaded and stored repeatedly onboard to serve the purpose of each sampling procedure. This reduced onboard memory utilization, maximized the number of commands stored in the SD2 TC buffer and limited the need of uploading commands from the ground.

SD2 commands are stored in the dedicated TC buffer in terms of sequences of 16-bit words. Each command requires a specific number of words to be stored, which can vary between a minimum of 2 words (e.g., to switch on/off drill and Carousel resolvers) and a maximum of 10 words (to load the data relevant to check possible obstructions of drill translation movements

by the landing gear). Consequently, the number of words and the portion of the TC buffer occupied by each MP depends on the specific sequence of commands needed for its implementation. Table 5 shows the number of words required by the elementary blocks defined in Sect. 2.1. As can be seen from the table, the portion of the TC buffer allocated to the common MPs included 188 words. Overall, the implementation of the three FSS sampling procedures in Table 4 required 507 words.

4.2. Contingency Plans

Besides affecting MPs definition and TC buffer allocation, the short duration of the FSS, the communication delays, and the limited frequency with which communication links could be established prevented SD2 from being operated interactively. However, SD2 was provided with limited autonomy in terms of operational capabilities: the automatic recovery actions implemented in SD2 software were mainly devoted to abort command execution in case SD2 entered a dead status, or to increase the applied torque during drill translation in case of drill translation speed check failure. Consequently, the SD2 team and the LCC were asked to take on the new challenge of increasing SD2 autonomy to deal with emergencies. The aim was twofold:

- To try to recover the subsystem and resume operations to complete the sampling procedure;
- To minimize the risk of impeding subsequent Philae operations by putting SD2 in a safe configuration before aborting the sampling procedure completely.

Table 5: Number of words allocated on the SD2 TC buffer to store the elementary blocks of SD2 activities (*depending on the instrument to be served).

Elementary block	Steps	# of words
Drill bit rearming	<ul style="list-style-type: none"> • Carousel rotation to put the rearming oven under the drill • Downward drill translation for bit rearming • Upward drill translation to home position • Carousel rotation to home position 	98
Drilling	<ul style="list-style-type: none"> • Drilling to desired offset from SD2 reference position • Upward drill translation of 1 mm 	55
Sample retrieval	<ul style="list-style-type: none"> • Sampling tube release • Drill rotation for 20 s • Upward drill translation to home position 	42
Carousel rotation: desired oven to drill	<ul style="list-style-type: none"> • Carousel rotation to put the desired oven under the drill 	25
Sample release	<ul style="list-style-type: none"> • Downward drill translation for sample release • Upward drill translation to home position 	48
Carousel rotation: desired oven to port	<ul style="list-style-type: none"> • Carousel rotation to put the oven under the desired scientific port 	25 – 27*

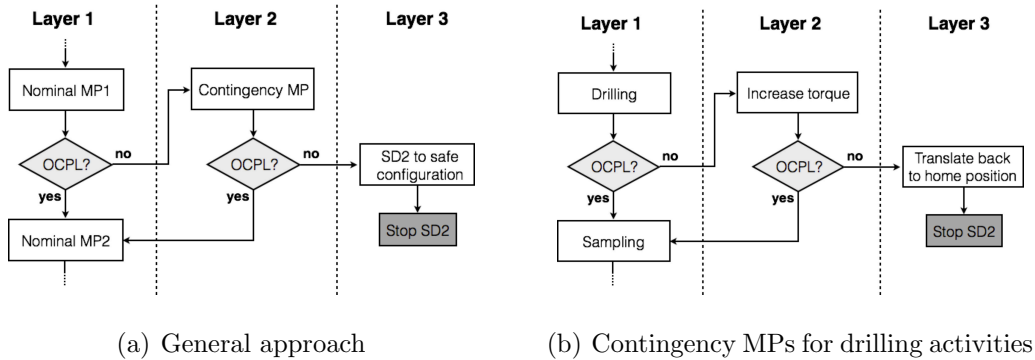

Figure 7: Management of SD2 emergencies by CDMS.

Contingency plans were then developed to increase robustness to uncertainties and minimize the need of uploading recovery procedures from the ground.

The strategy was based on three operational layers, managed by Philae’s CDMS. As illustrated in Fig. 7(a), CDMS starts executing the nominal MP contained in the first operational layer. At the end of command processing, SD2 software confirms that the associated operation has been successfully completed by sending the operation completed (OCPL) request code to CDMS. If the OCPL message is not received by the CDMS within an assigned timeout, SD2 is declared to be in emergency status and CDMS switches to the second operational layer, where a contingency MP is executed. Similarly, CDMS waits for the OCPL message associated to the contingency MP. Once again, if the OCPL message is not received within an assigned timeout, the CDMS switches to the last operational layer, where SD2 is moved to reach a safe configuration and the entire sampling operation is aborted. This strategy is automatically handled onboard Philae by the CDMS, without intervention from the ground.

Figure 7(b) shows an example of the three-layer strategy developed for

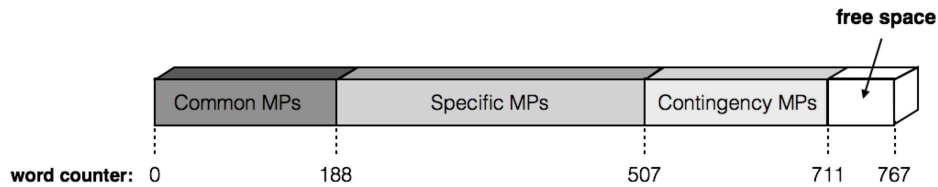

Figure 8: SD2 TC buffer allocation for the FSS phase.

the drilling phase of any sampling procedure. In case of failure of the nominal MP, the CDMS executes the contingency MP, where drilling is repeated by increasing the applied torque on both the translation and rotation motors. If the failure persists, the CDMS moves to the third layer: the drill translates back to its home position and the entire sampling procedure is aborted. In so doing, the risk of impeding subsequent Philae operations is minimized.

All the emergency procedures adopted during the FSS phase required 204 words to be allocated in the SD2 TC buffer. In its standard use, the buffer can contain 512 words. They would not be sufficient to store entirely the 711 words necessary to execute all of the FSS sampling activities of Table 4 and the contingency MPs. Exceptionally, SD2 was granted an extension of the dedicated TC buffer for the FSS phase to a maximum of 767 words. This allowed the SD2 team to store the sequence of nominal and contingency MPs for the entire FSS in the TC buffer, removing the need of command uploads during FSS activities. The final allocation of the SD2 TC buffer during FSS is sketched in Fig. 8.

5. On-comet Activities

Right after Philae’s landing on November 12, 2014, despite the non-nominal landing conditions, Philae’s primary battery allowed the instruments

to operate for 63 hours during FSS. However, the sequence of operations had to be reshuffled and adapted to the unexpected scenario. The operations of instruments requiring mechanical movements like SD2 were postponed and eventually executed in the latest FSS activity blocks.

As far as SD2 is concerned, the unexpected events during landing caused major consequences:

- The lander was not anchored onto the surface; consequently, no reaction was available to the force that SD2 would have exerted during drilling, affecting the possibility of penetrating the soil;
- Even in case of a successful penetration, Philae's possible movements during drilling could have favoured jamming conditions.

Nevertheless, SD2 was operated on 67P/Churyumov-Gerasimenko on November 14, 2014.

5.1. Telemetry Analysis

SD2 was commanded to execute the second sampling procedure from Table 4, i.e. to reach an offset of 560 mm (corresponding to a distance of 468.5 mm from the lander baseplate), perform the sampling sequence, release the sample into the HTO #17, and serve the sample to COSAC for analysis. In addition, the Carousel was eventually rotated back to its home position to allow PTOLEMY to perform a sniffing activity on a dedicated oven.

Following onboard execution, the generated telemetry was downloaded and analyzed through dedicated software, which allows the SD2 team to:

- verify SD2 status;

- check the drill and carousel positions during the execution of all operations;
- confirm the achievement of the operation objectives and the fulfillment of the constraints;
- analyze errors in case of non-nominal behaviors.

The telemetry produced shows that SD2 performed nominally. All mechanical operations and kinematic trajectories were executed correctly: the commanded drill and Carousel positions were reached within the admissible tolerances and the movements were performed with the commanded speeds. In addition, SD2 power and energy consumption matched expectations.

The first procedure to be executed was the drill bit rearming. More specifically,

- The Carousel was rotated to the position 1440 arcmin to put the rearming oven under the drill bit;
- A downward drill translation to reach an offset of 15 mm with a commanded speed of 2 mm/min was executed, followed by the translation back to home position with the same speed;
- The Carousel was then rotated back to its home position (0 arcmin) to prepare SD2 for drilling.

As expected, a total of 163 scientific packets were downloaded and analyzed. Table 6 summarizes SD2 performance during drill bit rearming by comparing the reached positions with the commanded ones.

Table 6: SD2 performances during drill bit rearming in terms of reached positions.

Activity	Target position	Reached position
Rearming oven under drill bit	1440 arcmin	1441 arcmin
Downward drill translation to 15 mm	15.00 mm	15.08 mm
Upward drill translation to 0 mm	0.00 mm	-0.04 mm
Carousel to home position	0 arcmin	10 arcmin

The drilling and sampling operations followed. The drill executed the roto-translation to reach an offset of 560 mm. Then, after an upward translation of 1 mm, the sampling tube was extracted and the drill rotated to perform the coring action. Finally, the drill translated back to its home position. The drill position profiles during the roto-translation to 560 mm and the subsequent translation back to 0 mm is illustrated in Fig. 9. As can be seen, the drill bit reached the target offsets. The different slopes and durations of the two movements in the figure are associated with the different commanded speeds: a speed of about 7 mm/min was commanded for the roto-translation to 560 mm, whereas a speed of about 13 mm/min was used for the translation back to home position.

Table 7 shows the accuracy achieved at the end of the drill roto-translation and translation movements. In addition, Fig. 10 shows SD2 power consumption profiles during the same phases. The average SD2 power consumption during drilling was about 9 W, for an overall energy consumption of about 11 Wh.

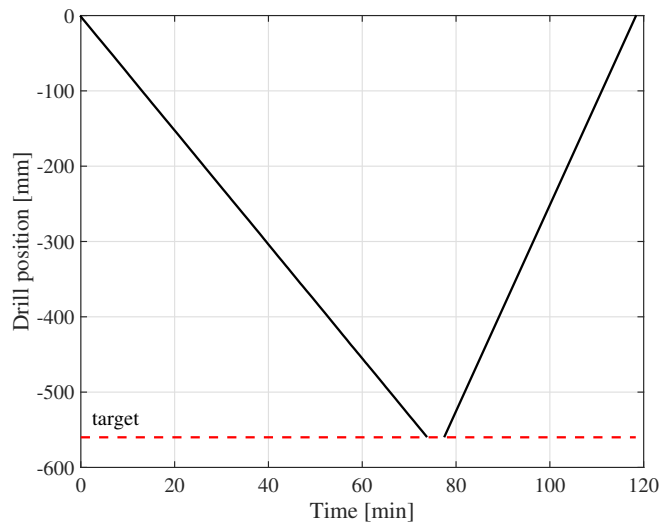

Figure 9: Drill position profiles during the roto-translation to 560 mm and the translation back to 0 mm.

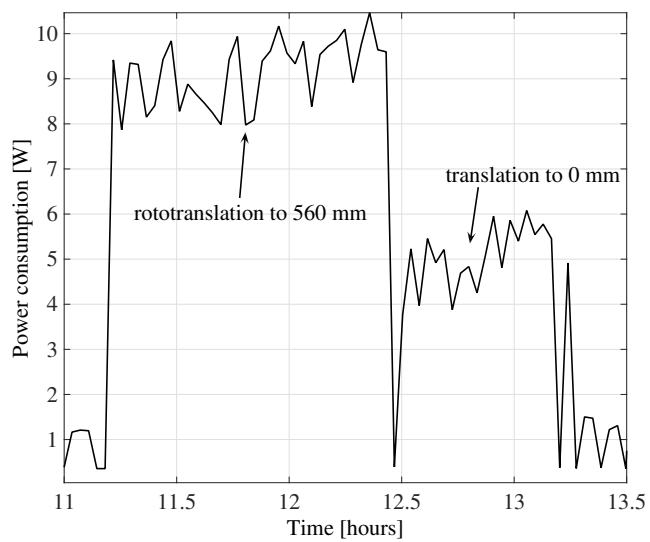

Figure 10: SD2 power consumption during the roto-translation to 560 mm and the translation back to 0 mm.

Table 7: SD2 performance during drilling and subsequent translation to home position.

Activity	Target position	Reached position
Downward drill roto-translation to 560 mm	560.00 mm	560.27 mm
Upward drill translation to 559 mm	559.00 mm	558.88 mm
Upward drill translation to 0 mm	0.00 mm	-0.07 mm

The Carousel was then rotated to reach an angle of 8640 arcmin, which corresponds to having the HTO #17 under the drill bit. Then, the sample release operations started: a 10 mm downward drill translation was commanded, followed by the translation back to home position. Finally, a Carousel rotation was executed to reach the angular position 15120 arcmin and put HTO #17 under the COSAC scientific port. Table 8 shows the accuracy achieved during these operations.

Table 8: SD2 performance during sample release in HTO #17 and its delivery to the COSAC scientific port.

Activity	Target position	Reached position
HTO #17 under drill bit	8640 arcmin	8638 arcmin
Downward drill translation to 10 mm	10.00 mm	10.05 mm
Upward drill translation to 0 mm	0.00 mm	-0.02 mm
HTO #17 under COSAC	15120 arcmin	15120 arcmin

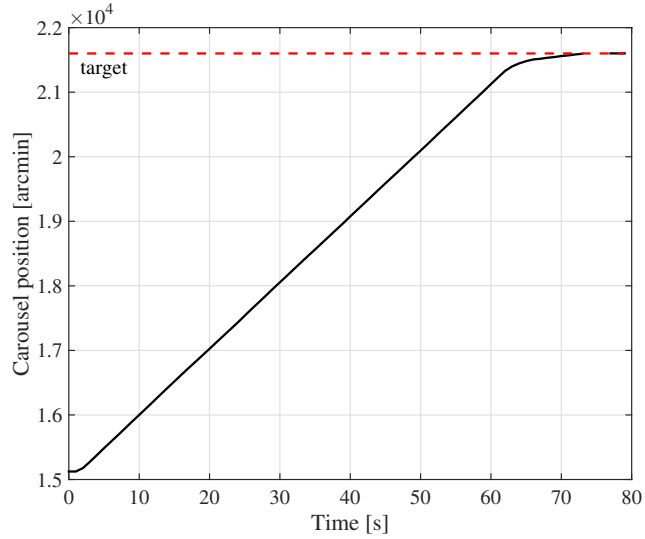

Figure 11: Carousel position profile during the Carousel rotation back to home position for PTOLEMY sniffing activities.

At the end of the sampling procedure, a Carousel rotation was commanded to reach the home position and allow PTOLEMY to perform the sniffing activity. The Carousel angular position profile during the rotation is illustrated in Fig. 11. The rotation starts from 15120 arcmin and, after about 80 s, the Carousel reaches the commanded home position (i.e. 0 arcmin or, equivalently, 21600 arcmin) with an error of 1 arcmin (see Table 9).

Table 9: SD2 performance during the Carousel rotation back to home position for PTOLEMY sniffing activities.

Activity	Target position	Reached position
Carousel to home position	0 arcmin	1 arcmin

The nominal behavior of SD2 during on-comet operations was a remarkable success: after more than ten years in space, the system has proven to satisfy the design requirements and to withstand the challenging operating conditions. Nevertheless, COSAC analysis of HTO #17 at the end of the sampling procedure shows that no volatiles and, probably, no soil sample were contained in the oven [12]. This suggests that sampling itself was not successful. Unfortunately, the telemetry of SD2 is not sufficient to rigorously confirm sample collection. More specifically, SD2 is not provided with sensors able to detect drill-soil interaction, and to confirm that the sample was actually collected in the sampling tube and released into the oven.

Other instruments onboard Philae can help to cast light on the issue. More specifically, thanks to a lander rotation performed at the end of the FSS, the camera system ROLIS could be used to reconstruct a three-dimensional model of the comet surface under the lander and to estimate the distance of the soil from the lander baseplate in the drilling area.

5.2. ROLIS Images Analysis

ROLIS is a CCD imaging system on the Philae lander designed to acquire images of the comet surface during descent and after landing [13]. The instrument is accommodated on the Philae instrument deck, on the so-called Common Working Circle (see Fig. 12), with its viewing direction oriented nadir. The field of view (FOV) covered by the ROLIS CCD is $55.6^\circ \times 55.6^\circ$ and its optical axis is parallel to the drill axis, with an offset of about 26 cm. As a consequence, the location of the putative SD2 borehole would be located at one edge of the ROLIS FOV, with its exact position being determined by the altitude of the instrument deck on the ground.

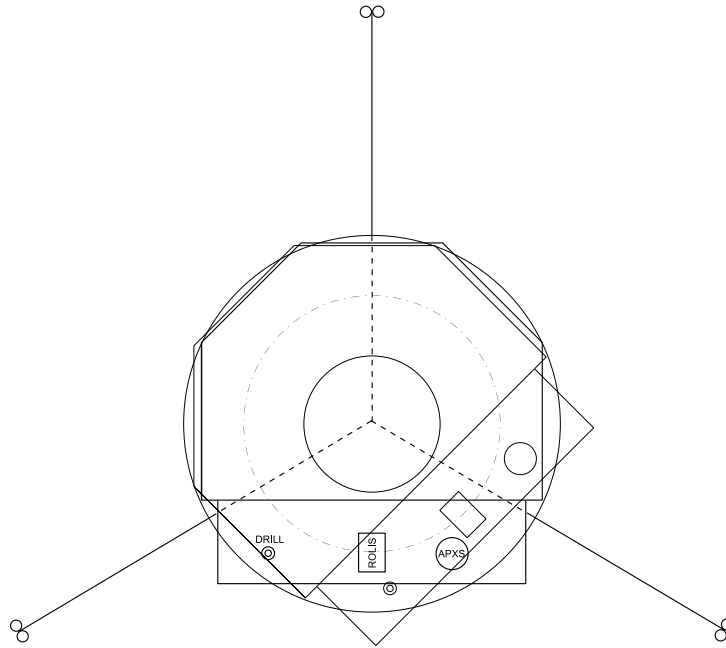

Figure 12: ROLIS, drill, and APXS accommodation on the Philae instrument deck.

At the beginning of the FSS, a set of ROLIS close-up images were taken “under” the lander. Two days later, by the end of the FSS, after the deployment of the two Philae instruments MUPUS (Multi-Purpose Sensors for Surface and Subsurface Science) and APXS (Alpha X-ray Spectrometer), and after the SD2 drilling attempt, using Philae’s ability to move its body (“the bubble”) with respect to its legs, clockwise bubble rotation and vertical translation commands were issued to the lander. The aim was to maximize power generation before the end of the FSS and to optimize the solar array illumination in preparation for a possible future LTS phase once the comet got closer to the Sun. After those bubble movements, a new set of ROLIS close-up images were acquired and transmitted to SONC.

Thanks to the vantage point difference between the two ROLIS image

sets it was possible to reconstruct, by stereo-photogrammetry, a 3D model of the soil area that is visible in both sets of images and to compute the distances between the soil features and the ROLIS lens' front principal point [14]. Figure 13 presents one of the ROLIS close-up images acquired after the bubble movements, overlaid with a color map indicating that distance.

Due to the SD2 and ROLIS instruments positioning on the lander and since the drill trajectory is parallel to the optical axis of the ROLIS camera, the drill can never get inside the ROLIS FOV. Nevertheless, using (i) the known movement of the drill tip relative to the first ROLIS close-up image frame, (ii) the vantage point difference between the two ROLIS close-up images and (iii) the ROLIS camera intrinsic parameters, the successive 3D positions of the drill tip during the drilling could be computed in the frame of the second ROLIS close-up image and then projected in 2D on that very image.

The resulting drill trajectory, depicted in red in the left of Fig. 13, shows that the drilling was actually performed in the void, in an area where the soil could not be reached by the drill. From the 3D reconstruction of the drilling scene (see Fig. 14), the soil was determined to be about 450mm too far to be reached by SD2. This information could however only be known a posteriori, after the drilling activity was performed, since the drill trajectory and thence the soil area to be drilled were not in the field of view of the ROLIS camera before the bubble rotation.

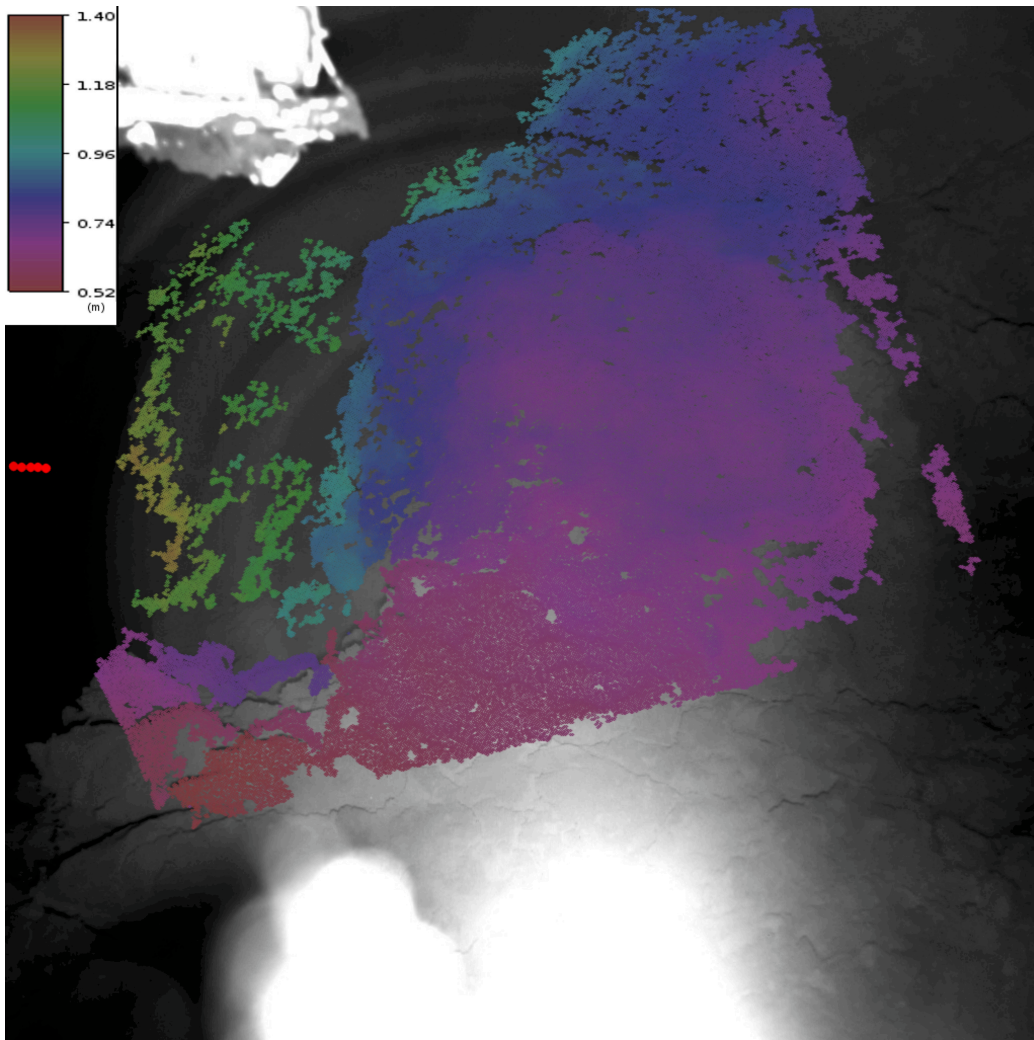

Figure 13: Drilling trajectory (red dots) and depth map.

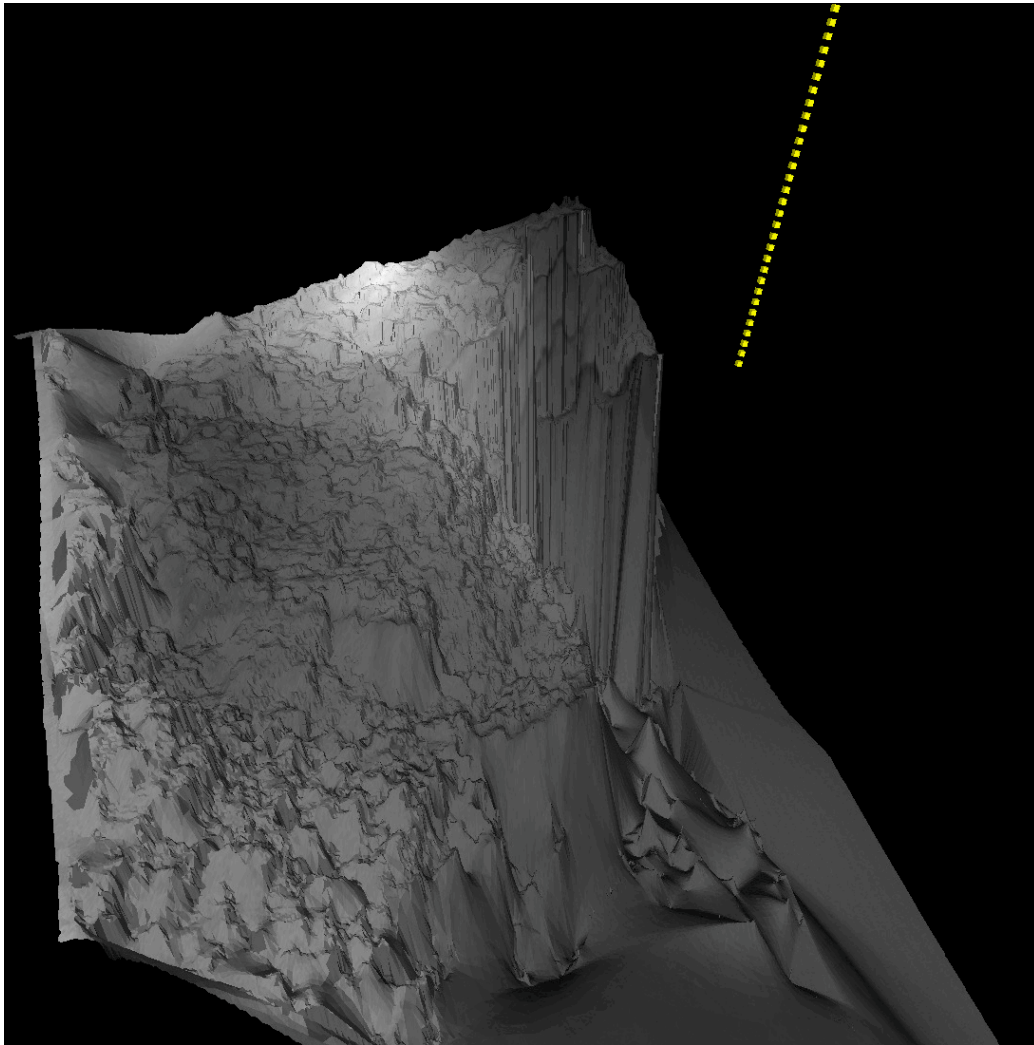

Figure 14: Drilling trajectory (yellow dots) and 3D local model of the comet surface.

6. Conclusion

This paper presented the results of the analysis of SD2 on-comet operations onboard the lander Philae of the Rosetta mission. More specifically, the strategy adopted for SD2 operation to face the operational criticalities was described. Then, the analysis of the SD2 telemetry from the first sequence of on-comet activities was illustrated and the results of ROLIS image processing were presented to support data interpretation.

The telemetry produced by SD2 shows that the instrument performed nominally and that all mechanical operations and kinematic trajectories were executed correctly, with the expected power consumption. This is a great engineering achievement for the drilling and sampling system, which was operated on a comet after more than ten years in space. Unfortunately, the landing was not nominal and Philae was not anchored to the comet soil, which affected SD2 performance. In addition, the analysis of ROLIS images suggests that the distance of the soil from the lander baseplate in the drilling area may have been larger than the maximum offset that can be reached by the drill. This would have precluded the possibility of collecting a soil sample in the first sequence of scientific activities. This conclusion matches the results of COSAC analysis on the oven used for the sampling procedure.

At the time of this writing, the analysis of PTOLEMY sniffing activities during FSS is ongoing. In addition, after about six months from landing, Philae woke up from its hibernation period after FSS. An intense activity is ongoing to decipher the status of Philae and to prepare both the orbiter and the lander for the subsequent LTS phase.

7. Acknowledgements

The activity presented in this paper was funded by the Italian Space Agency (ASI, Contract n. I/024/12/0). The authors are grateful to Enrico Flamini and Raffaele Mugnuolo from ASI, and to Piergiovanni Magnani and Edoardo Re from Selex-ES for their constant support throughout the mission. The authors would like to thank Thierry Germa (Magellium) for the distances map and the digital terrain model computation, and the ROLIS team (DLR) for their help on scaling the distances. In addition, the authors would like to express their gratitude to LCC and SONC for their essential contribution to SD2 operations.

References

- [1] R. Armellin, P. Di Lizia, M. Crepaldi, F. Bernelli-Zazzera, A. Ercoli Finzi, Scientific use of the Sampler, Drill and Distribution Subsystem (SD2), *Journal of the British Interplanetary Society*, 67 (2014) 426–433.
- [2] C. Berner, L. Bourillet, J. Ellwood, M. Kasper, P. Kletzine, R. Schultz, G. Schwehm, Rosetta: ESA’s Comet Chaser, *ESA Bulletin*, 112 (2002) 10–37.
- [3] J.P. Bibring, P. Lamy, Y. Langevin, A. Soufflot, M. Berth, J. Borg, F. Poulet, S. Mottola, CIVA, *Space Science Reviews*, 128 (2007) 397–412.
- [4] J.-P. Bibring, M.G.G.T. Taylor, C. Alexander, U. Auster, J. Biele, A. Ercoli Finzi, F. Goesmann, G. Klingelhofer, W. Kofman, S. Mottola, K.J. Seidensticker, T. Spohn, I. Wright, Philae’s First Days on the Comet, *Science*, 349 (2015) 493.

- [5] J. Biele, S. Ulamec, Capabilities of Philae, the Rosetta Lander, *Space Science Reviews*, 138 (2008) 275–289.
- [6] W.H. Blume, Deep impact mission design, *Space Science Reviews*, 117 (2005) 23–42.
- [7] D.E. Brownlee, P. Tsou, D. Burnett, B. Clark, M.S. Hanner, F. Horz, M. Zolensky, The STARDUST mission: returning comet samples to Earth, *Meteoritics and Planetary Science Supplement*, 32 (1997) 22.
- [8] C. Dainese, A. Ercoli Finzi, F. Malnati, Test Facility for SD2 Comet Sampler Performance Improvement, 9th ESA Workshop on Advanced Space Technologies for Robotics and Automation, ESTEC, Noordwijk, The Netherlands (2006).
- [9] P. Di Lizia, P. Francesconi, F. Malnati, F. Bernelli-Zazzera, A. Ercoli-Finzi, Rosetta Mission: On-Comet Operation Planning for the Sampler, Drill and Distribution Subsystem, CEAS 2011 Conference Proceedings, (2011) 1752–1761.
- [10] A. Ercoli Finzi, P.G. Magnani, E. Re, S. Espinasse, A. Olivieri, SD2–How to Sample a Comet, *Space Science Reviews*, 128 (2007) 281–299.
- [11] P. Francesconi, F. Malnati, A. Ercoli-Finzi, SD2, a Technological/Scientific Instrument to Understand a Comet, *Journal of Aerospace Science, Technology and Systems*, 88 (2010) 129–138.
- [12] F. Goesmann, private communication, November 2015.

- [13] S. Mottola, G. Arnold, H.G. Grothues, R. Jaumann, H. Michaelis, G. Neukum, J.P. Bibring, The ROLIS Experiment on the Rosetta Lander, *Space Science Reviews*, 128 (2007) 241–255.
- [14] E. Remetean et al., Philae Locating and Science Support by Robotic Vision Techniques, *Acta Astronautica*, this issue.
- [15] H. Rosenbauer, S.A. Fuselier, A. Ghielmetti, J.M. Greenberg, F. Goesmann, S. Ulamec, G. Israel, S. Livi, J.A. MacDermott, T. Matsuo, C.T. Pillinger, F. Raulin, R. Roll, W. Thiemann, The COSAC experiment on the Lander of the ROSETTA mission, *Advances in Space Research*, 23 (1999) 333–340.
- [16] T. vonRosenvinge, J.C. Brandt, R.W. Farquhar, The International Cometary Explorer Mission to Comet Giacobini-Zinner, *Science*, 232 (1986) 353–356.
- [17] J.F.J. Todd, S.J. Barber, I.P. Wright, G.H. Morgan, A.D. Morse, S. Sheridan, M.R. Leese, J. Maynard, S.T. Evans, C.T. Pillinger, D.L. Drummond, S.C. Heys, S.E. Huq, B.J. Kent, E.C. Sawyer, M.S. Whalley, N.R. Waltham, Ion trap mass spectrometry on a comet nucleus: the Ptolemy instrument and the Rosetta space mission, *J. Mass Spectrom.*, 42 (2007) 1–10.
- [18] S. Ulamec, A. Balazs, J. Biele, S. Espinasse, C. Fantinati, C., H.-H. Fischer, Rosetta Lander - System Status after Five Years in Space, *Journal of Aerospace Science, Technology and Systems*, 88 (2010), 121–128.