



POLITECNICO
MILANO 1863

RE.PUBLIC@POLIMI

Research Publications at Politecnico di Milano

This is the published version of:

G. Campanardi, D. Grassi, A. Zanotti, E.M. Nanos, F. Campagnolo, A. Croce, C.L. Bottasso
Stereo Particle Image Velocimetry Set up for Measurements in the Wake of Scaled Wind Turbines

Journal of Physics: Conference Series, Vol. 882, 2017, 012003 (7 pages)
doi:10.1088/1742-6596/882/1/012003

The final publication is available at <http://dx.doi.org/10.1088/1742-6596/882/1/012003>

When citing this work, cite the original published paper.

Permanent link to this version

<http://hdl.handle.net/11311/1032047>

Stereo particle image velocimetry set up for measurements in the wake of scaled wind turbines

Gabriele Campanardi¹, Donato Grassi¹, Alex Zanotti¹, Emmanouil M Nanos², Filippo Campagnolo², Alessandro Croce¹, Carlo L Bottasso^{1,2}

¹ Politecnico di Milano, Dipartimento di Scienze e Tecnologie Aerospaziali, via La Masa 34, I-20156, Milano, Italy

² Technische Universität München, Lehrstuhl für Windenergie, Boltzmannstraße 15, D-85748 Garching bei München, Germany

E-mail: gabriele.campanardi@polimi.it

Abstract. Stereo particle image velocimetry measurements were carried out in the boundary layer test section of Politecnico di Milano large wind tunnel to survey the wake of a scaled wind turbine model designed and developed by Technische Universität München. The stereo PIV instrumentation was set up to survey the three velocity components on cross-flow planes at different longitudinal locations. The area of investigation covered the entire extent of the wind turbines wake that was scanned by the use of two separate traversing systems for both the laser and the cameras. Such instrumentation set up enabled to gain rapidly high quality results suitable to characterise the behaviour of the flow field in the wake of the scaled wind turbine. This would be very useful for the evaluation of the performance of wind farm control methodologies based on wake redirection and for the validation of CFD tools.

1 Introduction

In the recent years particle image velocimetry (PIV) for measurements on scaled wind turbines models was extensively used with various purposes. In particular, the use of a stereoscopic PIV set up enables to survey the wake extent at different cross-sections in order to study wake instabilities and the development of the flow in the near and the far wake of the wind turbine scaled model [1]. Moreover, this measurement technique was also useful to capture flow structures developed from the blade tip and root [2].

In the present paper, a new stereo PIV set up, purposely designed to survey the wake of scaled wind turbine models in the large wind tunnel of Politecnico di Milano (POLIMI), is described. In particular, the present set up was used to survey the three velocity components on cross-flow planes at different longitudinal locations behind a scaled wind turbine model designed and developed by Technische Universität München (TUM). The main scope of the present tests was to evaluate the capabilities of the present set up to gain rapidly high quality measurements for the characterisation of the behaviour of the flow field in the wake of the scaled wind turbine model. This result was considered very interesting for several goals. The former is to study the performance of wind farm control methodologies developed by TUM based on wake redirection. Indeed, this strategy is currently one of the most promising wind farm control methodologies which may lead to improved power capture and reduced structural loading. The current research on wake redirection is very active and covers high-



fidelity numerical simulations [3] in addition to scaled experiments in the wind tunnel [4]. Thus the present test results provided also an interesting data base useful for the validation of CFD tools purposely developed for these studies.

2 Experimental Set Up

2.1 The wind turbine model

The scaled wind turbine model used in the present tests has a 1.1 m rotor diameter and was designed and developed by TUM. The layout of the wind turbine model is presented in Fig. 1.

The model is characterized by a realistic aerodynamic performance, both at the airfoil and rotor levels, and its wake is in good accordance in shape, deficit and recovery with those of full-scale machines. Moreover, the model features active individual pitch, torque and yaw control that, together with a comprehensive onboard sensorization of the machine (including measures of shaft and tower loads), enables the testing of modern control strategies. Indeed, the model is controlled by a M1 Bachmann module that executes, similarly to what is done on real scale wind turbines, hard-real-time control laws similar to the ones described in Bossanyi [5].

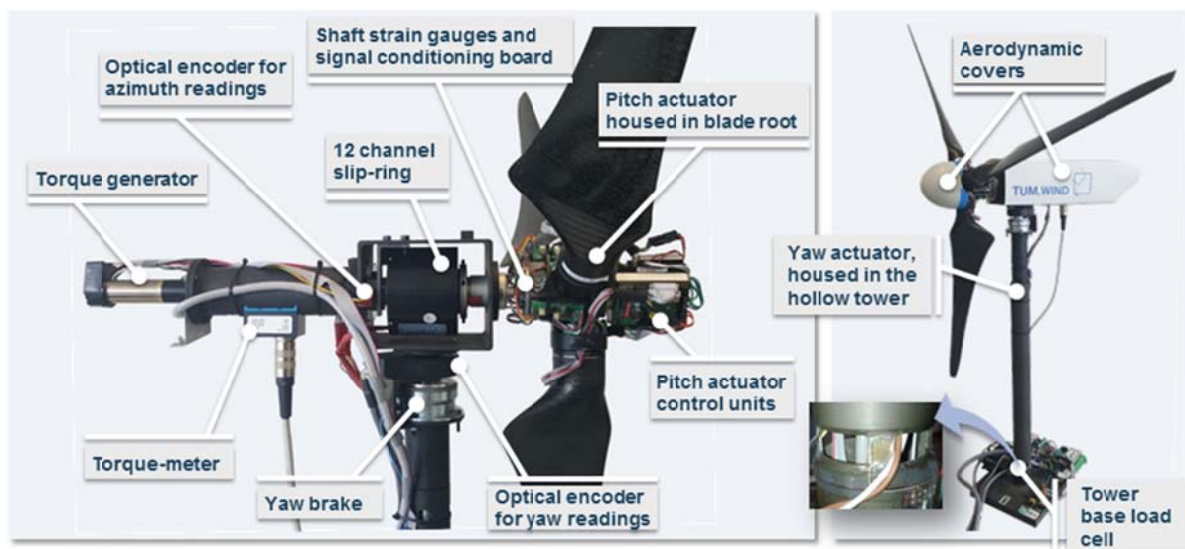

Figure 1: Layout of the scaled wind turbine model designed and developed by Technische Universität München

2.2 The wind tunnel

The Politecnico di Milano large wind tunnel presents a closed-circuit configuration, arranged in a vertical layout with two test sections in the loop (see the layout in Fig. 1). This facility has two different test chambers: a 4 m x 3.84 m aeronautical test section located downstream a settling chamber and a contraction and characterized by a very good flow quality (freestream turbulence level less than 0.1%) and a 13.84m x 3.84m wind engineering test chamber located in the return duct characterized by a stable floor boundary layer thickness in the order of 0.4 m and a mean turbulence level in the order of 2%. The experimental study of scaled wind turbine performance was carried out in the latter test chamber (boundary layer test section). Indeed, due to the larger dimensions, this choice enables to reduce to the minimum the blockage and the interference with the boundaries so allowing tests also for wind farm configurations. For further details about the wind tunnel facility please see Gibertini *et al.* [6].

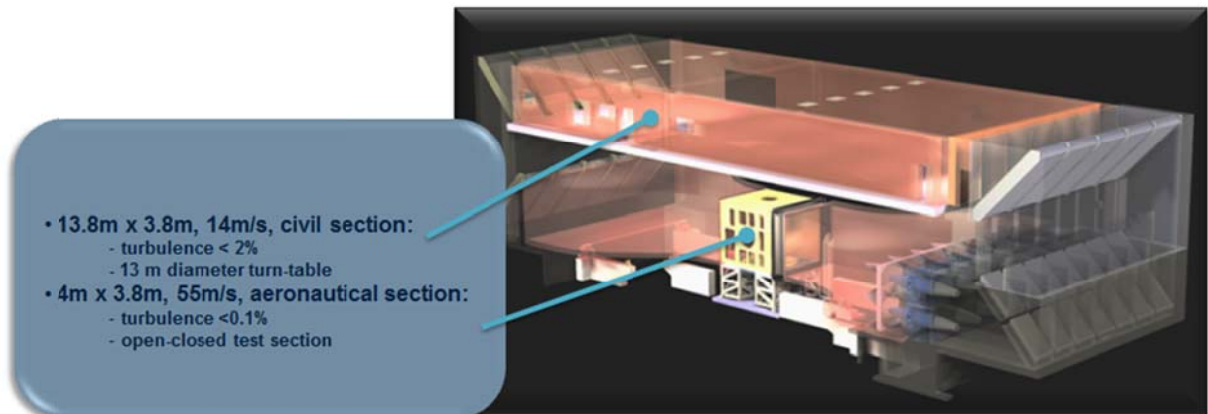

Figure 2: Layout of the Politecnico di Milano large wind tunnel

2.3 Stereo particle image velocimetry set up

The PIV instrumentation was set up to survey the three velocity components (u, v, w) on cross-flow (x - z) planes at different longitudinal locations (along x -axis) behind the wind turbine model rotor disk. In particular, in the here described test campaign two PIV measurement planes were considered, respectively located at $0.56 D$ and $6 D$ past the rotor disk.

The stereo PIV instrumentation comprised a Litron NANO-L-200-15 Nd:Yag double pulsed laser with a 200 mJ output energy and a wavelength of 532 nm, and two Imperx ICL-B1921M CCD cameras with a 12 bit, 1952×1112 pixel array [7]. Each camera was equipped with a Nikkor 50 mm lens and tilting type lens for correct focusing of the measurement window. The tilting lens mountings were adjusted in order to achieve the Scheimpflug condition. The camera separation angle was set to 40° . The layout of the instrumentation set up in the boundary layer test section of the POLIMI wind tunnel is shown in Fig. 3.

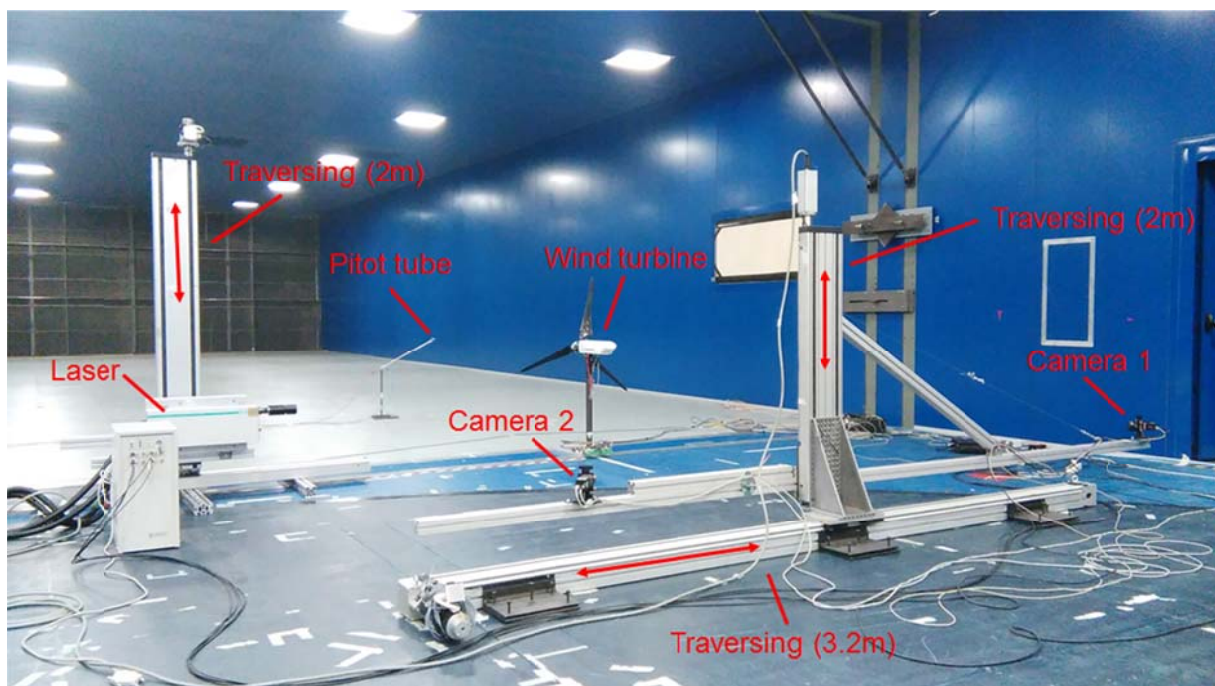

Figure 3: Stereo PIV set up in the Boundary Layer Test Section (14m x 4m) of POLIMI wind tunnel

The measurement planes covered the entire extent of the wind turbines wake and in order to achieve a higher resolution of the velocity survey, the entire measurement area was composed by several windows with a certain overlapping band between them. In particular, the area of investigation on the measurement plane at $0.56 D$ was $1586 \text{ mm} \times 1032 \text{ mm}$ and was composed by twelve measurement windows (arranged as four rows and three columns, see the layout in Fig. 4a) covering $786 \text{ mm} \times 427 \text{ mm}$ each. On the other hand, the area of investigation on the measurement plane at $6 D$ was $1786 \text{ mm} \times 830 \text{ mm}$ and was composed by fifteen measurement windows (arranged as three rows and five columns, see the layout in Fig. 4b) with the same dimensions ($786 \text{ mm} \times 427 \text{ mm}$ each).

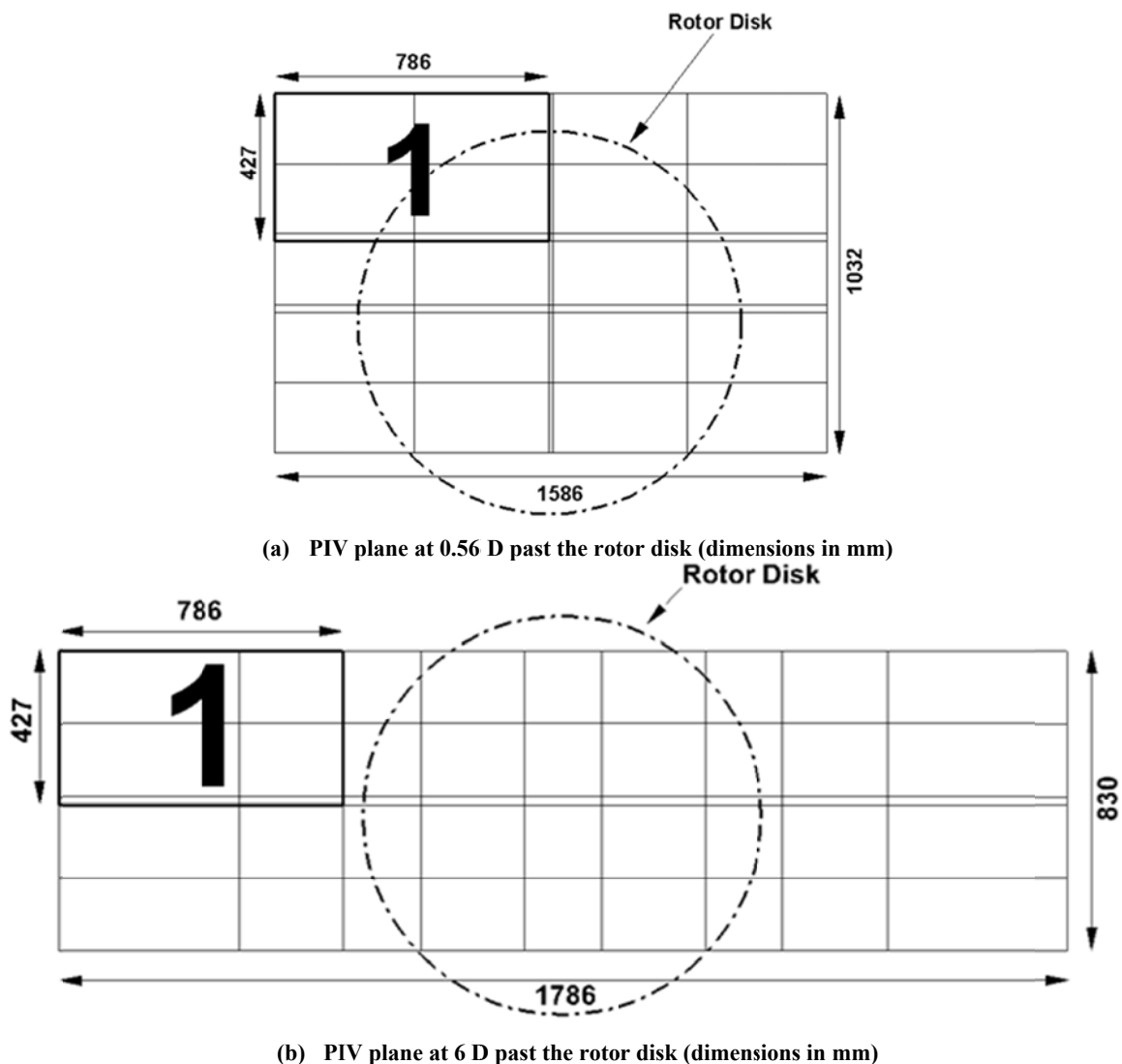

Figure 4: Layout of the PIV measurement planes, the dimensions of the measurement windows are shown for the upper-left window denoted with bold 1)

A rapid survey of the entire measurement area was obtained by the use of two separate traversing systems for both the laser and the cameras. In particular, as can be observed from the layout in Fig. 3, the two cameras were connected by a metallic arm and mounted to a 3.2m

x 2m double axis traversing system to move the cameras along the y and z -axis. The laser was also mounted on a traversing system to move the laser sheet along z -axis simultaneously with the measurement window. This solution enables to scan rapidly the large measurement area allowing a proper lighting of each window to ensure high quality results on the whole area. The synchronization of the two laser pulses with the image pair exposure was controlled by a 6-channels Quantum Composer QC9618 pulse generator. The digital images were captured using a GigaEthernet EBus connection. The calibration of the stereo PIV system was performed using a unique calibration grid covering the entire measurement area positioned in correspondence of the measurements planes (see Fig. 5). Thus, the calibration was performed for each measurement window moving the cameras with the traversing system.



Figure 5: Calibration of the stereo PIV system

The test chamber was fulfilled with the seeding using two particle generators with Laskin atomizer nozzles (PIVpart30 by PIVTEC) located downstream the wind turbine model. The particles consisted of small DEHS oil droplets with a diameter in the range of 1-2 μm .

The image pair analysis was carried out using PIVview 3C software [8], developed by PIVTEC in close cooperation with the PIV-Groups of the German Aerospace Center (DLR) in Gottingen and Koln. The image pairs were post-processed using the multigrid interrogation algorithm [9] with a final interrogation window of 96 pixels \times 96 pixel. In particular, two hundreds image pairs were acquired for each measurement window. This choice was considered a fair compromise to obtain a reliable ensemble average for the velocity field and a contained run time taking into account the large area to be scanned during the test. The accuracy of the present PIV measurements can be estimated considering a maximum displacement error of 0.1 pixels [7]. Thus, taking into account the employed pulse-separation time and the optical magnification [10], the maximum out-of-plane velocity components error is about 0.1 m/s.

3 Test Results

The PIV surveys were performed with a rated rotor rotational speed of 850 RPM and a wind tunnel freestream velocity (U_∞) of 5.95 m/s. In the present paper sample results of the test campaign obtained with the wind turbine model operating without wake redirection control are presented. In particular, Figs. 6 and 7 show the contours of the ensemble average of the streamwise velocity component (u) respectively for the measurement planes at 0.56 D and 6 D past the rotor disk. In particular, on the

plane at $0.56 D$ past the rotor disk measurements are missing in two areas on the left and on the right of the rotor disk (depicted in white on Fig. 6), where, due to the close proximity of the measuring plane with the wind turbine, part of the nacelle was visible on the background of the image pairs, leading to bad correlation between the images.

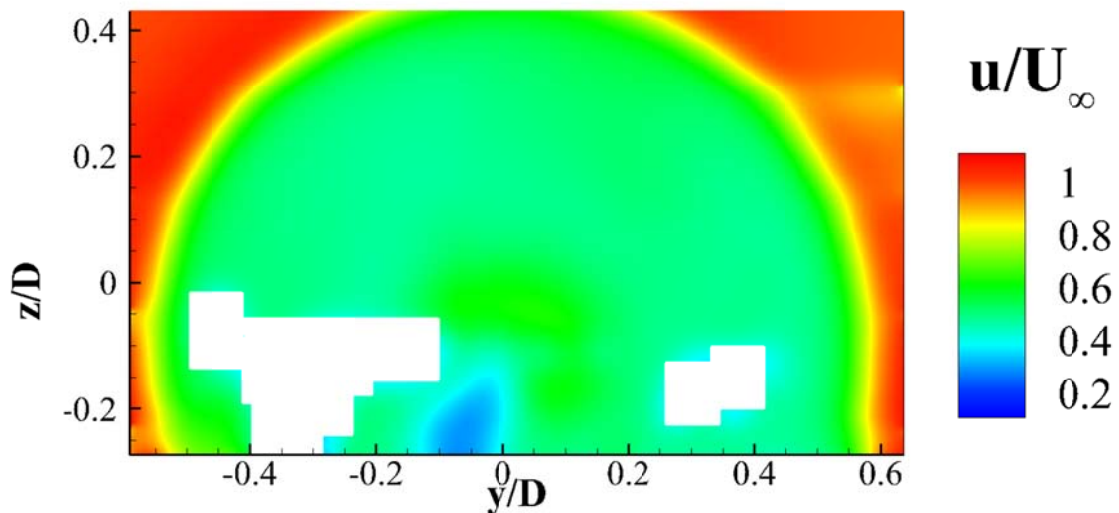

Figure 6: Normalized averaged streamwise velocity component on the yz -plane at $0.56D$ past the rotor disk

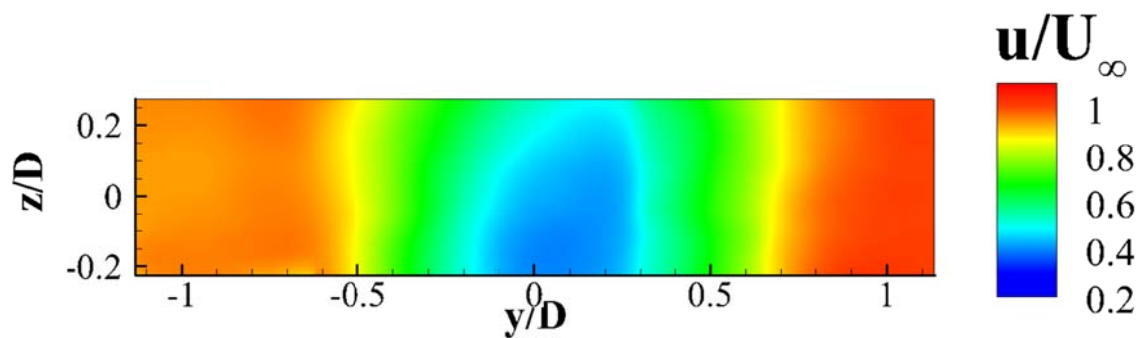

Figure 7: Normalized averaged streamwise velocity component on the yz -plane at $6D$ past the rotor disk

The overall flow fields shows very high quality results obtained for both the measurement planes. The sample results presented in this paper show clearly the streamwise evolution of the wind turbine wake. In particular, on the measurement plane at $0.56 D$ past the rotor disk, an apparent gradient of the streamwise velocity is visible close to the blade tip passage region, while inside the rotor disk wake the velocity field is quite uniform except in the region of the nacelle wake (see Fig. 6). On the other hand, an apparent increase of the nacelle wake is appreciable from the measurement results obtained on the plane at $6 D$ past the rotor disk (see Fig. 7).

4 Conclusions

A new stereo PIV set up was developed and tested at the large wind tunnel of POLIMI for the application of wake surveys on scaled wind turbine models. The set up enables to rapidly scan the entire extent of the wind turbine wake by the use of two separated traversing systems for both the laser and the cameras. The wind tunnel campaign provided high quality results that enabled to investigate the behaviour of the flow field in the wake of the scaled wind turbine useful for the evaluation of the performance of wind farm control methodologies based on wake redirection developed by TUM.

Moreover, the present experimental data base was used for the validation of CFD tools purposely developed by TUM for these studies.

Acknowledgements

This project was partly funded by the EU Horizon 2020 research and innovation programme under the Marie Skłodowska-Curie grant agreement No. 642108.

References

- [1] Naumov I V, Mikkelsen R F , Okulov V L and Sørensen J N 2014 PIV and LDA measurements of the wake behind a wind turbine model *The Science of Making Torque from Wind 2014 (TORQUE 2014) IOP Publishing Journal of Physics: Conference Serie* vol 524
- [2] Meyer K E, Naumov I V, Kabardin I, Mikkelsen R and Nørkær Sørensen J 2013 PIV in a model wind turbine rotor wake *10th International Symposium on Particle Image Velocimetry (PIV13)* Delft, The Netherlands, July 1-3, 2013
- [3] Fleming P, Gebraad P, Lee S, van Wingerden J W, Johnson K, Churchfield M, Michalakes J, Spalart P and Moriarty P 2014 Evaluating techniques for redirecting turbine wakes using sowfa *Renewable Energy* vol 70 pp 211-218
- [4] Campagnolo F, Petrovi_c V, Bottasso C L and Croce A 2016 Wind tunnel testing of wake control strategies *Proceedings of the American Control Conference* pp 513-518
- [5] Bossanyi E 2000 The design of closed loop controllers for wind turbines *Wind Energy* vol 3 pp 149-163
- [6] Gibertini G, Gasparini L, and Zasso, A 1997 Aerodynamic design of a civil-aeronautical low speed large wind tunnel *AGARD 79th Fluid Dynamics Panel Symposium* Moscow, Russia, 30 Sept.-3 Oct. 1996, pp 6.1-6.10
- [7] Zanotti A, Ermacora M, Campanardi G and Gibertini G 2014 Stereo Particle Image Velocimetry Measurements of Perpendicular Blade-Vortex Interaction over an Oscillating Airfoil *Experiments in Fluids* vol 55 (9) pp 1-13
- [8] PIVview 2C/3C, User Manual, PIVTEC, www.pivtec.com
- [9] Raffel M, Willert C, Wereley S and Kompenhans J 2007 *Particle Image Velocimetry - A Practical Guide* Springer Verlag, Berlin
- [10] De Gregorio F, Pengel K and Kindler K 2012 A comprehensive PIV measurement campaign on a fully equipped helicopter model *Experiments in Fluids* vol 53 pp 37-49