

71st Conference of the Italian Thermal Machines Engineering Association, ATI2016, 14-16  
September 2016, Turin, Italy

## Preliminary study of pyrolysis and gasification of biomass and thermosetting resins for energy production

Davide Bonalumi\*

*Politecnico di Milano, Dip. Energia, Via Lambruschini 4A, 20156, Milano, Italy*

---

### Abstract

The gasification of the biomass is an efficient way to employ the renewable source for the production of electric power. Nevertheless, the water content in the biomass can be very high and the performances of a power plant that exploits the syngas produced can be negatively affected. The mixing of thermosetting resin with the biomass in order to increase the performances even with high moisture of the biomass is evaluated in a two stage gasifier. An Aspen Plus model that simulates the sub-processes of the gasification is implemented. The equations that describe the pyrolysis and the gasification are regressed with the data available in literature. The power production obtained with a mixture of 30% of thermosetting resins and biomass with 65% of water is higher than the ones obtained with biomass with 45% of water.

© 2016 The Authors. Published by Elsevier Ltd. This is an open access article under the CC BY-NC-ND license (<http://creativecommons.org/licenses/by-nc-nd/4.0/>).

Peer-review under responsibility of the Scientific Committee of ATI 2016.

*Keywords:* Pyrolysis; Gasification; Biomass; Thermosetting; Gasifier; Aspen Plus; Cold Gas Efficiency; Power Production; Electricity.

---

### 1. Introduction

The efficient utilization of biomass is important to replace a significant amount of fossil fuels used for the energy production. Biomass gasification produces a fuel gas that coupled with advanced power generation systems, such as gas turbines or fuel cells, offers high efficiencies as proposed by Doherty et al. in 2015 [1]. The gasification of the

---

\* Corresponding author. Tel.: +39-02-2399-3817; fax: +39-02-2399-3913.  
*E-mail address:* [davide.bonalumi@polimi.it](mailto:davide.bonalumi@polimi.it)

biomass may be described by a sequence of processes in function of the temperature as proposed in [2]: drying (at 100–200°C), pyrolysis (at 200–700°C), gasification (700–900°C) and combustion (above 800°C). These processes are not strictly defined and they often overlap in function of the considered technology. Drying and pyrolysis occur heating up the biomass without addition of any form of oxygen. The gasification and combustion take place introducing an amount of oxygen in some form. Among these processes the description of the pyrolysis process is considered particularly challenging because it evolves a great deal of physical and chemical transformations and produces a large number of product species as stated by Neves et al [2]. These authors propose empirical relationships for pyrolytic products distribution and properties in function of the temperature. The products of the pyrolysis can be classified in this type: solid (mostly char or carbon), liquid (tars, heavier hydrocarbons and water), gas ( $\text{CO}_2$ ,  $\text{H}_2\text{O}$ ,  $\text{CO}$ ,  $\text{C}_x\text{H}_y$ , etc.). The choice of the technology affects the gasification sub-processes. In two-stage gasifier pyrolysis and gasification take place in separate reactors. An examples of this scheme of plant is investigated by Teixeira et al. [3], they considered a screw conveyer in which the pyrolysis occurs. Similar layout is proposed in the work of Henriksen et al. [4], they present the results of a demonstrative two-stage gasifier of 75 kW. The interest on this scheme of plant is due to the low tar content in the fuel gas produced.

Beside the exploitation of the biomass as renewable energy resources, the waste gasification is an eco-friendly way to reduce fossil-fuel consumption. In particular, waste pyrolysis/gasification of materials like the thermosetting resins can represent a technique to convert wastes into syngas useful as fuel gas. Thermoset polymers do not permanently harden over a critical temperature and do not soften when they are re-heated. The materials degrade and decompose before they can reach temperatures high enough to melt. These types of resins are not completely recyclable as feedstock in the same industrial field. Feedstock recycling, which converts plastic materials into useful basic chemicals, has been recognized as an advanced technology process. Gasification is one example of these feedstock recycling technologies, which converts carbonaceous materials into a combustible gas, that can be applied for heating and power generation. Ongen [5] investigates this option in his work obtaining a methane-rich syngas with high heating value. Yun et al. [6] applied the pyrolysis for glass fiber-reinforced plastic (GFRP) and Pickering [7] proposes the recovery of the fibers from thermoset composite material obtaining syngas. With the gasification of plastic particular attentions are for the high production of tar, as reported in [8] and [9].

A complete description of the main reactions involved in the gasification process and their role are well proposed by Cau et al. [10]. Gasification is generally carried out by injecting sub-stoichiometric air or oxygen (just to promote the combustion of a portion of fuel to provide heat for the endothermic reactions) and eventually steam. In general, an increasing of air (or oxygen) injection promotes fuel combustion, thus involving an increasing temperature of the process, higher  $\text{CO}_2$  concentrations and lower  $\text{CO}$  concentrations in raw syngas. On the other hand, an increasing in steam injection involves a temperature reduction and promotes shift conversion equation, with a subsequent increasing in  $\text{H}_2$  and  $\text{CO}_2$  concentrations in raw syngas despite a reduction of  $\text{CO}$  content. The role of the water is important in the products obtained and also in the whole energy balance. In fact, the biomass moisture evaporation is a high energy demand process. However, for high content of moisture, steam is not required and this can simplify the plant layout, especially for small-scale plants. On the other hand, higher moisture lower heating value of the syngas.

The modeling of the gasification sub-process is investigated in several works. Less references are available for the pyrolysis sub-process. This paper presents a complete simulation from the pyrolysis and the gasification for energy production with the evaluation of the energy performances of the whole plant. The chemicals produced in the sub-process are defined with equations regressed with experimental data retrieved from the literature. Due to the high heating value of the syngas obtained with the gasification of the thermosetting resins is investigated the strategy of mixing this type of resins to high-moisture biomass. It is expected the increasing of the heating value of the syngas with respect to the one obtained with only biomass. The results are work out implementing a plant in the simulation software Aspen Plus, already applied by the author [11], [12].

## 2. Technology

This paragraph describes the technology considered to exploit the biomass and the mixture of the biomass and the thermosetting resins. The obtained syngas is exploited as fuel gas in a gas engine to produce electricity. The process considered is based on a two-stage gasifier similar to the Danish small-scale (75 kW thermal) called *Viking* presented by Henriksen et al. [4].

### 2.1. Pyrolysis unit

The material (biomass or biomass & resin) is fed to the screw conveyor that brings the material from the container with the material to the gasifier reactor. In the screw conveyor take place both the drying process and the pyrolysis process. In the first part of the pyrolysis reactor, the biomass is dried. In the second part, the pyrolysis takes place. Pyrolysis demands higher temperatures than drying, and to satisfy this, the exhaust gas of the engine goes countercurrent respect the screw motion as proposed in Figure 1. The maximum temperature at the end of the pyrolysis is fixed to 450°C. In the case in which the heat of the exhaust engine is not enough a part of syngas can be burnt and the heat exchanged with the pyrolyzer.

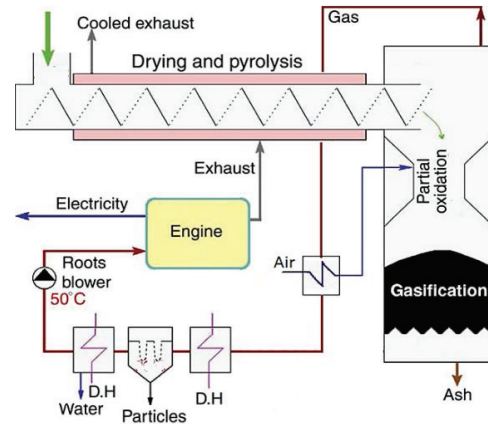

Figure 1 Scheme of plant of the two-stage gasifier investigated in this study (modification of the scheme proposed in [4])

### 2.2. Gasification unit

The gasification reactor is fed over the middle part with all the pyrolysis products: syngas, tar and char. Falling into the reactor the heavier parts meet the ascending hot syngas produced on the bottom. In this way the tar and the char heat up exploiting the higher temperature of the gasification syngas. The maximum temperature in the reactor is fixed at 900°C in the region of the oxidation. The syngas here produced mixes with the one coming from the pyrolysis process at the top of the reactor. The merged syngas exchanges heat into a pre-heater of the air of the gasifier.

### 2.3. Gas treatment unit and engine

The plant is thought to gasify some plastic materials that have the peculiarity of increasing the heating value of the syngas, but also to increase the production of tar as documented in the works of Mastellone et al. [9] and Arena et al. [13]. The two-stage layout limits the tar formation, but to avoid the presence of them in the syngas it is treated in a cleaning section. The syngas exiting the gasifier is quenched with sprayed water in a scrubber reducing the temperature around above the water dew point (about 90°C) hence it passes in a bag house filter. After this the gas is cooled further down to about 50°C and the condensate is removed. The gas flow is driven by a blower that overcomes the pressure drops. The cleaned fuel gas is exploited in a combustion engine with an electric efficiency of the 39% (as reference engine the *Jenbacher Type 2* is considered). The exhaust gas at about 470°C are passed around the walls of the pyrolyzer to maintain the temperature of the process.

## 3. Modeling

The plant is simulated with the software Aspen Plus with a thermodynamic equilibrium model. This approach allows the calculation of the theoretical production that can be attained for the chemicals involved in the process.

In this work the chemical equilibrium is determined based on: (i) the equilibrium constant; (ii) the minimization of the Gibbs free energy. The model calculates the temperature, the gas composition and the production of char for the input conditions. In Aspen Plus are available unit operation blocks, such as reactors, heaters, pumps, etc. These blocks are connected using material and energy streams to study a process. The simulation calculations are performed using the in-built physical properties database. The modelling of the gasification plant is studied in sub-processes: the drying and pyrolysis, the gasification, the cleaning of the syngas, the energy production with an internal combustion engine and an auxiliary burner. The process flow sheet diagram is represented in Figure 2.

The chemical products obtained in the sub-processes are validated with the experimental data available in literature [2]–[4]. The properties of the conventional components defined in Aspen Plus are estimated adopting the Peng–Robinson equation of state with Boston–Mathias alpha function (PR–BM) as adopted in other works [14], [15]. For

the estimation of the enthalpy and density for both biomass and ash, which are non-conventional components, HCOAL-GEN and DCOALIGT models were used.

The biomass and the resins fed to the plant are considered as non-conventional components as well as the char and the ash obtained as products of the process. For these components are specified the ultimate, the proximate and the sulfur analysis. The air considered in the simulation is defined as 79% vol of N<sub>2</sub> and 21% vol of O<sub>2</sub>.

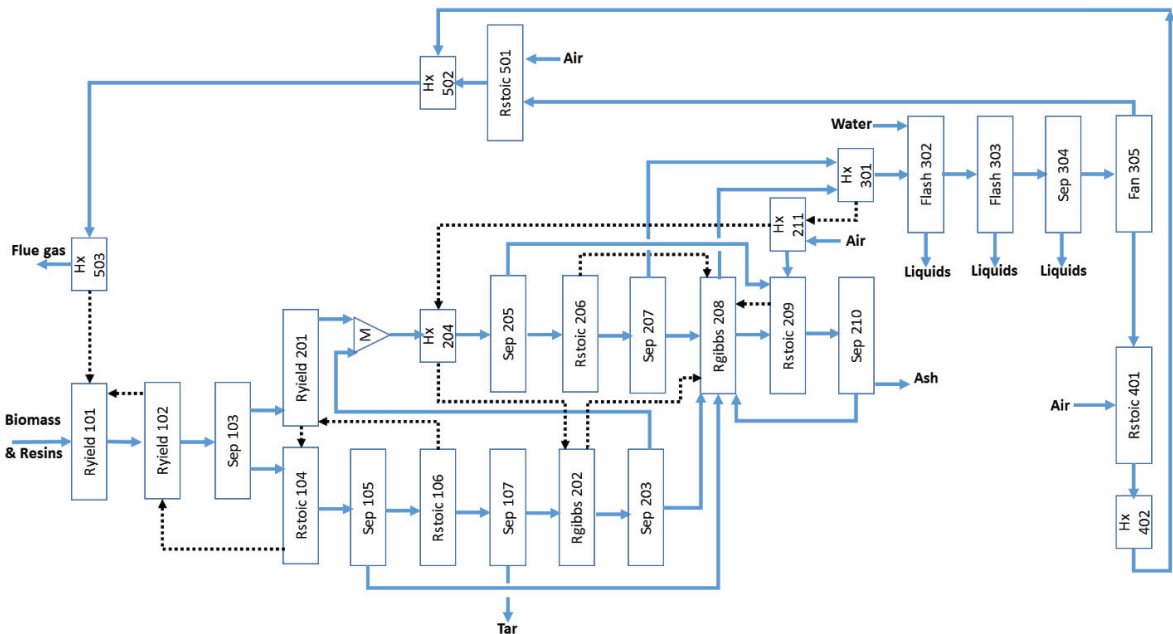

Figure 2 Process flow diagram implemented in Aspen Plus. Blue lines indicate mass streams; the dashed black lines indicate heat streams. With rectangular shapes are represented the unit operation blocks used in Aspen Plus. Inside them is reported the name of the component defined in Aspen Plus and beside the name there is a numeration. 1xx are the blocks used to simulate the pyrolysis process; 2xx are the blocks used to simulate the gasification process; 3xx are the blocks used to simulate the cleaning process of the syngas; 4xx are the blocks used to simulate the engine; 5xx are the blocks used to simulate the presence of a thermal integration in case the heat available in the flue gas is not sufficient for the drying/pyrolysis step.

### 3.1. Chemical components involved in the process

The products that can be formed in the sub-processes are defined from the experimental data gathered in the cited literature, the yield is defined with regressed equations implemented in the *Calculator Block* of Aspen Plus. The main step is the determination of the products transformed by the non-conventional components. In particular, several chemical compounds are produced in the pyrolysis. They can be divided by type: (i) char; (ii) tar; (iii) syngas. The yield of each type of compounds is evaluated in function of the pyrolysis temperature. From literature, in particular [2], is observed that at temperatures around 300°C char is the main product; at the range temperatures 450°C – 550°C a maximum of tar is observed; the increasing of temperature favors the production of light gases, especially at temperatures higher than 800°C. The information related to the pyrolysis of the thermosetting resins are based on the work proposed by [16]. Each type of compound is studied to determine its composition and the trend in function of the temperature is regressed to have equations that can be easily implemented in the *Calculator Block* of the software Aspen Plus. The char can be characterized by the ultimate (the elements) and proximate analysis: (i) the volatile matter, (ii) the fixed carbon, (iii) the ash. The composition of the tar is very broad, around 180 chemicals are mentioned in the cited works. In this investigation they are subdivided in families of compounds and representative chemicals are considered as possible products in Aspen Plus, in particular they are divided in: alcohols, aldehydes, ketones, furans, phenols, poly-benzenes and levoglucosan. Also the composition of the syngas is determined by the results

available in literature. The main products of the gas pyrolysis are the CO and the CO<sub>2</sub>, lower content of CH<sub>4</sub>, H<sub>2</sub> and C<sub>x</sub>H<sub>y</sub> are observed. Increasing the temperature more gas is produced.

### 3.2. Pyrolysis

Within the modelling this sub-process converts the biomass, defined as non-conventional component, both in conventional and non-conventional components. The first block is a *Ryield 101* that, at ambient temperature, produces ash as non-conventional component and other conventional components of the biomass and resins: C, H<sub>2</sub>, N<sub>2</sub>, S, Cl<sub>2</sub>, O<sub>2</sub>, H<sub>2</sub>O and ash. The reactor is managed with the *Calculator Block*. The elements are converted in char by means of the following *Ryield 102* based on the ultimate, proximate, sulfur-analysis determined with the regressed equations. The char and the conventional components, are separated in the block *Sep 103*. The conventional products are elaborated in the *Rstoic 104* in which are defined the reactions that produce the gases with the relations regressed. The amount of the conventional components unreacted and separated in *Sep 105* are converted in tar components in the *Rstoic 106*. The chemical reactions to obtain the considered substances are defined by the regression based on the data retrieved in the literature. A part of some chemicals of the tar are separated in the *Sep 107* to take into account that the plant produces a quantity of tar that does not undergo further modifications. The heat required for the pyrolysis is obtained by the combustion of the syngas in the internal combustion engine. In the *Ryield 101* are concentrated the thermal losses due to the heat dispersions evaluated as the 2% of the exchanged heat by the flue gas.

### 3.3. Gasification

In this sub-process the char is decomposed in elements by means of the *Ryield 201* which is managed through a *Calculator Block*. The exiting stream is composed by elements: solid C, H<sub>2</sub>, N<sub>2</sub>, S, Cl<sub>2</sub>, O<sub>2</sub> and ash. It is jointed with the stream coming from the *Sep 203* that splits the gas and char produced by the *Rgibbs 202* converting part of the tar products. The mixed stream is heated up in the heat exchanger *Hx 204* with the heat of the syngas produced by the gasifier, as later explained. This stream is split up in two streams by *Sep 205*. The stream that contains S and Cl is transformed in the *Rstoic 206* to give H<sub>2</sub>S and HCl. The other one is exploited in a combustor represented by *Rstoic 209* to supply the necessary heat for the *RGibbs 208* which represents the gasifier. The amount of char split is determined by a *Design Specification* to maintain the temperature of 900°C in the gasifier. The stoichiometric air for its combustion is pre-heated (to 450°C) in the block *Hx 211* and the products of the combustion are divided in the *Sep 210* to eliminate the ash, while the gas is sent to the gasifier. To simplify the gasification process, the N<sub>2</sub>, H<sub>2</sub>S and HCl are separated in the *Sep 207* because they do not have a significant role in the main reactions that take part in the gasifier. The other stream composed by H<sub>2</sub>, O<sub>2</sub>, H<sub>2</sub>O and C is sent to the gasifier in which the chemical reactions considered are:

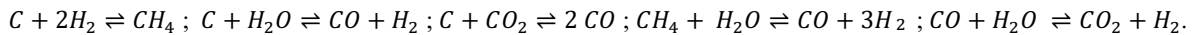

In this work the reactions are studied at the equilibrium at the temperature of 900 °C, but the one of methanation and the one of shift are calculated specifying the approach temperature of -265°C and -90°C respectively, in order to obtain a good agreement with the experimental data. Also the gas separated in the *Sep 105* is sent to the gasifier. The thermal losses in the gasifier are evaluated as the 3% of the exchanged heat.

### 3.4. Cleaning section, energy production and auxiliary burner

In this section the syngas is cooled to around 450°C in the *Hx 301*, then it is quenched with a stream of water at 25°C in order to decrease the temperature to 150°C in the *Flash 302*. In the *Flash 303* the syngas is further cooled to 50°C to condensate water and subsequently the *Sep 304* represents a filtration that lets to pass only the gas-phase. To cope the pressure losses of the plant the *Fan 305* increase the pressure of 1 bar. The cleaned syngas is sent to the internal combustion engine and a part can be directed to an auxiliary burner.

The syngas is exploited in an internal combustion engine of 250 kWe simulated with the *Rstoic 401* which calculates the combustion at 900°C. The 39% of the heat of combustion is considered as electric power production. The flue gas exits the engine at 470°C, this decreasing of temperature is worked out in the *Hx 402*. The stream of the flue gas is utilized in pyrolysis process to heat up the system.

In case in which the heat available in the flue gases, obtained by the internal combustion engine, was not sufficient for the pyrolysis process, part of the cleaned syngas can be exploited in a combustion at 900°C simulated with the *Rstoic 501*. The products are mixed with the flue gas coming from the internal combustion engine and the heat of the mixed gases is exploited in the pyrolysis process. The amount of syngas to burn in this section is accounted in a dedicated *Design Specification*.

### 3.5. Validation

The model implemented is validated comparing results calculated with the ones available for the *Viking* plant [4]. In this case only a mix of different types of biomass is considered as inlet at the plant. In Table 1 is reported the comparison.

Table 1 comparison of the composition

Composition (% mol)	Viking	This work
H2	32.0	32.6
N2	30.0	29.2
CO2	20.0	21.3
CO	15.0	14.2
CH4	3.0	2.7

The High Heating Value (HHV) for the syngas is calculated with Aspen Plus. For the Viking plant it results around 7.0 MJ/kg, while the one calculated for this work is of 6.9 MJ/kg.

## 4. Results and discussions

The model gives satisfactory results for the biomass gasification. It is utilized to analyze the performances in the case in which thermosetting resins are added to the biomass. In this section as indexes of merit are considered the Cold Gas Efficiency (CGE), the HHV and the electric efficiency. In this work the CGE is defined based on the HHV and the mass flow rate ( $\dot{m}$ ) of syngas and biomass, similarly to what is proposed in [17], and it is evaluated at the inlet of the internal combustion engine:

$$CGE = \frac{\dot{m}_{syngas} \cdot HHV_{syngas}}{\dot{m}_{biomass} \cdot HHV_{biomass}}$$

The electrical efficiency of the plant is defined on the Low Heating Value of the biomass (LHV):

$$\eta_{el,imp} = \frac{P_{el}}{\dot{m}_{biomass} \cdot LHV_{biomass}}$$

Where the  $P_{el}$  (electric power) is defined as:

$$P_{el} = \eta_{el,engine} \cdot (\dot{m} \cdot LHV)_{syngas} - P_{fan} - P_{aux}$$

The power required by the fan ( $P_{fan}$ ) is calculated in Aspen Plus, while the power required by the auxiliaries are:

$$P_{aux} = 0.02 \cdot (\dot{m}_{biomass} \cdot LHV_{biomass})$$

The biomass fed to the plant is obtained by mixing different kind of biomass characterized by the cited references while the thermosetting resin is the one reported in [5]. The characterizations are presented in Table 2.

Table 2 Proximate and ultimate analysis for the biomass and the thermosetting resins

	Proximate analysis		Ultimate analysis	
	Biomass, %	Thermosetting, %	Biomass, %	Thermosetting, %
Moisture	45.0	0.05	Carbon	53.2
Fixed Carbon	18.7	5.18	Hydrogen	6.2
Volatile Matter	78.5	93.65	Nitrogen	0.5
Ash	2.8	1.17	Chlorine	0.0
			Sulfur	0.1
			Oxygen	40.0
				80.93
				13.58
				0.20
				1.44
				0.00
				3.85

#### 4.1. Moisture effect on the CGE

The effect of the moisture on the biomass gasification is evaluated through the value of the CGE. The increasing of the moisture content in the biomass fed at the gasification plant plays an important role on the composition of the syngas and consequently on the CGE as reported on the left of the Figure 3. The CGE evaluated at the inlet of the internal combustion engine take into account that part of the syngas is not exploited in the engine, but is used for supplying the necessary heat at the pyrolysis process. The effect of the mixing of the thermosetting resins to the biomass is evaluated through the CGE depicted on the right of the Figure 3. The moisture of the mixture is fixed at 45% and the amount of resins is varied to obtain this value with the moisture of biomass in the range of 45-65%.

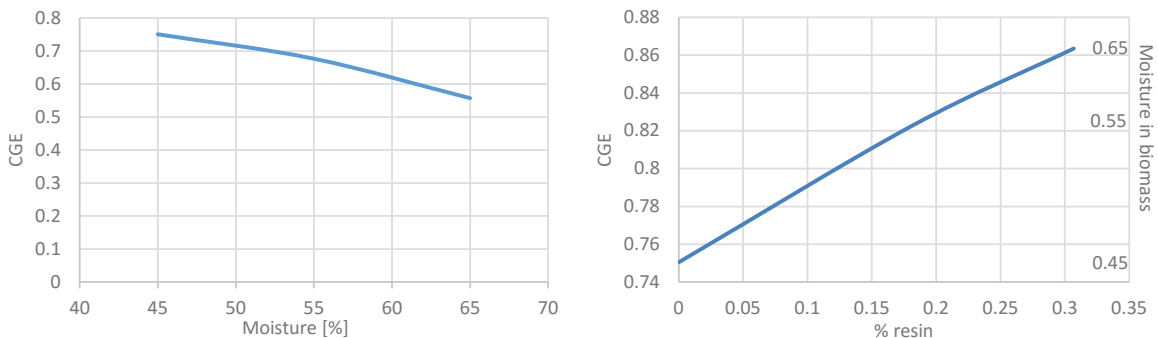

Figure 3 Cold Gas Efficiency function of the biomass moisture fed to the gasification plant on the left; Cold Gas Efficiency function of the content of thermosetting resins mixed with the biomass in order to have 45% of moisture on the right.

#### 4.2. Net electrical efficiency

The net power produced by the gasification plant is evaluated in function of the moisture content in the biomass in the range of 45-65% and in function of the amount of the thermosetting resin added to maintain the content of moisture in the mixture at 45%. The results are represented in Figure 4.

### 5. Conclusions and future works

A model for the simulation of a two-stage gasification plant for power production is proposed. The opportunity to use thermosetting resin to increase the efficiency of high moisture biomass is evaluated. With biomass at the 65% of moisture the addition of around 30% of resins makes possible to pass the 30% of the net electric efficiency with respect to around 17% with only biomass. Future activities will consider a more extensive parametric analysis.



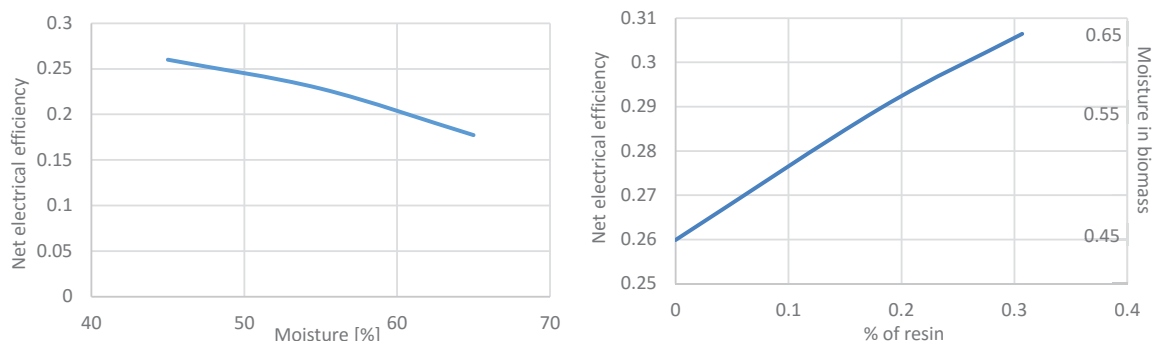

Figure 4 Net electric efficiency of the gasification plant in function of the biomass moisture on the left. Net electrical efficiency function of the content of thermosetting resin with the biomass in order to have 45% of moisture on the right.

## Referencesa

- [1] W. Doherty, A. Reynolds, and D. Kennedy, "Process simulation of biomass gasification integrated with a solid oxide fuel cell stack," *J. Power Sources*, vol. 277, pp. 292–303, 2015.
- [2] D. Neves, H. Thunman, A. Matos, L. Tarelho, and A. Gomez-Barea, "Characterization and prediction of biomass pyrolysis products," *Prog. Energy Combust. Sci.*, vol. 37, no. 5, pp. 611–630, 2011.
- [3] G. Teixeira, L. Van De Steene, E. Martin, F. Gelix, and S. Salvador, "Gasification of char from wood pellets and from wood chips: Textural properties and thermochemical conversion along a continuous fixed bed," *Fuel*, vol. 102, pp. 514–524, 2012.
- [4] U. Henriksen, J. Ahrenfeldt, T. K. Jensen, B. Gøbel, J. D. Bentzen, C. Hindsgaul, and L. H. Sørensen, "The design, construction and operation of a 75 kW two-stage gasifier," *Energy*, vol. 31, no. 10–11, pp. 1542–1553, 2006.
- [5] A. Ongen, "Methane-rich syngas production by gasification of thermoset waste plastics," *Clean Technol. Environ. Policy*, vol. 18, no. 3, pp. 915–924, 2016.
- [6] Y. M. Yun, M. W. Seo, H. W. Ra, G. H. Koo, J. S. Oh, S. J. Yoon, Y. K. Kim, J. G. Lee, and J. H. Kim, "Pyrolysis characteristics of glass fiber-reinforced plastic (GFRP) under isothermal conditions," *J. Anal. Appl. Pyrolysis*, vol. 114, pp. 40–46, 2015.
- [7] P. S.J., "Recycling technologies for thermoset composite materials—current status," *2nd Int. Conf. Adv. Polym. Compos. Struct. Appl. Constr.*, vol. 37, no. 8, pp. 1206–1215, 2006.
- [8] J. W. Kim, T. Y. Mun, J. O. Kim, and J. S. Kim, "Air gasification of mixed plastic wastes using a two-stage gasifier for the production of producer gas with low tar and a high caloric value," *Fuel*, vol. 90, no. 6, pp. 2266–2272, 2011.
- [9] M. L. Mastellone, L. Zaccariello, and U. Arena, "Co-gasification of coal, plastic waste and wood in a bubbling fluidized bed reactor," *Fuel*, vol. 89, no. 10, pp. 2991–3000, 2010.
- [10] G. Cau, V. Tola, and A. Pettinau, "A steady state model for predicting performance of small-scale up-draft coal gasifiers," *Fuel*, vol. 152, pp. 3–12, 2015.
- [11] C. M. Invernizzi, P. Iora, D. Bonalumi, E. Macchi, R. Roberto, and M. Caldera, "Titanium tetrachloride as novel working fluid for high temperature Rankine Cycles: Thermodynamic analysis and experimental assessment of the thermal stability," *Appl. Therm. Eng.*, vol. 107, pp. 21–27, Aug. 2016.
- [12] D. Bonalumi and A. Giuffrida, "Investigations of an air-blown integrated gasification combined cycle fired with high-sulphur coal with post-combustion carbon capture by aqueous ammonia," *Energy*, May 2016.
- [13] U. Arena, F. Di Gregorio, C. Amorese, and M. L. Mastellone, "A techno-economic comparison of fluidized bed gasification of two mixed plastic wastes," *Waste Manag.*, vol. 31, no. 7, pp. 1494–504, Jul. 2011.
- [14] W. Doherty, a. Reynolds, and D. Kennedy, "Aspen Plus Simulation of Biomass Gasification in a Steam Blown Dual Fluidised Bed," *Mater. Process Energy*, pp. 212–220, 2013.
- [15] N. Ramzan, A. Ashraf, S. Naveed, and A. Malik, "Simulation of hybrid biomass gasification using Aspen plus: A comparative performance analysis for food, municipal solid and poultry waste," *Biomass and Bioenergy*, vol. 35, no. 9, pp. 3962–3969, Oct. 2011.
- [16] P. T. Williams, "Thermal and Pyrolytic Processes for the Valorization of Waste Plastics," *ISFR 2011 Toledo*, pp. 5–7, 2011.
- [17] P. N. Sheth and B. V Babu, "Experimental studies on producer gas generation from wood waste in a downdraft biomass gasifier," *Bioresour. Technol.*, vol. 100, no. 12, pp. 3127–33, Jun. 2009.