

HOT-SPOT PHENOMENON IN PV SYSTEMS WITH OVERHEAD LINES PARTIAL SHADING

Alberto DOLARA¹, George Cristian LAZAROIU², Sonia LEVA³

This paper deals with the occurrence of hot-spot phenomenon in photovoltaic systems under PV partial shadowing. In an experimental campaign, the hot-spot phenomenon was revealed on a PV installation in Italy, caused by medium voltage overhead lines shadowing the PV cells. Starting from these practice case studies, at the SolarTech laboratory of Politecnico di Milano, the conditions for hot-spot phenomenon occurrence due to the overhead lines shading the PV cells were reproduced. Two experimental campaigns were carried out to investigate the current-voltage and power-voltage characteristics, and the energy production. In each experimental campaign, the built shadowing structure was considered fixed, and different shadowing conditions were created based on the natural displacement of the sun. Still, for occurring the hot-spot phenomenon during the laboratory tests, more PV modules must be connected in parallel.

Keywords: photovoltaic, hot-spot, laboratory tests, thermal imaging

1. Introduction

In case of normal operating conditions (no shading), the PV cell transforms the incident sun radiation into electrical energy. In case of partial cell shading, the PV current is reduced function of the cell's shading. As the PV cells are series connected within the modules, the cells affected by partial shading modifies their current-voltage characteristics, and conditions for their operation as electric load can occur. Under partial shading, the cell electrically operates as load, and the power is transformed into heat causing the increase of temperature. This cell temperature increase can cause its damaging or can melt the weldings, a phenomenon known as hot-spot. The hot-spot phenomenon can lead to the irreversible damage of the cell and a reduction of module power performances.

The in-depth analysis of the most common defects of PV modules was carried out in [1]. The results of electrical measurements and infrared imagery of the real practice PV modules reported the appearance of discoloration, cracking, snail tracks, soiling, busbar corrosion, encapsulant delamination, and hot-spots.

Experimental measurements and simulations were carried out on four

¹ Researcher, Department of Energy, Politecnico di Milano, Italy, alberto.dolara@polimi.it

² Associate Prof., Department of Power Systems, University POLITEHNICA of Bucharest, Romania, cristian.lazaroiu@upb.ro

³ Prof., Department of Energy, Politecnico di Milano, Italy, sonia.leva@polimi.it

single cell modules for analyzing the actual temperature inside the module in the vicinity of hot-spots in [2]. Thermocouples embedded in the cells, close to the hot-spots, measured the temperature inside the module, while an infrared camera was used to measure the temperature at cell's surface. Simulation results demonstrated that temperature of hot-spots located close to the PV module's edge have higher temperatures than the ones located in the module.

Ref. [3] presented four cases of hot-spots causes in real PV system, i.e. unwashed large bird droppings, dirt fixed at PV panel edges. Experiments were carried out with different shading percentages of a solar cell. Thermo-graphic analysis was conducted in each case, revealing a temperature difference between shaded and non-shaded cells of approximately 19 °C. Ref. [4] presents the procedure methodology to carry out quality checks of in-field PV systems connected to the grid. The thermal imaging was proved to be a baseline method to identify faulted modules with hot-spots caused by damaged cells.

The influence of partial shading on the number of maximum power points was studied through simulations in [5], considering variations of the ambient parameters under shading occurrences. The obtained results were validated through experiments for establishing if the operating MPP of the PV system is a local or global MPP [6].

A hot-spot phenomenon on a PV cell was revealed with a thermal camera under partial shading of this cell, the temperature exceeding 40 °C [7]. Electroluminescence and thermal imaging was used to highlight the hot-spot effect occurrence, determined by reduced manufactured contact, over the aluminum bus-bars of two cells within a multi-crystalline silicon PV module [8].

Ref. [9] proposes and experimentally validates a model to predict the hot-spot temperatures in a PV module with 60 multi-crystalline silicon cells under shading conditions, in a climate controlled chamber.

This paper experimentally analyzes the occurrence of hot-spot phenomenon in photovoltaic systems determined by partial shadowing of the PV cells. A hot-spot phenomenon was recorded in a field photovoltaic installation located in the east part of Italy. The hot-spot phenomenon was induced by the overhead medium voltage lines with a path crossing the PV modules field. The conditions for reproducing the shadowing occurrence at this field case study were implemented at the SolarTech laboratory of Politecnico di Milano, Italy. Two experimental campaigns were carried out: the first one investigated the current-voltage and power-voltage characteristics, and the second campaign investigated the energy production. In each experimental campaign, the built shadowing structure was considered fixed, and different shadowing conditions were created based on the natural displacement of the sun.

2. Field case study

In a PV system located in the east part of Italy, the hot-spot phenomenon determined by the overhead medium voltage lines shadowing the PV cells was recorded. The visual inspection and the analysis of the thermal images reveal the overheating of the modules shadowed by the overhead line, as illustrated in Fig. 1. The obtained field test results are reported in Table 1, and also shown in Fig. 1b.

Table 1

Recorded cell parameters on 26/04/2015@13:44:40

	Temperature [°C]	Emissivity degree		Reflected temperature [°C]
Most cold point 1	31.4	0.94		20
Most cold point 2	30.7	0.94		20
Most warm point 1	41.4	0.94		20

Fig. 2 shows the visual inspection and the analysis of thermal images on April 26th, at time instant 13:45:00. The obtained field test results are reported in Table 2, and also shown in Fig. 2b.

Table 2

Recorded cell parameters on 26/04/2015@13:45:00.

	Temperature [°C]	Emissivity degree	Reflected temperature [°C]
Most cold point 1 (CS1)	32.7	0.94	20
Most warm point 1 (HS1)	53.6	0.94	20

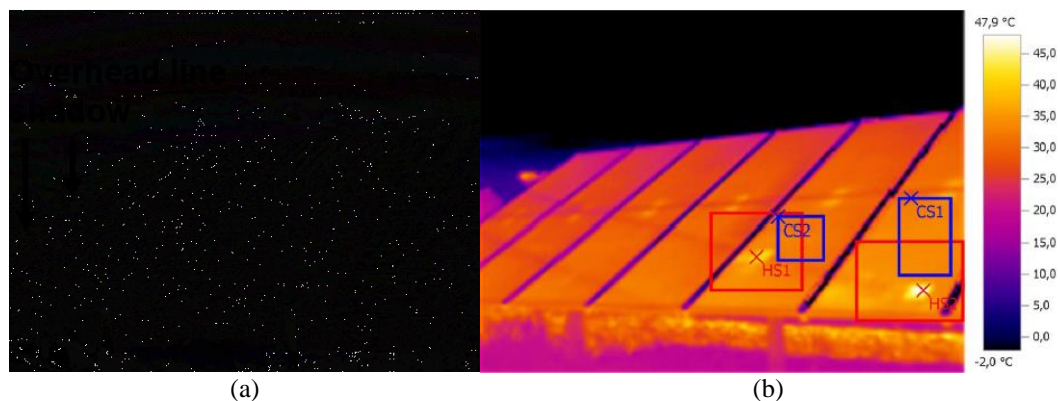

Fig. 1. Image of the field test case: a) visual inspection of PV system shadowed by overhead lines, b) thermal image of the PV systems highlighting the 4 points reported in Table 1.

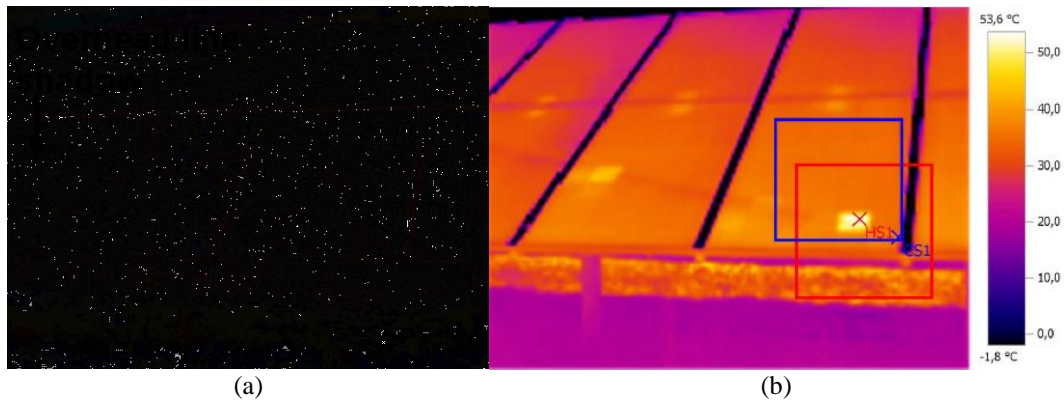

Fig. 2. Image of the field test case: a) visual inspection of PV system shadowed by overhead lines, b) thermal image of the PV systems highlighting the 4 points reported in Table 2.

3. Experimental setup and procedure of experiment

The experimental campaign was carried out at Solar Tech Lab of Politecnico di Milano, Italy. The PV panels of the Solar Tech Lab are located as shown in Fig. 3. More information regarding the PV characteristics of Solar Tech Lab are presented in [10]. All modules are facing South, placed on a structure tilted at 30° and with an azimuth of 6° eastward.

For the experimental campaign, the structure supporting the cable of medium voltage overhead lines was built and illustrated in Fig. 4. The structure supporting the cable has 3 m height. The shadowing tests were performed on a poly-crystalline PV module with 60 cells, 3 bypass diodes, and peak power of 245 W.

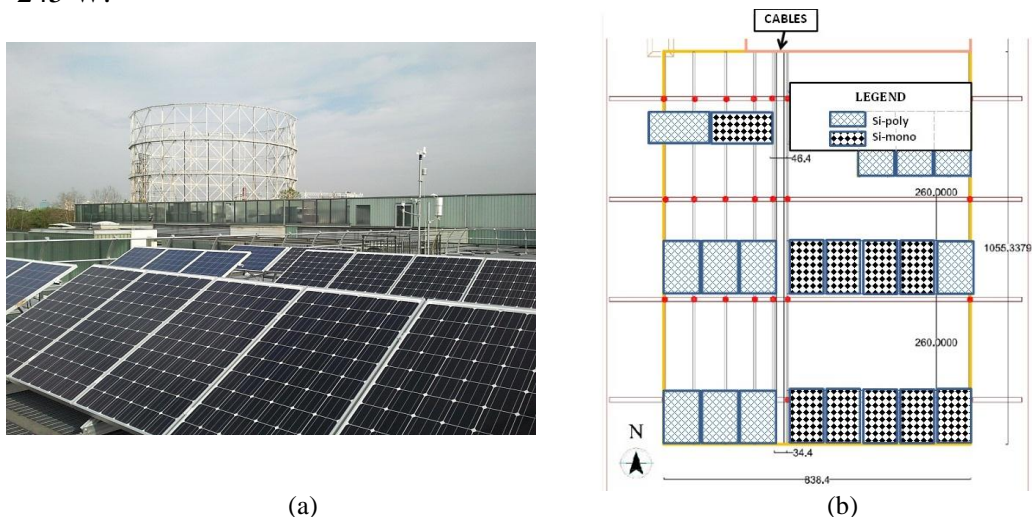

Fig. 3. PV modules installed at Solar Tech Lab, Politecnico di Milano



Fig. 4. Structure for simulating medium voltage overhead lines shading

The experimental tests recorded the current and voltage, and calculated the power voltage characteristics of the modules, in different operating conditions and in agreement with the requirements and procedures stipulated in [11-14] and [4]. The ambient conditions were monitored with a meteorological station equipped with solar radiation, temperature humidity and wind speed/direction sensors. The possibility to measure ambient temperature and wind conditions is not necessary for the performed analysis within this work. The main characteristics of solar radiation measuring equipment are reported in [10].

For obtaining the voltage-current characteristic of a PV module, the pairs of current and voltage values at module's terminals are required to be measured. This is carried out varying the voltage from 0 to open-circuit value, and the current from 0 to short-circuit value. The I - V characteristic of a PV module varies with irradiation and cell temperature [15-17]. For the field measuring campaign, the irradiation has the highest variability function of environmental conditions variation, like presence of clouds and wind. Thus, the measurements must be performed as fast as possible; hence, the PV module is connected to an automatic system consisting of SCADA (system control and data acquisition) and variable load.

The measurements were performed using the system in Fig. 5. The operating principle of the measurement instrument is illustrated through the block diagram shown in Fig. 5b, Fig. 5c and Fig. 5d show the measuring equipment components. Detailed presentation of the measurement procedure is given in [10].

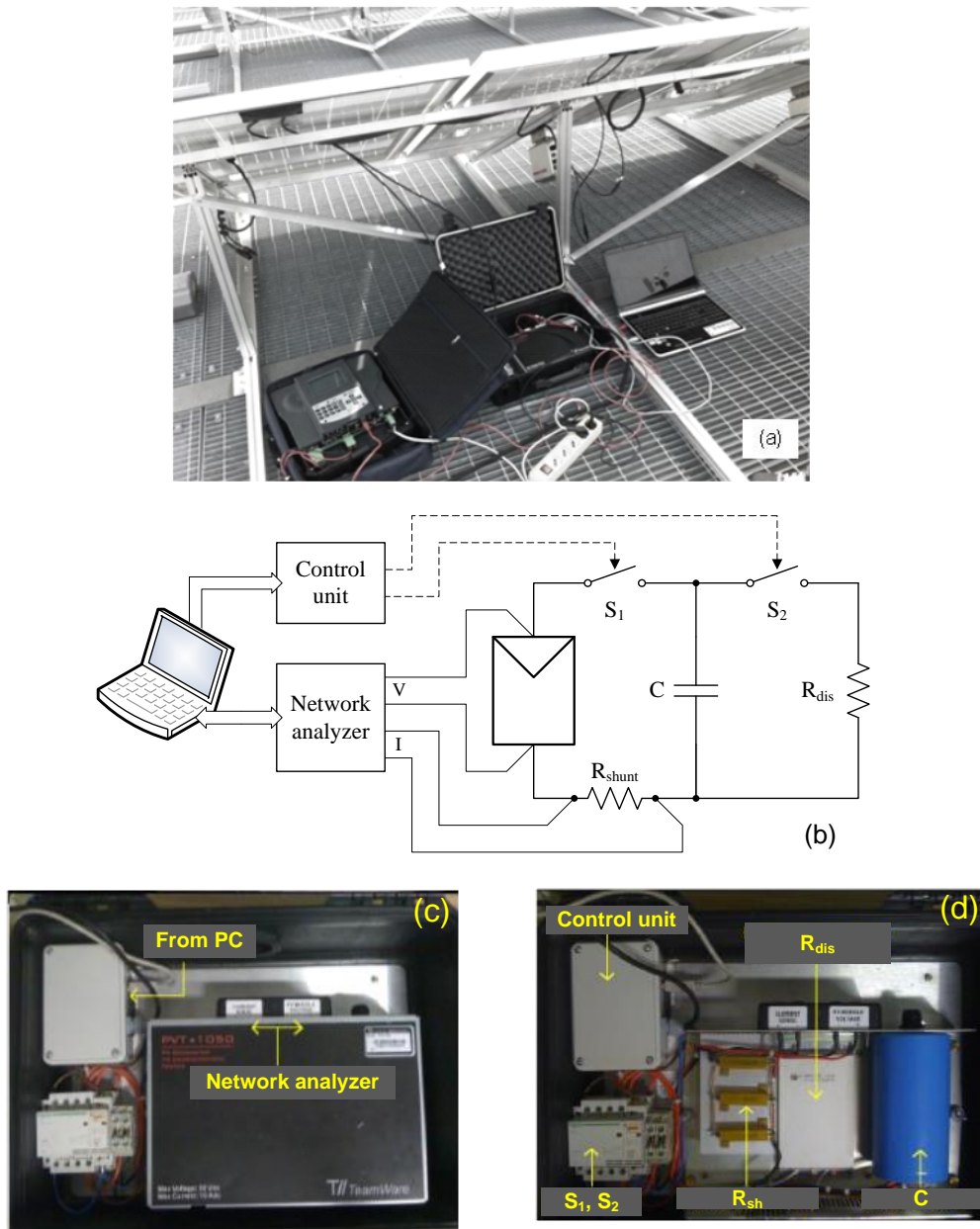

Fig. 5. Measurement equipments recording the PV characteristics: (a) field test measurements; (b) operating principle; (c), (d) components.

4. Experimental tests

Two typologies of experimental tests were performed, respectively:

- power tests: for recording the P - V (and I - V) characteristic of the PV module under partial shadowing;
- energy tests: for recording the voltage, current, and power of the PV module during the period of partial shadowing application.

4.1. Power experimental tests

The I - V measurements were performed every 5 minutes. For reducing the measuring error, each test corresponds to 10 measurements with the PV module under shadowing; the last measurement (the 11th one) is performed without shadowing such that to obtain the I - V reference characteristic of the module in case of temperature and irradiation conditions as for the previous measurements. The experiments were performed using a software for data acquisition; the PV module was disconnected from its inverter, but connected to the I - V measuring instrumentation. The flowchart of the measurement system is illustrated in Fig. 6.

The software for importing and elaborating the I - V characteristics measured during the tests require as input data:

- the power measurements conducted using the TeamWare instruments;
- the temperature recorded using the infrared camera Fluke Ti25;
- global irradiation during the test recorded by the meteorological station.

Using the graphic interface, the I - V and P - V characteristics are obtained as previously described. The shadow position during the monitoring campaign was registered through photos (as shown in Fig. 7a). During each measurement, the temperature of the PV module was measured using the Fluke Ti25 infrared camera (as illustrated in Fig. 7b). In addition, the global irradiation on the PV surface was measured through the sensors of the meteorological station.

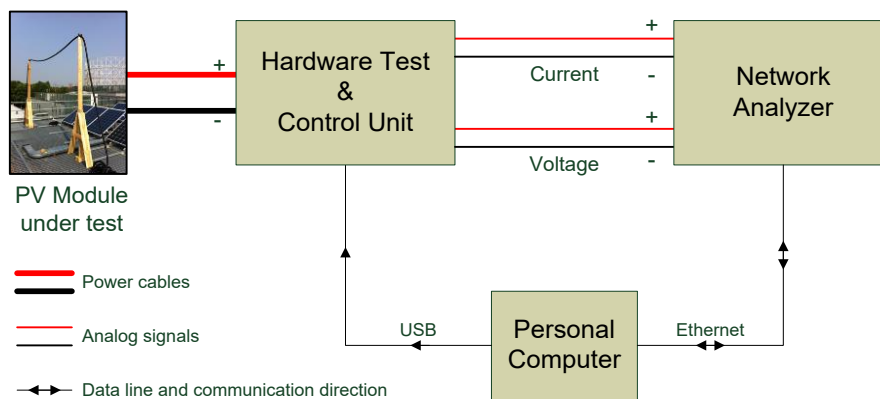

Fig. 6. Flowchart of the measuring system

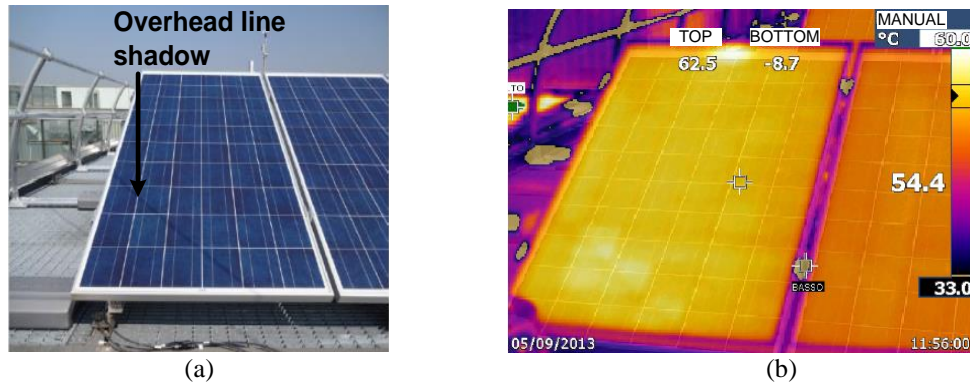

Fig. 7. Shadow position during the experimental campaign (a), and thermal image of the same PV module (b)

4.1.1. Results and discussion

For each measuring test conducted every 5 minutes on clear-sky conditions, the 10 measurements were averaged delivering the I - V and P - V characteristics and the results were compared with the 11th measurement conducted in no-shading condition. The obtained results are reported in Table 3.

Fig. 8a) illustrates the reference and measured I - V characteristic of the analyzed PV module at time instant 12.15. In Fig. 8b), the P - V characteristics at the same time instant are shown. In addition, the irradiation and module's temperature are reported.

4.2. Energy experimental results

The energy experimental tests were carried out considering the MV overhead lines shadowing structure, and PV module connected at its inverter for the normal operation. The recorded data were acquired using the monitoring software of the inverter. The data were elaborated in Matlab.

Table 3

Recorded data of the PV module.

Time instant	I_{MPP} shadow	V_{MPP} shadow	P_{MPP} shadow	I_{MPP} measured	V_{MPP} measured	P_{MPP} measured
@11.00	5.97	26.22	156.61	6.07	26.03	157.94
@11.20	6.48	25.79	167.30	6.49	25.90	167.95
@11.50	6.96	25.57	177.95	6.92	25.78	178.45
@11.55	6.90	25.67	177.28	6.92	25.46	176.33
@12.15	7.17	25.52	182.97	7.155	25.51	188.55
@12.40	7.33	25.66	187.99	7.19	25.51	186.03

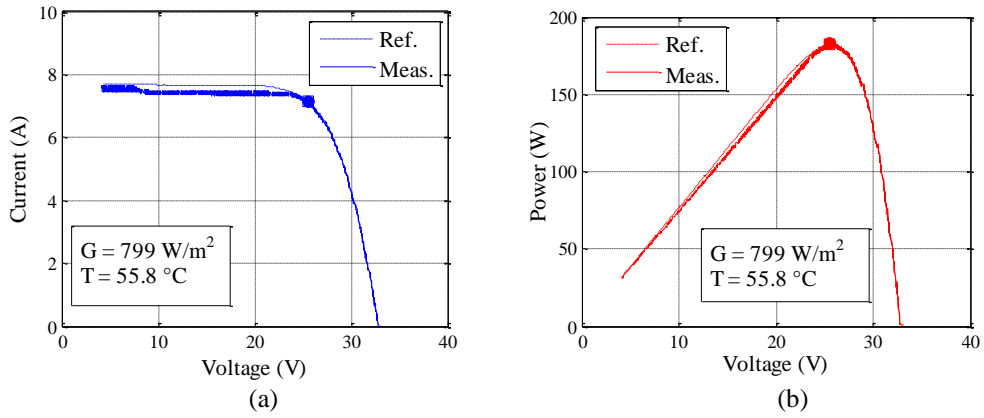

Fig. 8. Reference and measured PV characteristics @12.15 during the experimental campaign: (a) $I-V$, and (b) $P-V$

The energy tests compares the PV module production, under partial shading, with the production of modules not affected by shading. The graphs comparing for the same time interval the input power, voltage, and current of the analyzed PV module are illustrated in Fig. 9. Fig. 10 illustrates the thermal analysis performed with the infrared camera during the experimental tests.

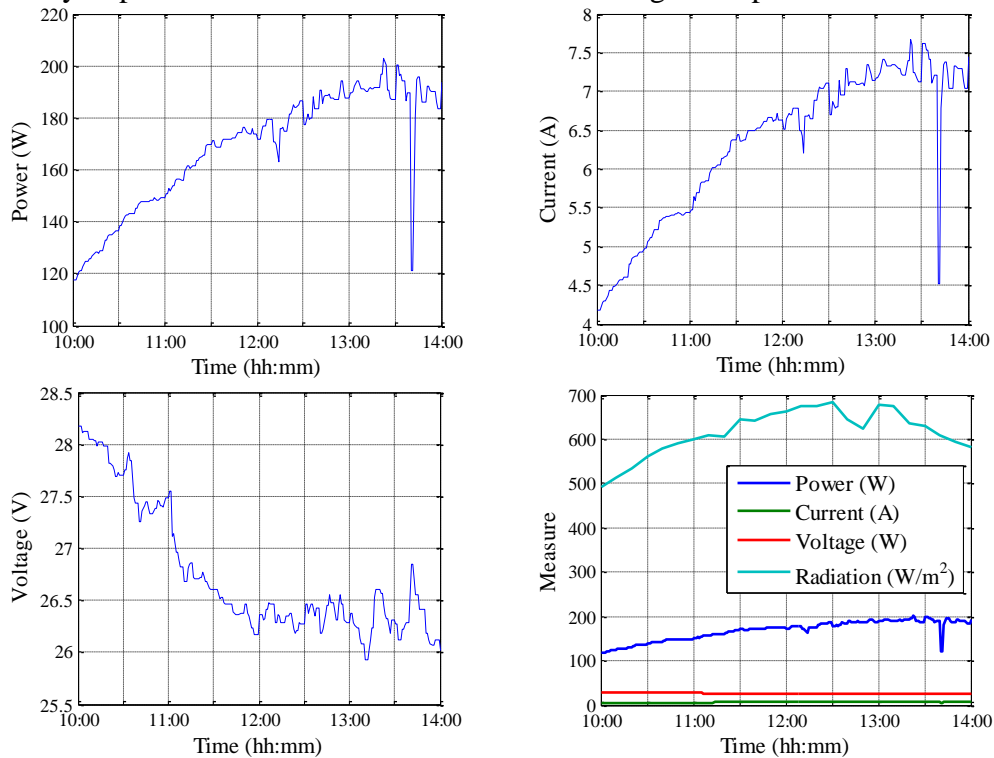

Fig. 9. Recorded input power, voltage, current and comparison of the monitored measures of the analyzed PV module

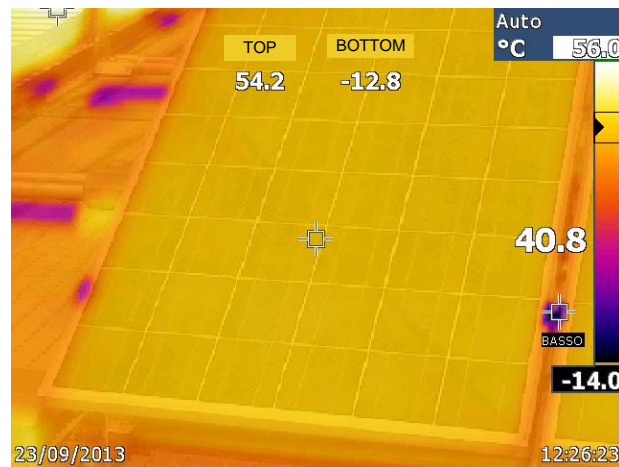

Fig. 10. Thermal analysis

The experimental results reveal that an important decrease of power is not observed. The shadowed cells continue to operate as generators. The power trend is similar to the other panels without shading.

5. Conclusions

The experimental analysis conducted within the SolarTechLab demonstrated the conditions for hot-spot phenomenon occurring during the normal operation of the PV modules with overhead power system cables with a path over the PV field.

The test results reveal a reduction of MPP for the shading module compared with the MPP of PV module without shading, for the same temperature but with uniform irradiation. During the experimental tests, a temperature increase was registered within the period when the cells are shaded. In addition, time instants occurred when the shaded cells are operating as load. Still, as these time instants were short, the over-temperature was small.

The results of energy tests did not reveal a significant reduction of generated energy, within the same observation period, of the PV modules with shading compared with the ones without shading. In the first stage, the experimental tests were conducted on a PV module directly connected to an inverter. In the second stage, 4 modules connected in parallel were investigated under overhead cable shading. One module was 14% shaded and the operating conditions, where at MPP the PV cell operated as load, were revealed. Still, for occurring the hot-spot phenomenon during the laboratory tests, more PV modules must be connected in parallel. The configuration with more PV modules in parallel reports, at reduced scale, the configuration of the PV system installed in the east part of Italy. At this location, more PV arrays are connected in parallel

and the electric layout of the investigated PV system leads to hot-spot phenomenon occurrence.

Further developments of the conducted analysis focus on various connection configurations of the PV modules and the validation, with thermal models developed for PV modules, of the temperature reached by the cells affected by the hot-spot phenomenon.

REFERENCES

- [1]. *S. Djordjevic, D. Parlevliet, P. Jennings*, “Detectable faults on recently installed solar modules in Western Australia”, in *Renewable Energy*, **vol. 67**, July 2014, pp. 215-221
- [2]. *H.J. Solheim, H.G. Fjær, E.A. Sørheim, S.E. Foss*, “Measurement and simulation of hot spots in solar cells”, in *Energy Procedia*, **vol. 38**, 2013, pp. 183-189
- [3]. *J. Solorzano, M.A. Egido*, “Hot-spot mitigation in PV arrays with distributed MPPT (DMPPT)”, in *Solar Energy*, **vol. 101**, March 2014, pp. 131-137
- [4]. *J.V. Muñoz, G. Nofuentes, J. Aguilera, M. Fuentes, P.G. Vidal*, “Procedure to carry out quality checks in photovoltaic grid-connected systems: Six cases of study”, in *Applied Energy*, **vol. 88**, no. 8, August 2011, pp. 2863-2870
- [5]. *A. Mäki, S. Valkealahti*, “Differentiation of multiple maximum power points of partially shaded photovoltaic power generators”, in *Renewable Energy*, **vol. 71**, November 2014, pp. 89-99
- [6]. *J. Qi, Y. Zhang, Y. Chen*, “Modeling and maximum power point tracking (MPPT) method for PV array under partial shade conditions”, in *Renewable Energy*, **vol. 66**, June 2014, pp. 337-345
- [7]. *A. Zegaouia, P. Petita, M.Ailleriea, J.P. Sawickia, J.P. Charlesa*, “Experimental Validation of Photovoltaic Direct and Reverse Mode Model. Influence of Partial Shading”, in *Energy Procedia*, **vol. 18**, 2012, pp. 1247-1253
- [8]. *J.L. Crozier, E.E. van Dyk, F.J. Vorster*, “Characterization of cell mismatch in a multi-crystalline silicon photovoltaic module”, in *Proceedings of the 4th South African Conference on Photonic Materials (SACPM 2011)*, *Physica B: Condensed Matter*, **vol. 407**, no. 10, 15 May 2012, pp. 1578-1581
- [9]. *I. Geisemeyer, F. Fertig, W. Warta, S. Rein, M.C. Schubert*, “Prediction of silicon PV module temperature for hot spots and worst case partial shading situations using spatially resolved lock-in thermography”, in *Solar Energy Materials and Solar Cells*, **vol. 120**, part A, January 2014, pp. 259-269
- [10]. *A. Dolara, G.C. Lazaroiu, S. Leva, G. Manzolini*, “Experimental investigation of partial shading scenarios on PV (photovoltaic) modules”, in *Energy*, **vol. 55**, June 2013, pp. 466-475
- [11]. *R. Moreto, E. Lorenzo, L. Narvarte*, “Experimental observations on hot-spots and derived acceptance/rejection criteria”, in *Solar Energy*, **vol. 118**, Aug 2015, pp. 28-40
- [12]. IEC 60904-1 “Photovoltaic devices. Part 1: measurements of photovoltaic current-voltage characteristics”, 1st ed., Geneve, International Electrotechnical Commission IEC-60904-1, 2006.
- [13]. IEC 60891, “Photovoltaic devices. Procedures for temperature and irradiance corrections to measured I-V characteristics”, 1st ed., Geneve, International Electrotechnical Commission IEC 60891, 2010.
- [14]. IEC 62446, “Grid connected photovoltaic systems-minimum requirements for system documentation, commissioning test and inspection”, 1st ed., Geneve, International

- Electrotechnical Commission IEC 62446, 2009
- [15]. *A.C. Vasko, A. Vijn, V.G. Karpov*, “Hot spots spontaneously emerging in thin film photovoltaics”, in *Solar Energy*, **vol. 108**, Oct 2014, pp. 264-273
 - [16]. *M. Brenna, A. Dolara, F. Foadelli, L. Gafaro, S. Leva, M. Longo*, “Solar energy exploitation for charging vehicles”, in *UPB Scientific Bulletin, Series C: Electrical Engineering*, **vol. 77**, 2015, pp. 277-284
 - [17]. *A. Dolara, G.C. Lazaroiu, S. Leva, G. Manzolini, L. Votta*, “Snail Trails and Cell Micro-Cracks impact on PV module maximum power and energy production”, in *IEEE Journal of Photovoltaics*, **vol. 6**, 2016, pp. 1269-1277