

POD curves for non-maximizable ultrasonic responses: Statistical derivation and application to solid freight axles

Michele Carboni and Stefano Cantini

Citation: [AIP Conference Proceedings](#) **1706**, 200011 (2016); doi: 10.1063/1.4940655

View online: <http://dx.doi.org/10.1063/1.4940655>

View Table of Contents: <http://scitation.aip.org/content/aip/proceeding/aipcp/1706?ver=pdfcov>

Published by the [AIP Publishing](#)

Articles you may be interested in

[Reliability analysis of laser ultrasonics for train axle diagnostics based on model assisted POD curves](#)

AIP Conf. Proc. **1600**, 396 (2014); 10.1063/1.4879608

[Methods for planning a statistical POD study](#)

AIP Conf. Proc. **1511**, 1725 (2013); 10.1063/1.4789249

[THE APPLICATION OF PHASED ARRAY ULTRASONIC TECHNIQUES FOR INSPECTION OF RAILWAY AXLES FROM THEIR END FACE](#)

AIP Conf. Proc. **1335**, 1440 (2011); 10.1063/1.3592101

[STATISTICAL STUDY OF ECT DETECTION AROUND FASTENERS USING SIMULATION BASED POD CURVES](#)

AIP Conf. Proc. **1211**, 1903 (2010); 10.1063/1.3362332

[An Application of Reversible Entropic Dynamics on Curved Statistical Manifolds](#)

AIP Conf. Proc. **872**, 243 (2006); 10.1063/1.2423281

POD Curves for Non-Maximizable Ultrasonic Responses: Statistical Derivation and Application to Solid Freight Axles

Michele Carboni^{1, a)} and Stefano Cantini^{2, b)}

¹*Politecnico di Milano, Department of Mechanical Engineering, Via La Masa 1, I-20165 Milano, Italy*

²*Lucchini RS SpA, Via G. Paglia 45, I-24065 Lovere (BG), Italy*

^{a)}Corresponding author: michele.carboni@polimi.it

^{b)}s.cantini@lucchinirs.it

Abstract. The most relevant standards on ultrasonic testing, and an effective inspection practice, require the maximization of echo responses due to indications before their evaluation in terms of amplitude and size. This is achieved effectively pointing the acoustic axis of the sound beam to the indication, in a way to get back the maximum possible sound energy. Considering some operative cases, however, such a response maximization is not always feasible, mainly due to geometrical constraints impeding the inspection of the whole control area with a constant sensitivity. The traditional end inspection of solid railway axles by a rotating probe mounting conventional sensors falls back into this kind of inspections. In particular, inspection angles are fixed and the probe holder cannot move along the axle allowing response maximization of in-service damages located, for example, along the cylindrical body. It follows some control areas cannot be inspected using the maximum sound pressure. The present research shows how the derivation of “Probability of Detection” curves for non-maximizable ultrasonic responses cannot be carried out by the traditional statistical approach and a novel one, of the “Model-Assisted Probability of Detection” kind, is consequently proposed based on experiments and numerical simulations.

INTRODUCTION

The most relevant standards on ultrasonic non-destructive testing (UT) [1], and an effective inspection practice, require the maximization of echo responses reflected by indications. This allows obtaining an always-repeatable reference condition before carrying out the evaluation of indications in terms of amplitude and size. From a practical point of view [2], the maximization of echo responses reflected by indications is obtained positioning the acoustic axis of the sound beam so to point at the location of maximum reflection of the indication itself. However, in some operative cases, maximization is not achievable, mainly due to geometrical constraints not allowing the inspection of the whole control area with constant sensitivity. It is, then, necessary to keep into account of this situation during both the preparation of inspection procedures and the definition of the most suitable sample blocks for the given application.

The present scenario of European freight railway applications shows a tendency towards new maintenance procedures for in-service solid axles, with the aim to define higher safety levels and, at the same time, to optimize the total cycle life cost of the wheel-set. Among traditional inspection techniques, the association of private operators of freight wagons has developed its own guidelines, which require inspections of axles based on many angled probes applied to the external surface of the axles themselves [3]. Such a methodology is characterized by two drawbacks: partial removal of coatings and the need for disassembling of bearings and axle boxes. Particularly, the development of a new generation of permanent coatings [4] makes their partial removal inappropriate to apply UT inspections.

It is worth remembering in-service or maintenance inspections aim to detect possible damages, and consequent crack propagation to failure, due to typical in-service phenomena, such as corrosion-fatigue and ballast impacts, according to a “Damage Tolerant” [5]-[6] approach: inspections must, then, be particularly effective for those axle sections where stresses and probability of damage are higher. With these premises, since the ‘70s thanks to the work of the Italian Railways [7], the rotating probe, applied to axle ends (Fig. 1a), has been adopted for the inspection of

solid axles in Italy. According to Lucchini RS SpA's inspecting procedure [8], such a probe is configured with different angled transducers (Fig. 1b) able to inspect the critical regions of axles (geometrical transitions and press-fit seats). The traditional limits of this technique are mainly related to the surface conditions of axle ends: in particular, identification markings must not be so deep to influence sensitivity and the presence of the three threaded holes (located at 120° from each other) for the application of the taps of the axle boxes shadow longitudinal portions of the axle. Moreover, the rotating probe does not allow maximizing the echo response of indications because no longitudinal movement are permitted along the axle, and this fact puts this probe in the special cases discussed above.

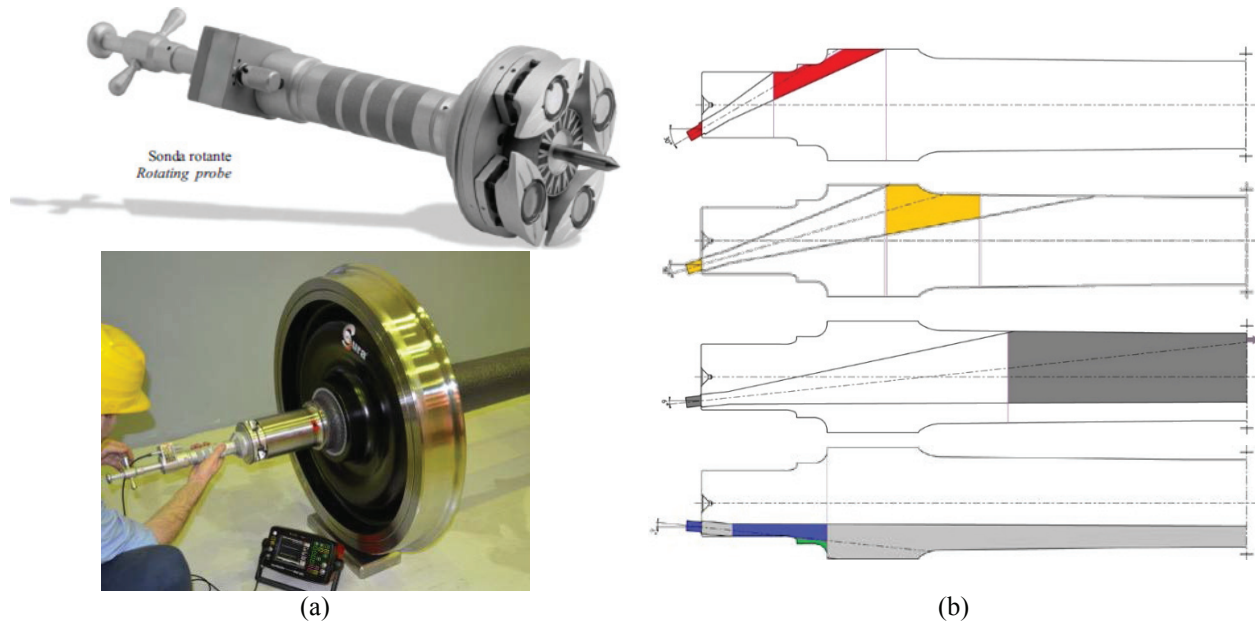

FIGURE 1. Rotating probe for ultrasonic inspection of solid axles.

Structural integrity of in-service axles is then guaranteed, along with other characterizing factors of the Damage Tolerant approach [5]-[6], by a reliable derivation of the “Probability of Detection” (POD) curves [9]-[11] of the rotating probe. Traditionally, such POD values are expressed and drawn as a function of a characteristic linear dimension of defects (depth, length, diameter, ...), but, on the other hand, they are also influenced by many other physical and operative factors. For this reason, very rarely the POD curve for a given NDT procedure can be applied to other ones, even if similar.

In the present research, it is shown, assuming as an applicative case a solid railway axle (diameter of the body equal to 173 mm, diameter of wheel press-fit seat equal to 200 mm) made of EA1N steel grade, that the derivation of POD curves for non-maximizable UT responses cannot be carried out by the classical statistical method. Consequently, a novel one is presented of the “Model-Assisted Probability of Detection” (MAPOD) kind [12]-[14], based on experiments and numerical simulations. Numerical simulations were carried out by the dedicated software CIVAn^{de} 11.0 [15].

A NOVEL SAMPLE BLOCK FOR THE ROTATING PROBE

For brevity and clarity, the present paper describes just the convergent angled probe at 6° (4 MHz, diameter 20 mm, longitudinal wave) dedicated to the inspection of the central cylindrical body of the axle (third case from top in Fig. 1b). The traditional sample block for the calibration of this particular transducer [8] considers just one artificial defect located at the intersection between the acoustic axis of the sound beam and the external surface of the axle (Fig. 2a). This is a non-conservative configuration, for the evaluation of the reliability of the NDT procedure based just on experimental data, because the response of any other defect with the same size, but not located at the acoustic axis, is lower or, at least, equal in terms of amplitude.

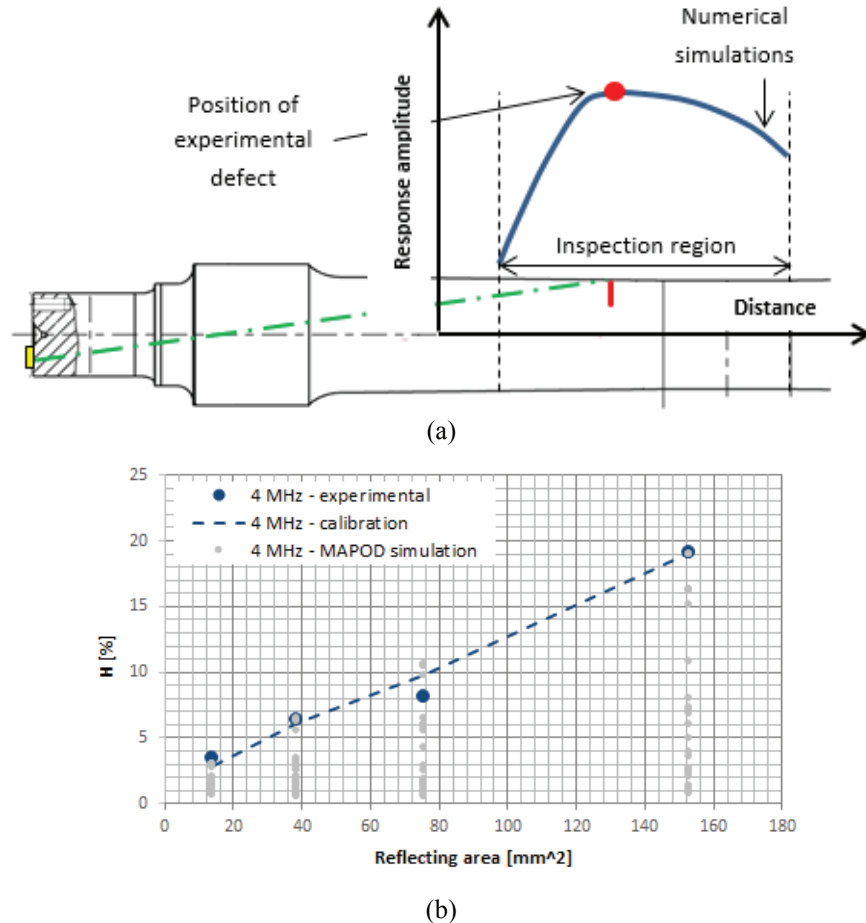

FIGURE 2. Traditional calibration of the rotating probe and its problems.

Figure 2b shows the comparison between experimental data and the numerical responses simulated, by MAPOD approach for defects randomly located along the central cylindrical body of the axle, previously obtained in [16]: as expected, numerical data show an extended standard deviation and experimental ones correspond to the upper bound for defects with the same reflecting area.

A novel sample block was, then, designed and realized (Fig. 3a) with the aim to study the effect of different defect locations along the axle axis. In particular, a series of concave defects, with dimensions equal to $2 \times 10 \text{ mm}^2$, was realized by EDM and distributed according to a helicoid curve along the axle axis. The sample axle was then inspected by the 6° convergent transducer according to Lucchini RS's procedure [8] (Fig. 3b). All defect responses were recorded, also outside the inspection region of the considered transducer, in terms of gain needed to take the amplitude at the 80% of the screen. The novel sample block allowed to highlight the 6° convergent transducer is ineffective, for the considered defect size, at the closer part of the inspection region. On the other hand, it allowed detecting defects much farer (until 1500 mm) than the inspection region limit. These observations seem to suggest the possibility of optimizing this particular transducer.

“MODEL-ASSISTED PROBABILITY OF DETECTION” ANALYSIS

With the aim to analyse more deeply the problem due to the non-maximization of responses and achieve the optimization of the considered transducer, a numerical campaign was carried out to characterize in more detail the responses of defects located along the body of the axle.

The first step consisted in the experimental evaluation of the structural attenuation coefficient of EA1N steel grade according to [2]. Such a parameter is very important for the numerical set-up, especially considering the 6° convergent

transducer generates a sound beam running long distances into the material. The structural attenuation coefficient resulted to be equal to $\alpha=9$ dB/m at 4 MHz.

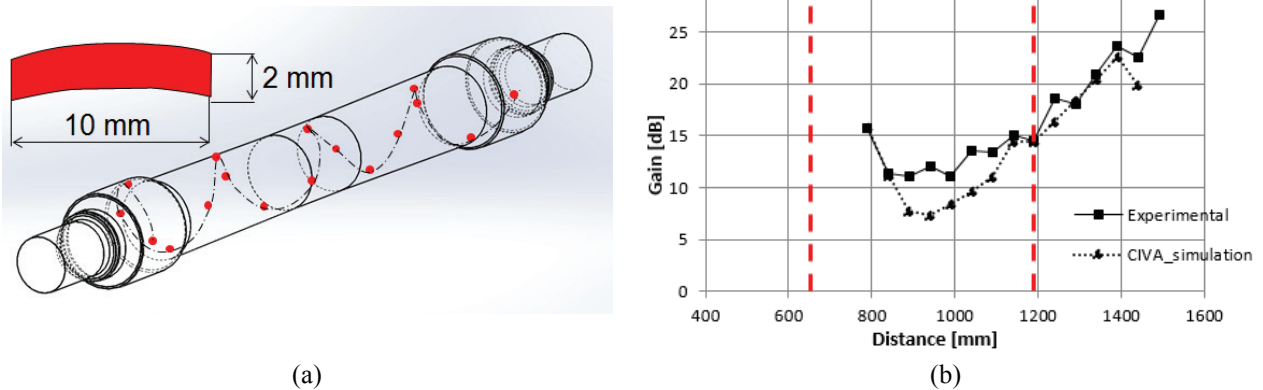

FIGURE 3. Ultrasonic inspection of the novel sample block (6° convergent transducer).

Then, a model of the novel sample block was built and its inspection simulated, by the dedicated software CIVA^{ndc} 11.0 [15], in order to compare the obtained results to experimental measurements and to validate the model itself (Fig. 3b). As can be seen, numerical responses show a good similarity with experimental data, allowing stating that, indeed, the built numerical model is well representative of the inspection of the novel sample block.

The following step, to obtain a first approximation suggestion, consisted in analysis of the sound pressure field acting on the external surface of the axle body without defects. Particularly, the research of the optimized value of the refraction angle was carried out considering discrete variations (6° , 7° e 8°) starting from the present value used on the rotating probe. Comparing the obtained trends (Fig. 4), the optimized refraction angle seems to be 8° convergent. This angle allows obtaining both the highest pressure value and to increase the response from the left bound of the inspection region, where the other angles indicate a high needed gain.

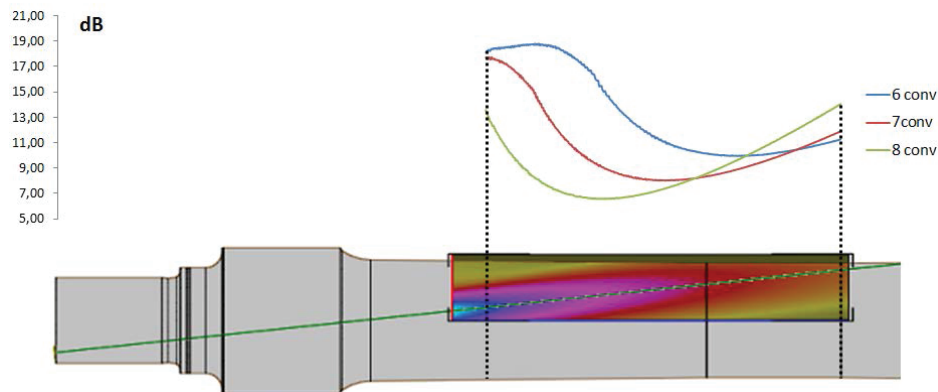

FIGURE 4. Analysis of the sound pressure field for different refraction angles.

Starting from these first approximation conclusions, the second phase of the optimization took advantage of a more refined and accurate approach based on the analysis of “signal response” data and the generation of MAPOD curves for the inspection procedure. The analysis was carried out for all the three refraction angles identified by the sound pressure field study. Figure 5 shows, in terms of reflecting area of defects [17], the simulated results obtained for the 6° convergent transducer and their comparison with experimental data acquired by the inspection of the novel sample block. It is possible to note the standard deviation of numerical results is comparable to the experimental one, so validating again the numerical model.

It is, however, necessary to highlight two main points. The first one is that the traditional methodology to derive MAPOD curves requires a linear trend of data, but this does not seem to occur in this case. The second one deals again

with the traditional methodology because it requires, also, the standard deviation of UT responses can be described by a Normal distribution, but this hypothesis seems not to be respected, as well. Before analysing data, it is then needed to deepen these points.

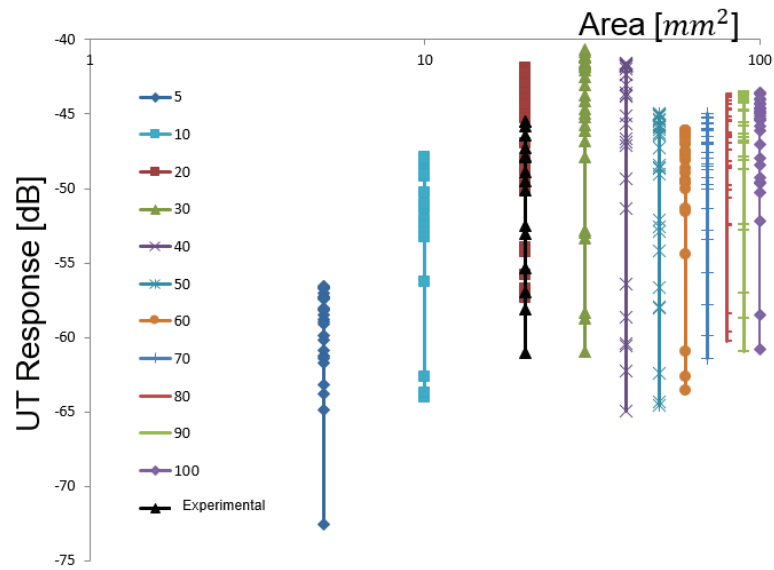

FIGURE 5. MAPOD analysis for the 6° convergent transducer.

ANALYSIS OF NON-MAXIMIZABLE ULTRASONIC RESPONSES

Considering the statistical distribution of the numerical data obtained for each reflecting area, the occurrences histogram can be built (Fig. 6a) allowing observing values are not symmetrical with respect to the mean, but there is a strong accumulation at the maximum value. This is directly due to the impossibility to maximize UT responses in this case. It remains the hypothesis of a Normal distribution centred on the mean value is not verified for the analysed samples.

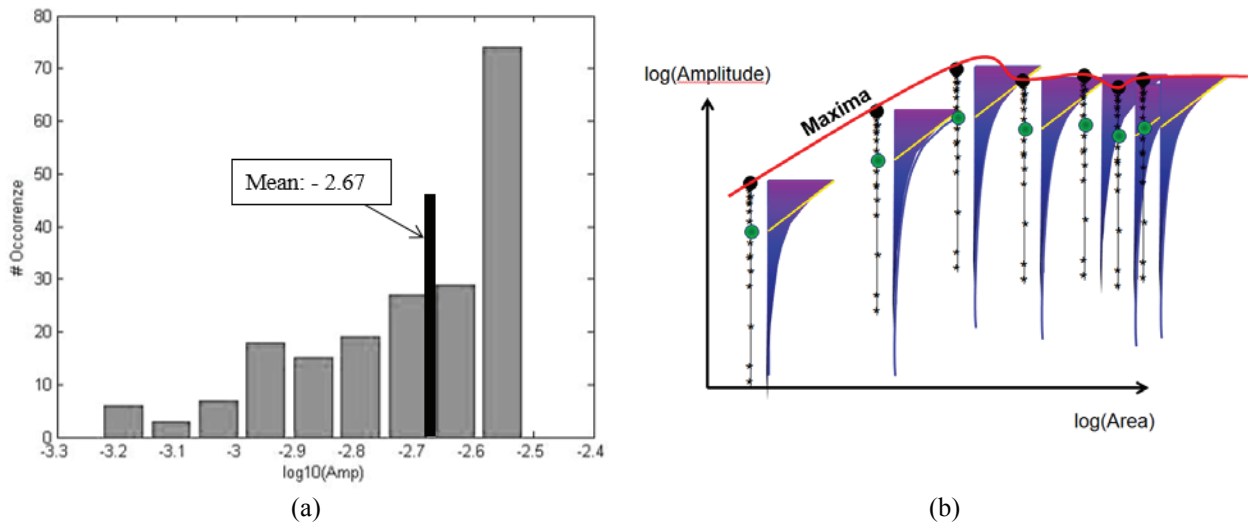

FIGURE 6. Statistical analysis of rotating probe UT responses.

It was, then, necessary to introduce a new statistical distribution able to represent this data trend: the positive bi-parametric exponential one, characterized by the following probability density function $f(t)$ and cumulative probability $F(t)$:

$$\begin{cases} f(t) = \lambda \cdot \exp[\lambda(t - t_s)] & \text{if } t < t_s \\ f(t) = 0 & \text{if } t > t_s \end{cases} \quad (1)$$

$$\begin{cases} F(t) = \exp[\lambda(t - t_s)] & \text{if } t < t_s \\ F(t) = 1 & \text{if } t > t_s \end{cases} \quad (2)$$

The application of the Maximum Likelihood method to the estimation of parameters λ and t_s is, in this case, particularly straightforward because t_s represents the maximum value of the obtained responses and is straight derivable from data (Fig. 6b). The Maximum Likelihood method must then estimate the λ parameter only.

Considering instead the trend of data with the reflecting area of defects, Figure 7 reports numerical results for different defect sizes and three different inclination angles between the defect plane and the external surface of the axle. A relationship, then, exists between the refraction angle, defect size and defect inclination angle able to guarantee the linearity of the curve in Figure 5, according to the traditional approach, only if the defect is perpendicular to the acoustic axis of the sound beam (6° in the case of Figure 7). To solve this problem, the trend of the maximum values of ultrasonic responses was approximated by interpolation using cubic splines curves (Fig. 6b). Such a kind of piecewise curve, being defined so to guarantee continuity of the first derivative at nodes, allows following accurately the trend of data.

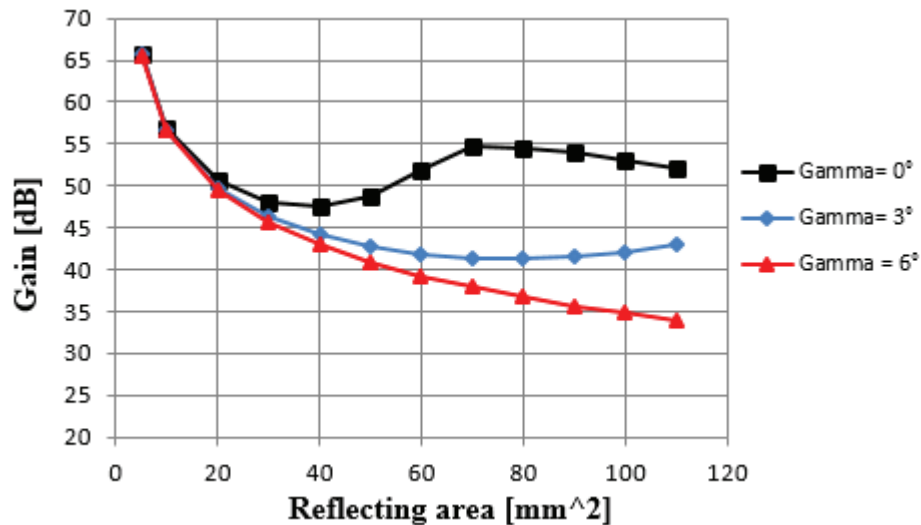

FIGURE 7. Trend of ultrasonic responses with the reflecting area of defects.

PROBABILITY OF DETECTION CURVE FOR THE ROTATING PROBE

Defined the mathematical tools to supersede the differences between the traditional approach and the case of non-maximizable ultrasonic responses, it is now possible to derive the MAPOD curve and to optimize the 6° convergent transducer.

Figure 8 shows the MAPOD curves obtained by numerical simulations using the mathematical tools described in the previous section. The 8° convergent transducer allows maximizing the probability of detection and then it defines the optimum refraction angle for the inspection of the central cylindrical body of the axle. The increase of probability of detection, especially for small defects, provides a general improvement of UT responses within the inspection

region. It is also possible to conclude the first approximation predictions of the optimum refraction angle, based on the sound pressure field, are confirmed by the more accurate MAPOD approach.

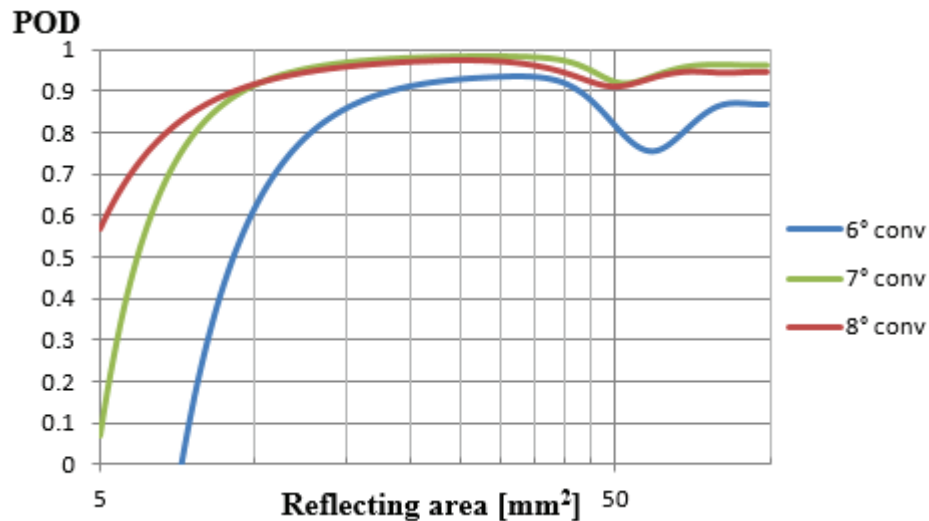

FIGURE 8. MAPOD curves for 6°, 7° and 8° convergent transducers.

CONCLUDING REMARKS

Thanks to MAPOD curves and their comparison for different refraction angles, it was possible to define the optimum one for the convergent transducer devoted to the inspection of the central cylindrical body of solid axles. The fact that the inspection of solid axles by the rotating probe applied to their ends falls back into the category where ultrasonic responses cannot be maximized required the development of specific mathematical tools such as the exponential bi-parametric statistical distribution and the dissertation about the trend of responses as a function of defect size and inclination. The latter is common to all tests and presents an initial linear region for the smallest defects followed by an oscillatory trend for the largest ones.

The computational time required by MAPOD simulations was about 275 hours. A posteriori, it is possible to highlight that, to the only aim to optimize the angle of the rotating probe, the sound pressure analysis could have been enough. In that case, the computational time was about 5 hours. On the other hand, the sound pressure analysis alone provides a partial vision of the involved physical phenomena because it does not allow predicting the trend of responses as a function of defect size and inclination.

ACKNOWLEDGEMENTS

The authors sincerely thank Mr. L. Girlanda for the active help given to the present research and Prof. S. Beretta (Politecnico di Milano) for the useful discussion.

REFERENCES

1. EN ISO 16810, Non-destructive testing – Ultrasonic testing – General principles, 2014.
2. J. Kraütramer and H. Kraütramer, *Ultrasonic Testing of Materials*, 4th edition (Springer-Verlag, Berlin, 1990).
3. VPI, VPI 04 – Maintenance of freight wagons – Wheel-sets, 2nd edition, 1st modification, valid since 01/08/2008.
4. S. Cervello and D. Sala, “LURSAK: Development of Innovative anti impact coating return from experience”, in *17th International Wheelset Congress 2013*, Kiev (Ukraine).
5. S. Cantini and S. Beretta (Editors), *Structural reliability assessment of railway axles*, LRS-Techno Series 4, 2011.
6. A.F. Grandt Jr., *Fundamentals of structural integrity*, (John Wiley & Sons Inc., Hoboken, 2003).
7. G. Pettinato, *La Metallurgia Italiana* **8**, 367-374 (1971).

8. F. Benzoni, S. Cantini, L. Tonelli, Istruzione Tecnica QUA IT 142 Rev.1. 2013, Lucchini RS S.p.A., Lovere (BG), Italy.
9. G.A. Georgiou, *Probability of Detection (POD) curves: derivation, applications and limitations*, Research Report 454, HSE Books, Health and Safety, Executive, UK, 2006.
10. ASM, ASM Handbook – Vol. 17: Non-destructive evaluation and quality control, 1997.
11. MIL-HDBK-1823A, Nondestructive evaluation system reliability assessment, Department of Defence of the USA, 2009.
12. <http://www.cnde.iastate.edu/MAPOD/index.htm>.
13. R. B. Thompson, *Materials Evaluation* **69**(7), 861-865 (2001).
14. J.S. Knopp, J.C. Aldrin, E. Lindgren and C. Annis, “Investigation of a model-assisted approach to probability of detection evaluation”, AFRL-ML-WP-TP-2006-494 Report, AIR FORCE RESEARCH LABORATORY, 2006.
15. CEDRAT, CIVA^{nde} 11.0 User’s Manual, 2014.
16. M. Carboni, S. Cantini and C. Gilardoni, “Validation of the Rotating UT Probe for In-Service Inspections of Freight Solid Axles by Means of the MAPOD Approach”, *5th European-American Workshop on Reliability of NDE*, 1-8, 2013.
17. M. Carboni, *Insight* **54**, 208-216 (2012).