

H₂ Production from Bioethanol and its Use in Fuel-Cells

Ilenia Rossetti^{*a}, Josè Lasso^a, Matteo Compagnoni^a, Giorgia De Guido^b, Laura Pellegrini^b

^aDip. Chimica, Università degli Studi di Milano, INSTM Unit Milano-Università and CNR-ISTM, via Golgi 19, 20133 Milano, Italy

^bDipartimento di Chimica, Materiali e Ingegneria Chimica "G. Natta", Politecnico di Milano, Piazza Leonardo da Vinci 32, I-20133 Milano, Italy
 ilenia.rossetti@unimi.it

Bioethanol was considered as raw material for hydrogen production by steam reforming, coupled with a proton exchange membrane fuel cell for heat and power cogeneration (5 kW_{electrical} + 5 kW_{thermal}). The water/ethanol feeding ratio and the ethanol purity were considered for process optimisation. An increase of the water/ethanol ratio improved H₂ yield at the expenses of higher heat input to the reformer and lower electrical output. However, the presence of a high enthalpy exhaust stream increased the available thermal output, with a consequent increase of the thermal and overall efficiency of the plant. Finally, the bioethanol purification step, which is energy- and cost-intensive, has been taken into account, searching for an optimisation of the bioethanol purification strategy for the overall process intensification.

1. Introduction

H₂ production from bioethanol, coupled with its use in fuel cells, has raised considerable attention in recent years for the co-generation of heat and power (CHP) from renewable sources (Kirillov et al., 2008; Ni et al., 2007; Díaz Alvarado and Gracia, 2010). Additionally, second generation bioethanol is becoming available (www.biochemtex.com), opening questions about the real economic sustainability of its use in CHP systems. Process optimisation is needed to assess their potential economic sustainability.

The operational variables chosen for process simulation are taken from an actually existing unit GH2-BE-5000 (Helbio SA Hydrogen and Energy Production Systems), capable of delivering 5 kW_{electrical} + 5 kW_{thermal} output, which is being tested in the frame of a demonstrative project c/o the Dept. of Chemistry of Università degli Studi di Milano, Italy (Rossetti et al., 2010; Rossetti et al., 2012a). Among the different variables considered, the water/ethanol ratio was found particularly relevant to optimise process yield and its economic sustainability. Therefore, this work first presents the results of the investigation of the effect of bioethanol purity on the catalytic activity for H₂ production. After evaluating the feasibility of its use under several reaction conditions, the simulation of a possible CHP system has been carried out, coupled with the optimisation of its purification from the fermentation broth.

2. Models and methods

2.1 General layout of the CHP unit

The tested CHP system (Rossetti et al., 2010; Rossetti et al., 2012a) is composed of:

a) a multi-tubular steam reforming (SRE) reactor filled with a steam reforming catalyst. The heat of reaction is provided on the outer wall of the tubes by catalytic combustion of part of the reactant (bioethanol with a purity higher than 96 vol%), as suggested for example by De Souza et al. (2013). Heat valorisation of the spent reformate constituting the anodic exhaust, with maximum fuel utilisation in the fuel cell being 75 %, has been included in process simulation, whereas the tested prototype does not have a post-combustion section. A pre-reformer is used to achieve the thermal decomposition of bioethanol.

b) Two water-gas shift (WGS) reactors working at high and low temperature ensure proper H₂ yield and preliminary reformat purification from CO (< 1 vol%).

c) Selective methanation (METH) is added, since the selected fuel cells operate at low temperature and, hence, they are poorly tolerant to CO. Two methanators, connected in series, are present in the tested unit, the second reactor being a guard to prevent accidental CO feeding to the fuel cell. CO concentration in the reformat has been always found to be lower than 10 ppm.

d) A stack of proton exchange membrane fuel cell (PEMFC) has been tested, using the previously produced and purified reformat. Efficiency has been calculated as the ratio between the net electrical and thermal energy output and the energy input. The latter was determined from the amount of inlet ethanol and its lower heating value (LHV = 1234.8 kJ mol⁻¹).

The CHP unit GH2-BE-5000 is fed with 142 g/min of a solution with a water/ethanol (H₂O/C₂H₅OH) ratio of 5.7 mol/mol. Heat supply to the reformer is ensured by the catalytic combustion of 96 vol% C₂H₅OH. The reformat is fed to a PEMFC operating at 80 °C and 1.8 bar. The heat exchange network is partially integrated, e.g. heat recovery is accomplished by using the hot reformer outlet to preheat the pre-reformer and supply heat to the evaporation unit, to increase the overall process efficiency. Heat integration has been optimised during simulation, together with the heat valorisation of the anodic exhaust, which is not included in the experimental setup. Different tools have been used, such as Aspen Plus®, Matlab™, Athena Visual Studio™.

2.2 Catalytic activity testing with bioethanol of different purity

Two different bioethanol solutions have been experimentally tested, with ethanol concentration ca. 50 and 90 vol% (BE50 and BE90), corresponding to different purification steps. They were kindly supplied by Biochemtex (Mossi&Ghisolfi group) and used to feed a micropilot plant for SRE catalysts screening, for a comparison with absolute ethanol (Aldrich, 99.9 vol%). The tested catalyst, 10 wt% Ni/ZrO₂ + 9 wt% CaO, was prepared by flame pyrolysis and resulted to be particularly promising after an extensive preliminary screening (Rossetti et al., 2012b; Rossetti et al., 2014; Nichele et al., 2014). Activity testing was carried out at atmospheric pressure, variable temperature (300-750 °C) with 3:1 mol/mol water/ethanol feeding ratio, GHSV = 2500 h⁻¹ (referred to the ethanol + water gaseous mixture). Details on the activity testing apparatus and the analytical/data elaboration tools are described elsewhere (Rossetti et al., 2012b).

2.3 Optimisation of the bioethanol purification strategy

Due to the rising interest in bioethanol production, attention is increasingly paid to the optimization of its purification processes due to the huge impact (50-80 %) on bioethanol production costs. These processes typically comprise two sub-processes for concentrations up to ethanol mole fractions lower than that of the azeotrope and for further dehydration to high ethanol purity levels. The optimisation of the concentration section has resulted in a division into columns working at different pressures, so that the reboiler of the low-pressure column can be thermally coupled with the condenser of the high-pressure one (Lynn and Hanson, 1986). As for the dehydration step, different separation concepts have been proposed: a) the heterogeneous azeotropic distillation with a third component, capable of forming a heterogeneous azeotrope with water (e.g., benzene, toluene, n-pentane or cyclohexane); b) the extractive distillation using a third component to modify the water/ethanol relative volatility (e.g., glycols); c) the distillation at different pressures, taking advantage of the variation in composition of the azeotrope with pressure (less used) (Black, 1980; Lee and Pahl, 1985; Lynn and Hanson, 1986). Indeed, the mole fraction of ethanol, which characterizes the azeotrope, increases with decreasing pressure until disappearing at pressures lower than 11.5 kPa. Therefore, dehydration can be achieved under vacuum in the absence of an azeotrope or by using two columns, connected in series, with increasing pressure (Pressure-Swing Distillation), with a third component to facilitate the separation. Among the possible entrainers for the extractive distillation, ethylene glycol most significantly modifies the relative volatility between water and ethanol (Lee and Pahl, 1985). All these separation schemes allow to produce anhydrous ethanol which is widely used in the chemical industry as a solvent or as a raw material or intermediate in several syntheses. However, the ethanol purity for the SRE process investigated in this work is much lower and a new process scheme has been considered for concentration, as explained in the following.

3. Results and discussion

3.1 Effect of bioethanol concentration on activity testing and on CHP performance

The water/ethanol feeding ratio turned out to be a very critical parameter during activity testing for hydrogen production. From a catalytic performance point of view, the increase of the water/ethanol molar ratio increased H₂ yield due to a beneficial effect on the thermodynamics of the WGS reaction. Furthermore, an overstoichiometric water/ethanol feeding ratio (stoichiometric value = 3 mol/mol) improved the resistance of the steam reforming catalyst towards deactivation by coking, which is critical when operating at relatively low

temperature ($T < 600$ °C). On the other hand, a decrease of the steam reforming operating temperature from the commonly used range 750-900 °C is also envisaged for process intensification, to limit the heat input for this endothermic reaction. Active and stable catalysts have been developed allowing to completely convert bioethanol and possibly formed by-products (e.g., acetaldehyde, ethylene and partly methane) already at 500 °C (Rossetti et al., 2012b; Rossetti et al., 2014). An increase of the water feeding amount helped improving the resistance towards coke deposition at even lower temperature, *i.e.* down to 400 °C.

Table 1: Catalyst activity testing with different ethanol purity

Feed	H ₂ O/ethanol = 3 (mol/mol)								
	Absolute C ₂ H ₅ OH/H ₂ O			BE90/H ₂ O			BE50/H ₂ O		
Temperature (°C)	500	400	300	500	400	300	500	400	300
Ethanol conversion (%)	100 ± 0	100 ± 0	34 ± 4	100 ± 0	100 ± 0	29 ± 3	100 ± 0	100 ± 0	22 ± 1
H ₂ productivity (mol/min/kg _{cat})	1.1 ± 0.1	0.75 ± 0.01	0 ± 0	1.13 ± 0.07	0.80 ± 0.02	0 ± 0	1.08 ± 0.09	0.80 ± 0.04	0 ± 0
Sel. CH ₄ (%)	19 ± 2	37 ± 3	10 ± 1	20 ± 3	34 ± 2	11.2 ± 0.09	16 ± 2	26 ± 2	3 ± 5
Sel. CH ₃ CHO (%)	0 ± 0	0 ± 0	59 ± 9	0 ± 0	0 ± 0	60 ± 4	0 ± 0	0 ± 0	49 ± 3
Sel. CH ₂ CH ₂ (%)	0 ± 0	0 ± 0	0 ± 0	0 ± 0	0 ± 0	0 ± 0	0 ± 0	0 ± 0	0 ± 0

Experimental results for the steam reforming of ethanol were collected with the water/ethanol ratio set at the stoichiometric value, *i.e.* under the most critical operating conditions. The catalytic performance was always satisfactory at high temperatures (*i.e.*, above 600 °C): full ethanol conversion was achieved, with H₂, CO and CO₂ as the only products and the CO/CO₂ ratio depending on the WGS equilibrium. Under these conditions, H₂ productivity attested on 1.30 mol/min/kg_{cat} (data not reported in this work). In order to explore unconventional low-temperature experimental conditions, which would allow significant energy saving, the catalytic activity was tested also at lower temperatures and the results are reported in Table 1. Full ethanol conversion was maintained even at 400 °C. H₂ productivity progressively decreased with temperature due to the increasing concentration of unreacted methane. At 300 °C some ethanol conversion was still observed, but the C-C bond cleavage activity of the catalyst was insufficient, so that the main product was acetaldehyde. When testing bioethanol on the selected catalyst under the same reaction conditions, the same results were achieved irrespectively of the purification degree of the feed stream. Indeed, the use of bioethanol containing 50 or 90 vol% ethanol, obtained after different purification stages of lignocellulosic bioethanol, led to very similar hydrogen productivity with respect to absolute ethanol.

This important result demonstrates the feasibility of hydrogen production from bioethanol characterised by lighter purification strategies with respect to the raw material designated for gasoline blending, where much higher purity (>99 vol%) is required. Indeed, a bioethanol concentration of 25 mol% or lower is needed for steam reforming. Such concentration is interesting for purification cost saving, but it may include possible impurities in the feed, which will be further investigated by means of detailed feed characterisation and catalyst durability tests. At the moment, the following conclusion can be drawn: on a properly selected catalyst, it is possible to safely use 90 and 50 vol% bioethanol for H₂ production at T higher than 600 °C and even at 500 °C, with lower hydrogen productivity due to incomplete reforming of methane. Consequently, some process optimisation and cost analysis have been performed to better assess the most convenient bioethanol purity from the point of view of water/ethanol feeding ratio.

3.2 SRE process simulation and optimisation of the water/ethanol feeding ratio

The CHP unit GH2-BE-5000 has been used as basis for process simulation. A significant modification of the process layout has been introduced in the simulation with respect to the demonstrative equipment: it consists in the split of the reformat to feed the fuel cell and the catalytic combustor to heat up the reformer, once the system is in steady-state conditions. This allows the use of diluted ethanol to feed the system (Figure 1). The power output and the efficiency of the system are shown in Figure 2. When more diluted ethanol is fed to the plant, a higher amount of reformat is used as fuel to heat up the SRE reactor to evaporate the higher amount of water, so the reformat fraction used in the fuel cell is lower, with consequent decrease of the electrical output and efficiency. By contrast, the thermal output increases due to a higher amount of heat made available by excess steam, which may be recovered downstream. Therefore, the electrical efficiency decreases from 0.32 when feeding 25 mol% C₂H₅OH, to 0.21 for ca. 7 mol% C₂H₅OH, while the thermal efficiency increases from 0.40 to 0.65. As a consequence, the overall efficiency of the system increases from 0.72 to 0.86. The electrical efficiency here achieved was higher than what reported by Francesconi et al. (2007) for a similar

system with SRE heating provided by ethanol combustion. By contrast, Giunta et al. (2007) reported higher efficiency for a slightly different system, while co-generation from ethanol-methane mixtures was proposed by Arpornwichanop et al. (2014). It is possible to conclude that the use of diluted bioethanol is technically feasible and this may open the way to a decrease of the purification costs of this biofuel with respect to its use in internal combustion engines, for which it should be heavily dehydrated.

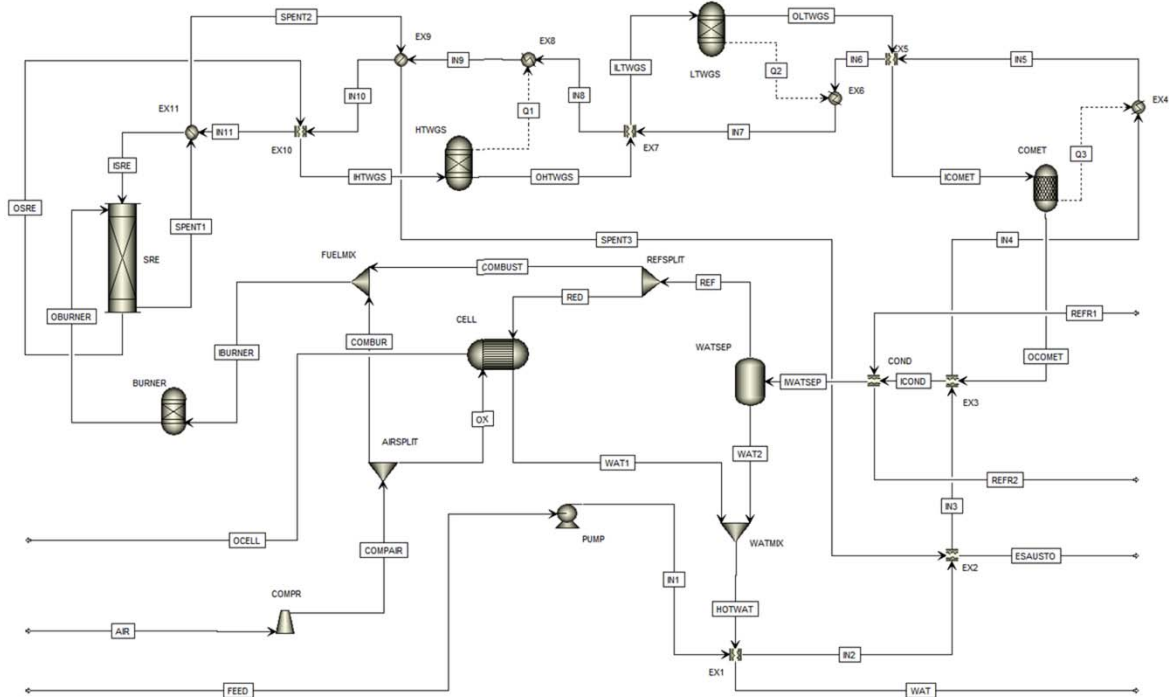

Figure 1: Process scheme for reformat production, purification and use in a PEM-FC system

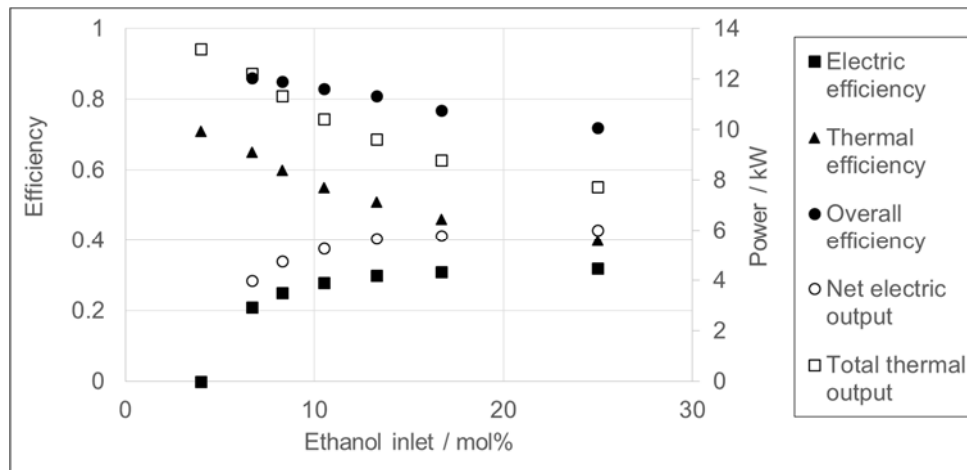

Figure 2: Electrical and thermal power output (empty symbols) as a result of simulations with variable water/ethanol feeding ratio. Plant efficiency (full symbols) is calculated with respect to the lower heating value of the ethanol fed to the system

3.3 Optimisation of the bioethanol purification strategy

Since the ethanol purity for the SRE process investigated in this work is low, the concentration of the ethanol-water mixture could be theoretically reached in a single stage of vaporization (flash drum). The second column of Table 2 summarizes the thermal energy required to obtain the mixtures with the same composition as those in Figure 2, starting from a 10 wt% fermentation broth and using Aspen Plus® (AspenTech, 2012) process simulator, with the Predictive-Soave-Redlich-Kwong (PSRK) (Holderbaum and Gmehling, 1991) thermodynamic package. It was proved in previous works (Pellegrini et al., 2007; Pellegrini et al., 2012; Pellegrini et al., 2013; Langè et al., 2013) that the best agreement with experimental equilibrium data can be attained by using *ad-hoc* calculated adaptive parameters whose introduction, however, leads to negligible

improvements in this case, since the considered range of compositions is sufficiently far from the azeotrope (Pellegrini et al., 2010). As the ethanol mole fraction in the mixture to be sent to the CHP unit decreases, the required energy increases due to the presence of larger amounts of water to be vaporized and the recovery of ethanol in the vapour stream increases up to a maximum of 93.6 %, as shown in Table2. In order to get higher recovery of ethanol in the concentrated stream while limiting thermal energy requirements, a new process scheme is considered in this work, as shown in Figure3. The mixture containing 10 wt% ethanol (4.16 mol%) is split into two streams, one of which enters a distillation column which has 10 theoretical stages. The distillate product is then mixed with the non-concentrated fraction of the feed to give a stream whose composition has to be equal to that of the mixture to be fed to the CHP unit. The ethanol recovery in the distillate product has been set to 99.9 %, whereas the ethanol purity in the distillate has been chosen so that the reboiler duty is minimum: the optimum value has turned out to be 48 mol%, which corresponds to a split fraction for all the cases considered in this work as reported in Table 2, along with the values of the reboiler duty. The concentration process is less energy demanding with increasing dilution of the mixture to be fed to the CHP unit.

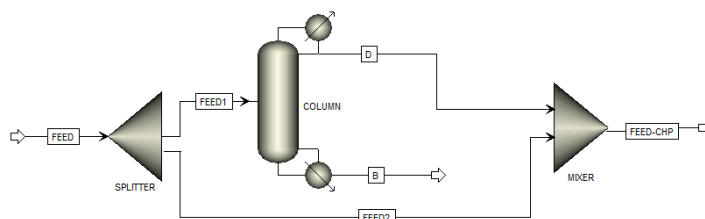

Figure 3: Scheme of the concentration section process for bioethanol purification (Aspen Plus®).

Table2: Duties and ethanol recovery for concentration in a flash drum, split fractions and reboiler duties for concentration as proposed in the scheme of Figure3

C ₂ H ₅ OH (mol%) in FEED-CHP	Flash Duty (kW)	C ₂ H ₅ OH		Reboiler Duty (kW)
		Recovery (%)	Split Fraction	
25.0	189	22.0	0.9127	399
16.7	325	61.2	0.8216	359
13.3	414	73.5	0.7531	329
10.5	525	82.5	0.6622	289
8.3	661	89.0	0.5479	239
6.7	820	93.6	0.4117	180

4. Conclusions

The results presented in this work allow to draw the following conclusions:

- 1) it is possible to use bioethanol of different purity levels to produce hydrogen through the steam reforming process, provided that an active and stable catalyst is used. The process can be safely carried out at temperature higher than 600 °C, by feeding water/ethanol in a 3 mol/mol ratio or higher to optimise hydrogen productivity. In the view of process intensification, it is possible to lower the reaction temperature down to 500 °C without depressing significantly hydrogen yield. Further investigation is in progress to assess the effect of possible impurities in the feed on catalyst life at different reaction temperatures.
- 2) Simulations of a CHP system show that the stoichiometric water/ethanol ratio allows to achieve the highest electric efficiency, but the use of higher ratios helps increasing the overall system efficiency (electrical + thermal) and is usually intended to prevent catalyst deactivation by coking.
- 3) The bioethanol purification has been carried out in a distillation column, which concentrates only a fraction of the fermentation broth. The thermal consumption of the reboiler has been estimated by process simulation using the PSRK thermodynamic model as implemented in Aspen Plus®. The impact of the concentration step on the energy consumption of the overall process is lower for lower ethanol mole fractions in the mixture to be fed to the CHP unit.

Acknowledgements

Biochemtex, Mossi&Ghisolfi Group, is kindly acknowledged for supplying samples of bioethanol. The authors

are indebted with Linea Energia S.p.A, Parco Tecnologico Padano, Provincia di Lodi and Università degli Studi di Milano for financial support.

References

- Arpornwichanop A., Suwanmanee U., Saebea D., Patcharaworachot Y., Authayanun S., 2014, Study on a Proton Exchange Membrane Fuel Cell System Fuelled by a Mixture of Bio-Ethanol and Methane, *Chemical Engineering Transactions*, 39, 1033-1038, DOI: 10.3303/CET1439173
- AspenTech, 2012, Aspen Plus®. AspenTech, Burlington, MA, United States.
- Black C., 1980, Distillation Modeling of Ethanol Recovery and Dehydration Processes For Ethanol and Gasohol, *Chemical Engineering Process* 76, 78-85.
- DeSouza M., Faria S.H.B., Zanini G.M., Moraes F.F., 2013, Production of Hydrogen for Fuel Cell: Microchannel Reactor Modelling for Combustion and Reform of Ethanol in Alternate Channels, *Chemical Engineering Transactions*, 32, 835-840, DOI: 10.3303/CET1332140
- Díaz Alvarado F., Gracia F., 2010, Steam reforming of ethanol for hydrogen production: Thermodynamic analysis including different carbon deposits representation, *Chem. Eng. J.* 165, 649-657.
- Francesconi J.A., Mussati M.C., Mato R.O., Aguirre P.A., 2007, Analysis of the energy efficiency of an integrated ethanol processor for PEM fuel cell systems, *J. Power Sources* 167, 151-161.
- Giunta P., Mosquera C., Amadeo N., Laborde M., 2007, Simulation of a hydrogen production and purification system for a PEM fuel-cell using bioethanol as raw material, *J. Power Sources* 164, 336-343.
- Holderbaum T., Gmehling J., 1991, PSRK: A Group Contribution Equation of State Based on UNIFAC, *Fluid Phase Equilibria* 70, 251-265.
- Kirillov V.A., Meshcheryakov V.D., Sobyenin V.A., Belyaev V.D., Amosov Yu.I., Kuzin N.A., Bobrin A.S., 2008, Bioethanol as a promising fuel for fuel cell power plants, *Theoretical Foundations of Chemical Engineering* 42, 1-11.
- Langè S., Pellegrini, L.A., Moioli S., Picutti B., Vergani P., 2013, Influence of gas impurities on thermodynamics of amine solutions. 2. Mercaptans, *Industrial & Engineering Chemistry Research* 52, 2025-2031.
- Lee F., Pahl R.H., 1985, Solvent Screening Study and Conceptual Extractive Distillation Process To Produce Anhydrous Ethanol from Fermentation Broth, *Ind. Eng. Chem. Process Des. Dev.* 24, 168-172.
- Lynn S., Hanson D.N., 1986, Multieffect Extractive Distillation for Separating Aqueous Azeotropes, *Ind. Eng. Chem. Process Des. Dev.* 25, 936-941.
- Ni M., Leung D.Y.C., Leung M.K.H., 2007, A review on reforming bio-ethanol for hydrogen production, *Int. J. Hydrogen Energy* 32, 3238-3247.
- Nichele V., Signoretto M., Pinna F., Menegazzo F., Rossetti I., Cruciani G., Cerrato G., Di Michele A., 2014, Increasing the resistance to coke of Ni/ZrO₂ catalysts in ethanol steam reforming reactions by CaO-doping, *Appl. Catal. B: Environ.* 150-151, 12-20.
- Pellegrini L.A., Gamba S., Bonomi S., Calemma V., 2007, Equilibrium constants for isomerization of n-paraffins, *Industrial & Engineering Chemistry Research* 46, 5446-5452.
- Pellegrini L.A., Gamba S., Moioli S., 2010, Using an adaptive parameter method for process simulation of non ideal systems, *Industrial & Engineering Chemistry Research* 49, 4923-4932.
- Pellegrini L.A., Langè S., Moioli S., Picutti B., Vergani P., 2013, Influence of gas impurities on thermodynamics of amine solutions. 1. Aromatics, *Industrial & Engineering Chemistry Research* 52, 2018-2024.
- Pellegrini L.A., Moioli S., Gamba S., Ceragioli P., 2012, Prediction of vapor-liquid equilibrium for reservoir mixtures with cubic equations of state: Binary interaction parameters for acidic gases, *Fluid Phase Equilibria* 326, 45-49.
- Rossetti I., Biffi C., Forni L., G.F. Tantardini, G. Faita, M. Raimondi, E. Vitto, D. Alberti, 2010, Proceedings of the "ASME 2010 Eight International Fuel Cell Science, Engineering and Technology Conference, Fuel Cell 2010" 2, 465-472.
- Rossetti I., Biffi C., Tantardini G.F., Raimondi M., Vitto E., Alberti D., 2012a, 5 kW_{el} + 5 kW_{th} PEM-FC generator from bioethanol: fuel processor and development of new reforming catalysts, *Int. J. Hydrogen Energy* 37, 8499-8504.
- Rossetti I., Biffi C., Bianchi C., Nichele V., Signoretto M., Menegazzo F., Finocchio E., Ramis G., Di Michele A., 2012b, Ni/SiO₂ and Ni/ZrO₂ catalysts for the steam reforming of bioethanol, *Appl. Catal. B: Environmental* 117-118, 384-396.
- Rossetti I., Lasso J., Finocchio E., Ramis G., Nichele V., Signoretto M., Di Michele A., 2014, Silica and Zirconia supported catalysts for the low-temperature ethanol steam reforming, *Appl. Catal. B: Environmental* 150-151, 257-267.
- <www.biochemtex.com/proesa>accessed 01.12.2014.