

Impact of IMPSA Wind Power Plant on Ninh Thuan - Binh Thuan Grid With Small Signal Stability Assessment

Kim Hung Le¹, Vinh Tinh Tran¹, Minh Quan Duong^{1,2}, Marco Mussetta², Manh Hung Duong³

¹University of Science and Technology – The University of Danang, Department of Electrical Engineering, Danang, Vietnam

²Politecnico di Milano, dipartimento di Energia, Milano, Italy

³II Power Transmission Company, Vietnam

Abstract

Voltage stability issue is a key problem which is attracting worldwide attention because it may lead to voltage collapse. This research presents an implementation of a Ninh thuan – Binh Thuan grid model in Power System Analysis Toolbox (PSAT) – free and open source software. A newly developed IMPSA wind turbine model is modeled and connected to Ninh Thuan – Binh Thuan power system. The impact of IMPSA Wind Power Plant on the Ninh Thuan - Binh Thuan grid is carried out and analyzed with small signal stability. In this paper, IMPSA wind turbine based on variable speed wind generators are considered. The article ends with a validation of the stable Ninh Thuan – Binh Thuan grid model generated by PSAT including new variable speed wind turbine model. This validation is done through eigenvalue analysis by applying small disturbances from wind speed variation.

Key Words: Stability, Wind turbine, Wind speed, Modeing, Power system analysis

1. Introduction

The development of the installed capacity of grid connected renewable energy source is continuously growing as a result of the environmental concerns in order to minimize the impact of conventional electricity generation [1]. Wind power is the world's fastest growing renewable source as shown in Figure 1. During last decade, the average annual growth rate of wind turbine installation is around 30 % [2]. As wind energy is fed into the power system, the stability of already existing grid is becoming important as wind farms should not defile the stability of the existing grid, if feasible, offer to enlarged system stability. Therefore, wind plants should behave responsibly. For example, the important point during last several years is the continued grid-connection of wind turbine at definite grid-voltage disturbance levels, to avoid voltage drops and sectional energy deficits when wind energy units are disconnected.

Wind power plants must provide the power quality required ensuring the reliability of the power system where it is connected to and to fulfill the clients connected to the same grid. It is very important to understand the sources of disturbances that affect the power quality [3 - 5].

depending on parameters belongs to turbines, generators, governors. They affect both small signal stability and transient stability. There are a number of studies that has been carried out recently for identifying required network reinforcement, reserve requirements and the impact of wind power on power system stability [6]. These studies are dealing with different problems related to wind plant, such as fluctuating nature of wind energy, location of wind generations, various generator technologies and control. The results are generally representing a super position of various wind power aspects and predict required grid reinforcements, reserve requirements, the impact on grid stability.

Reference [7] investigates the modeling and the transient stability analysis of the wind integrated IEEE 14 test bus system. The aim of the investigation is the enhancement of transient stability using central area controller in a wind integrated power system with storage. In [3, 8] a comparison is made among 3 main type of wind turbines such as constant speed wind turbine (CSWT), Doubly Fed Induction Generator (DFIG), Direct Drive Synchronous Generator (DDSG) and their steady and transient characteristics were analyzed and simulated, respectively. Nordic grid model implemented using Power System Analysis Toolbox it is also validated through time domain simulation by applying small and large disturbances in reference 9. This research proposes an improved model of the modified Nordic power system for power system stability analyses and studies. The improved model includes a newly developed hydro turbine and hydro governor model which is capable of representing the actual dynamic behavior of hydro units. Consequently, a suitable control can be used to limit the negative impact of oscillations and instability.

This research investigates small signal stability of IMPSA variable speed wind generators which is integrated to Ninh Thuan - Binh Thuan power system. Furthermore, this paper also introduces mathematical modeling of variable speed wind generator in section II. The IMPSA wind power plant connected to Ninh Thuan - Binh Thuan power system simulated using Power System Analyses Toolbox is shown in section III. The results are analyzed in section IV, concluded in part V.

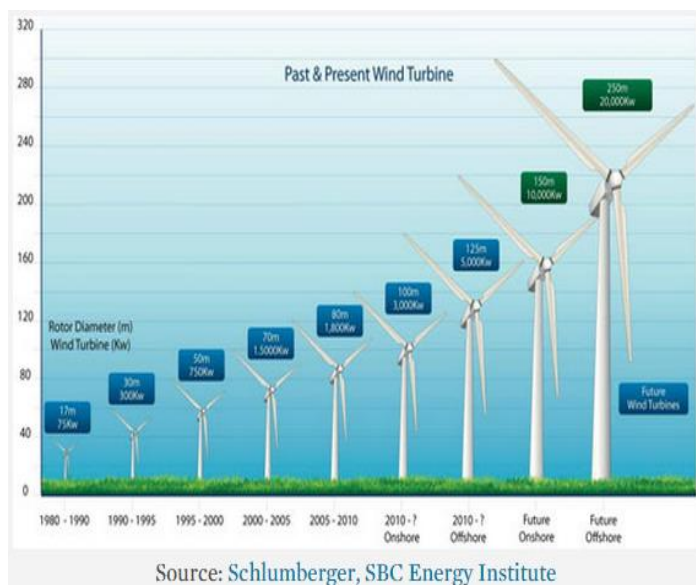

Figure 1. Growing wind turbine capacity

Integration of a wind power into grid arise issues like voltage stability, transient stability problem. Power system stability is

2. Small signal stability and modeling

In this part, small signal stability of the system has been analyzed. Small signal stability is defined as the ability of a power system to resum to its original stable state after beeing subjected to a small disturbance which leads to a small

incremental change in power system state variables. In other words, the system's response to a small disturbance in power system state is variable.

Power System Analyses Toolbox based Eigen value analysis has been done to determine small signal stability of the system. Here correlation between Eigen values and power system dynamics is discussed. For this, a liberalized model is developed to find out the resemblance between Eigen values, steady state matrix and time domain simulation. State space equation and output equation is given by

$$\dot{X}(t) = f(x, u, t) \quad (1)$$

$$y(t) = g(x, u, t) \quad (2)$$

where equation (1) has all state variables such as 'u' is the input variables, 't' is the time and 'y' is the output function. The linearization of Eqn. (1)-(2) will help to study the response to small variations.

In order to obtain this, polynomial equations are developed using Taylor's series formula where higher order terms are neglected. Linear combination of system is presented as

$$\dot{X} = Ax + Bu \quad (3)$$

$$y = Cx + Du \quad (4)$$

here A, B, C and D are obtained from the Jacobean matrix which contains partial derivative of the functions in terms of 'f' and 'g' respectively to the input variable 'u' and the state variable 'x'.

2.1. Wind Modeling

In this paper Weibull distribution wind speed model with nominal wind speed as 15m/s is used. Weibull distribution is represented in this case as shown in Figure 2.

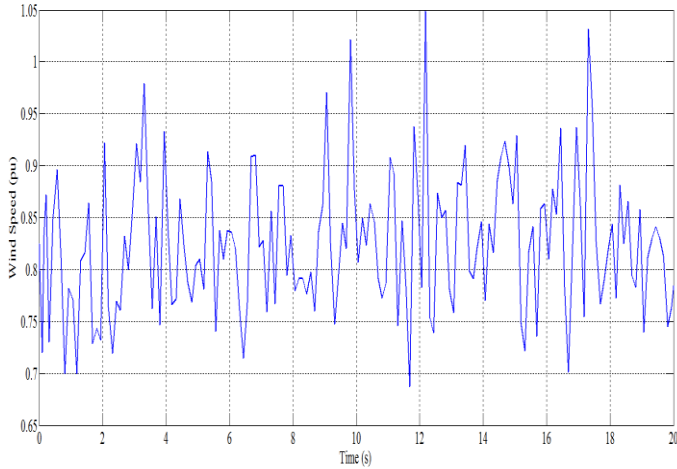

Figure 2. Weibull distribution wind speed

2.2. IMPSA variable speed wind turbine modeling

The structure of IMPSA variable speed wind generator is shown in Figure 3. The steady state electrical equations are assumed, the flux dynamics of stator and rotor are fast in comparison with grid dynamics and the generator decoupling from the grid can be done by the converter control mechanism. These assumptions lead to equations (5)-(8):

$$v_{ds} = -r_s i_{ds} + ((x_s + x_m) i_{qs} + x_m i_{qr}) \quad (5)$$

$$v_{qs} = -r_s i_{qs} - ((x_s + x_m) i_{ds} + x_m i_{dr}) \quad (6)$$

$$v_{dr} = -r_r i_{dr} + (1 - \omega_m) ((x_r + x_m) i_{qr} + x_m i_{qs}) \quad (7)$$

$$v_{qr} = -r_r i_{qr} - (1 - \omega_m) ((x_r + x_m) i_{dr} + x_m i_{ds}) \quad (8)$$

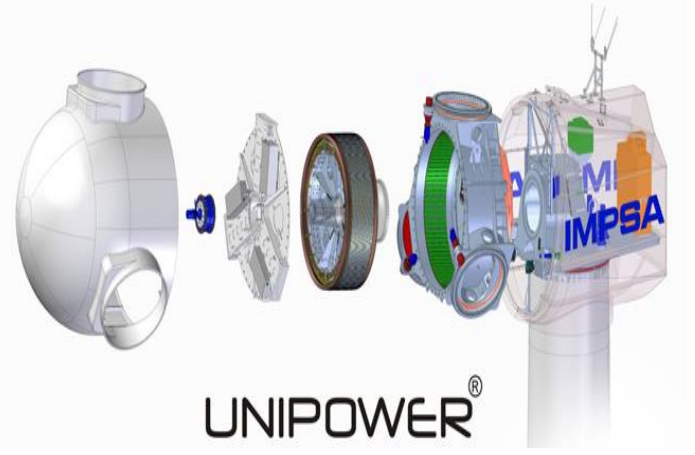

Figure 3. IMPSA wind turbine

Where the stator voltage depends on both grid voltage magnitude and phase:

$$v_{ds} = V \sin(-\theta) \quad (9)$$

$$v_{qs} = V \cos(\theta) \quad (10)$$

The injected active and reactive power into the grid depends on both stator current and grid side current of the converter. Finally equations are as follows:

$$P = v_{ds} i_{ds} + v_{qs} i_{qs} + v_{dc} i_{dc} + v_{qc} \quad (11)$$

$$Q = v_{qs} i_{ds} - v_{ds} i_{qs} + v_{qc} i_{dc} - v_{dc} i_{qc} \quad (12)$$

This can be rewrite by considering converter power equations which are shown below. Grid side converter powers are:

$$P_c = v_{dc} i_{dc} + v_{qc} i_{qc} \quad (13)$$

$$Q_c = v_{qc} i_{dc} - v_{dc} i_{qc} \quad (14)$$

Rotor side powers are

$$P_r = v_{dr} i_{dr} + v_{qr} i_{qr} \quad (15)$$

$$Q_r = v_{qr} i_{dr} - v_{dr} i_{qr} \quad (16)$$

Now, if it is considered that the converter has less losses and a unity power factor on the grid side of the converter, then:

$$P_c = P_r \quad (17)$$

$$Q_c = 0 \quad (18)$$

Finally injected power into the grid

$$P = v_{ds} i_{ds} + v_{qs} i_{qs} + v_{dr} i_{dr} + v_{qr} i_{qr} \quad (19)$$

$$Q = v_{qs} i_{ds} - v_{ds} i_{qs} \quad (20)$$

In generator, motion equation single shaft model is used and it is assumed that converter controls can be able to filter shaft dynamics. For this reason, tower shadow effect is not considered.

3. Ninh Thuan – Binh Thuan24 system

3.1. Background

The system analyzed in this study is a conceptualization of the IV Power Engineering Consulting Company, Vietnam, the grid namely The Electrical System Used in Construction of Ninh Thuan I Nuclear Power Plant. It is invested by Wind Power Energia S/A. The "Ninh thuan – Binh Thuan" test network developed by M.Q. Duong and M. H. Duong in which due to some adjustment to the system model and its parameters, this system is called Ninh Thuan-Binh Thuan24.

3.2. System characteristics

The Ninh Thuan-Binh Thuan24 system is depicted in Figure 4. The first region is formed by the Vinh Tan Thermal Power Company and Da Nhim Hydro Power Company that the equivalent areas located in the upper part, while the second region is formed by the An Phong Wind Power Company including IMPSA wind generator that the equivalent areas located in the bottom part. The system has 24 buses, 19 transmission lines, 19 transformers and 8 generators, most of them are hydro and thermal generators located in the upper part. A 180 MW IMPSA wind power plants based on variable speed generators is integrated at bus 110kV Ninh Phuoc and presented in Figure 5. The parameters of IMPSA wind turbines are provided in Table 1.

Table 1. IMPSA variable speed wind turbine parameters

Parameters		Value
1	Unit power	1.5 MW
2	Diameter	70 m
3	Direction of rotation	Clockwise
4	Number of blades	3
5	Power control	Variable pitch
6	Line side frequency	45 – 65 Hz
7	Generator side voltage	690 Vac
8	Hub height	85 m
9	Cooling	Air IP 23 (EN-60529)

4. Results and Analyses

The impact of IMPSA variable speed wind turbines on Ninh Thuan – Binh Thuan24 test system with wind speed variation input (Figure 2) leads to a small signal stability problem. After solving the power flow problem, the eigenvalues and the participation factors of the test system were computed and visualized. The eigenvalues can be computed for the state matrix of the dynamic system (small signal stability analysis) [10].

The computation of the eigenvalues in the S-domain are shown in Figure 6. Obviously, all poles lie completely on the left hand side as well as the eigenvalues is less than 0. Therefore, it can be concluded that the system is stable.

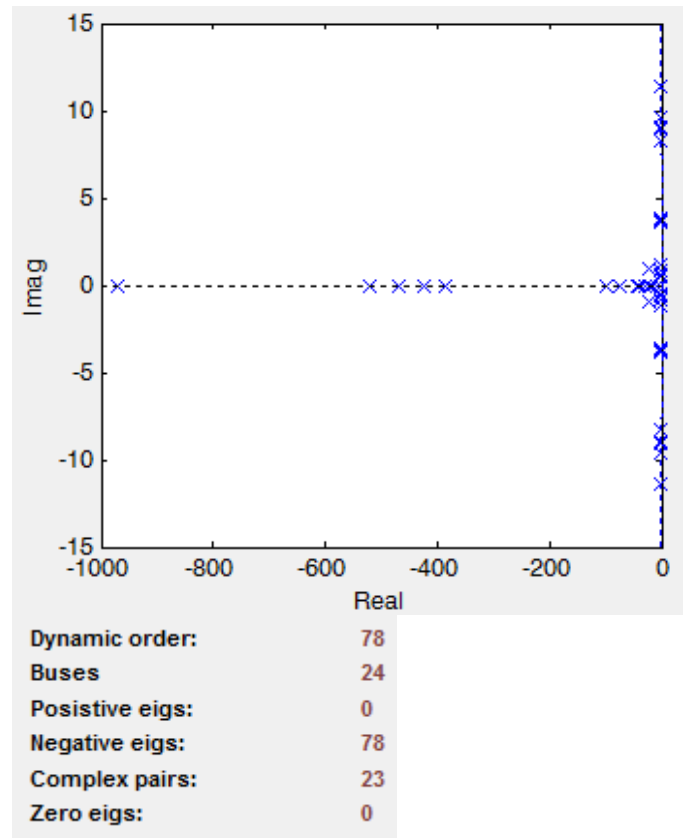

Figure 6. S-Domain analysis graphical representation of Ninh Thuan – Binh Thuan24 test system

Furthermore, In order to ease the visualization of this system it is sometimes useful to compute the eigenvalues in the Z-domain, which can also ease. As can be seen in Figure 7, all the eigenvalues are inside the unit circle. As a results, it can also be concluded that the system is stable.

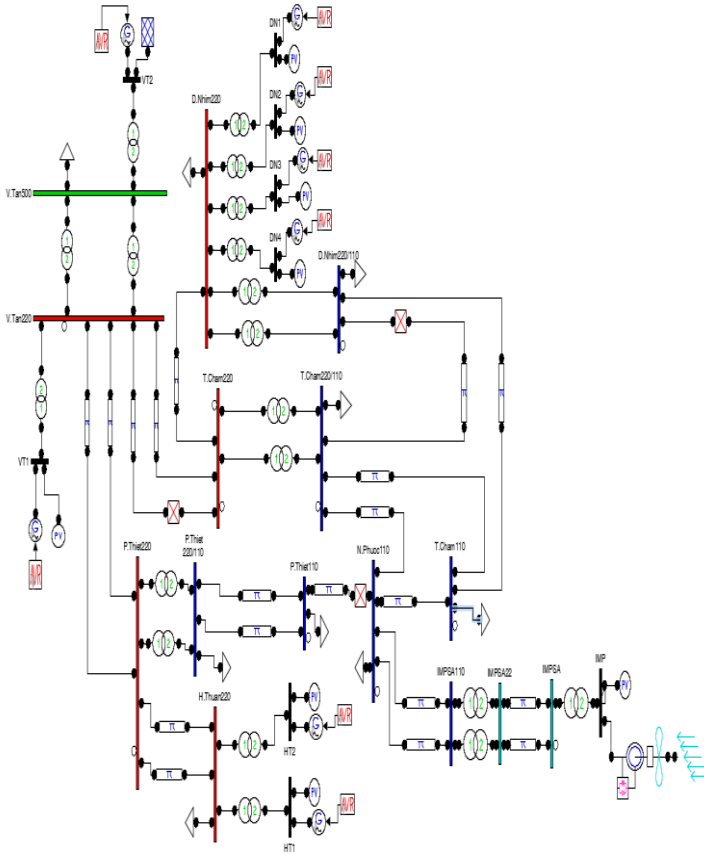

Figure 4. Ninh Thuan – Binh Thuan24 test system

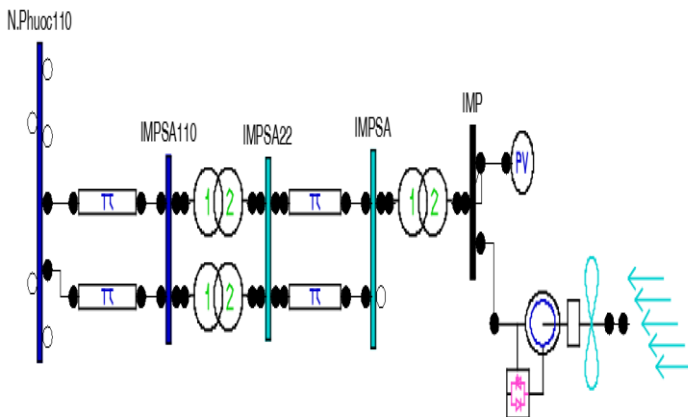

Figure 5. IMPSA wind turbines at bus 110Kv Ninh Phuoc

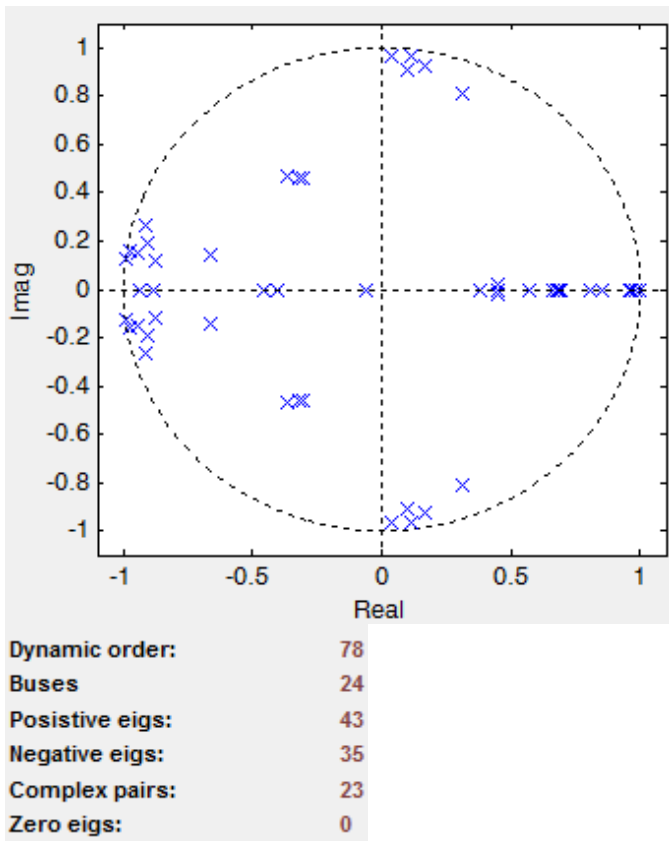

Figure 7. Z-Domain analysis graphical representation of Ninh Thuan – Binh Thuan24 test system

The snap shot small signal stability report depict the eigenvalue analysis for this test system as shown in figure 8.

Eigenvalue	Most Associated States	Real part	Imag. Part	Pseudo-Freq.	Frequency
Eig As # 1	omega_syn_1, delta_syn_1	0.30997	0.81287	0.12937	0.13846
Eig As # 2	omega_syn_1, delta_syn_1	0.30997	-0.81287	0.12937	0.13846
Eig As # 3	omega_syn_2, omega_syn_8	0.03762	0.96511	0.1536	0.15372
Eig As # 4	omega_syn_2, omega_syn_8	0.03762	-0.96511	0.1536	0.15372
Eig As # 5	delta_syn_3, omega_syn_3	-0.91367	0.26421	0.04205	0.15137
Eig As # 6	delta_syn_3, omega_syn_3	-0.91367	-0.26421	0.04205	0.15137
Eig As # 7	omega_syn_3, delta_syn_3	0.10276	0.90648	0.14427	0.14519
Eig As # 8	omega_syn_3, delta_syn_3	0.10276	-0.90648	0.14427	0.14519
Eig As # 9	e1q_syn_6, e1q_syn_7	-0.97233	0.15949	0.02538	0.15682
Eig As #10	e1q_syn_6, e1q_syn_7	-0.97233	-0.15949	0.02538	0.15682
Eig As #11	theta_p_dfig_1	-0.88615	0	0	0
Eig As #12	e1q_syn_2, e1q_syn_8	-0.90262	0.19293	0.03071	0.1469
Eig As #13	e1q_syn_2, e1q_syn_8	-0.90262	-0.19293	0.03071	0.1469
Eig As #14	vr2_exc_1, e1q_syn_1	-0.8785	0.12106	0.01927	0.14114
Eig As #15	vr2_exc_1, e1q_syn_1	-0.8785	-0.12106	0.01927	0.14114
Eig As #16	e1q_syn_3, vr2_exc_3	-0.65879	0.14156	0.02253	0.10724
Eig As #17	e1q_syn_3, vr2_exc_3	-0.65879	-0.14156	0.02253	0.10724
Eig As #18	vr1_exc_8, vr1_exc_2	-0.36857	0.4694	0.07471	0.09498
Eig As #19	vr1_exc_8, vr1_exc_2	-0.36857	-0.4694	0.07471	0.09498
Eig As #20	e1d_syn_1	-0.4058	0	0	0
Eig As #21	omega_m_dfig_1	-0.45736	0	0	0
Eig As #22	idr_dfig_1	-0.06453	0	0	0
Eig As #23	vr1_exc_6, vr1_exc_7	-0.32242	0.45672	0.07269	0.08898
Eig As #24	vr1_exc_6, vr1_exc_7	-0.32242	-0.45672	0.07269	0.08898
Eig As #25	e2d_syn_3	0.80827	0	0	0
Eig As #26	e2q_syn_3	0.37895	0	0	0
Eig As #27	vr1_exc_1	0.57152	0	0	0
Eig As #28	e2d_syn_8	0.66003	0	0	0
Eig As #29	vr1_exc_1	0.68178	0	0	0
Eig As #30	e2d_syn_1, e2q_syn_1	0.45275	0.01819	0.0029	0.07212
Eig As #31	e2d_syn_1, e2q_syn_1	0.45275	-0.01819	0.0029	0.07212
Eig As #32	e2q_syn_1	0.67501	0	0	0
Eig As #33	omega_syn_8, omega_syn_2	0.17065	0.9255	0.1473	0.14978
Eig As #34	omega_syn_8, omega_syn_2	0.17065	-0.9255	0.1473	0.14978
Eig As #35	e2q_syn_8	0.95933	0	0	0
Eig As #36	e1d_syn_5, vr2_exc_5	-0.98849	0.12739	0.02027	0.15862
Eig As #37	e1d_syn_5, vr2_exc_5	-0.98849	-0.12739	0.02027	0.15862
Eig As #38	e1q_syn_8, e1q_syn_2	-0.94055	0.14678	0.02336	0.1515
Eig As #39	e1q_syn_8, e1q_syn_2	-0.94055	-0.14678	0.02336	0.1515
Eig As #40	e2d_syn_6	0.96646	0	0	0
Eig As #41	vr1_exc_2, vr1_exc_8	-0.31833	0.46396	0.07384	0.08955
Eig As #42	vr1_exc_2, vr1_exc_8	-0.31833	-0.46396	0.07384	0.08955
Eig As #43	e1q_syn_7, e1q_syn_4	-0.98849	0.12739	0.02027	0.15862
Eig As #44	e1q_syn_7, e1q_syn_4	-0.98849	-0.12739	0.02027	0.15862
Eig As #45	e2d_syn_2	0.69342	0	0	0
Eig As #46	vf_exc_1	0.98363	0	0	0
Eig As #47	vf_exc_3	0.98363	0	0	0

Figure 8. Ninh Thuan – Binh Thuan24 test system eigenvalue report

5. Conclusion

This research presents the Ninh Thuan-Binh Thuan grid model of which novelty consists in its implementation in a free and open source software: Power System Analysis Toolbox. The model takes into account detailed modeling of the dynamics which play an important role in the assessment of the system's behavior. Of particular significance is the implementation of the recently developed wind turbine and controller model in this tool with Ninh Thuan-Binh Thuan24 test system in which, most of grid's power plants are thermal and hydro generators. Small signal stability analyses of the considered grid utilizing eigenvalue analysis is used to demonstrate the importance of accurate modelling.

Moreover, test system modeling with small signal stability is investigated after injecting wind power with IMPSA variable speed wind turbines. Simulation results show that IMPSA variable speed wind generators are marginally stable.

References:

- [1] M. Q. Duong, E. Oglari, F. Grimaccia, S. Leva, and M. Mussetta, "Hybrid model for ourly forecast of photovoltaic and wind power," in 2013 IEEE International Conference on Fuzzy Systems, pp. 1-6, 2013.
- [2] G. N. Sava, S. Costinas, N. Golovanov, S. Leva, and M. Q. Duong, "Comparison of active crowbar protection schemes for DFIGs wind turbines," in 2014 IEEE 16th International Conference on Harmonics and Quality of Power, pp. 448-552, 2014.
- [3] M. Q. Duong, K. H. Le, F. Grimaccia, S. Leva, M. Mussetta, and R. Zich, "Comparison of power quality in different grid-integrated wind turbines," in 2014 IEEE 16th International Conference on Harmonics and Quality of Power, pp. 669-673, 2014.
- [4] M. Q. Duong, F. Grimaccia, S. Leva, M. Mussetta, E. Oglari, "Pitch angle control using hybrid controller for all operating regions of SCIG wind turbine system," in Renewable Energy A International Journal, pp. 197-203, 2014.
- [5] M. Q. Duong, F. Grimaccia, S. Leva, M. Mussetta, and R. Zich, "Improving LVRT characteristics in variable-speed wind power generation by means of fuzzy logics," in 2014 IEEE International Conference on Fuzzy Systems (FUZZ-IEEE), pp. 332-337, 2014.
- [6] H. Schwarz, K. Pfeiffer, and L. Roskoden, "Integration of renewable eneries to the east German grid. Actual problems and possibe solutions," in Proc. Of the 6th WSEAS International Conference on Power Systems, pp. 7-13, 2006.
- [7] A. G. Pillai, P. Thomas, K. Sreerenjini, S. Baby, T. Joseph, and S. Sreedharan, "Transient stability analysis of wind integrated power systems with storage using central area controller," in 2013 Annual International Conference on Emerging Research Areas and 2013 International Conference on Microelectronics, Communications and Renewable Energy, pp. 1-5, 2013.
- [8] Yanhua Liu and Yongning Chi and Weisheng Wang and Huizhu Dai, "Impact of large scale wind farm integration on power system transient stability," in 2011 4th International Conference on Electric Utility Deregulation and Restructuring and Power Technolgies, pp. 1301-1305, 2011.
- [9] Y. Chompoobutgool, and Wei Li and L. Vanfretti, "Development and implementation of a Nordic grid model for Power System small-signal and transient stability studies in a free and open source software," in 2012 IEEE Power and Energy Society General Meeting , pp. 1-8, 2012.
- [10] F. Milano, "Power System Analysis Toolbox," Version 1.3.4, Software and Documentation, July 14, 2005.

Author's information

Kim Hung Le

Department of Electrical Engineering, University of Science and Technology, Vietnam

E-mail: lekimhung@dut.udn.vn