



Real-time automatic integrated monitoring of barn environment and dairy cattle behaviour: Technical implementation and evaluation on three commercial farms

Lisette M.C. Leliveld^{a,*}, Carlo Brandolese^b, Matteo Grotto^c, Augusto Marinucci^c, Nicola Fossati^c, Daniela Lovarelli^d, Elisabetta Riva^a, Giorgio Provolo^a

^a Department of Agricultural and Environmental Sciences, University of Milan, via G. Celoria 2, 20133 Milan, Italy

^b Department of Electronics, Information and Bioengineering, Politecnico di Milano, via Ponzio 34, 20133 Milan, Italy

^c IBT Systems, via Lomellina 33, 20133, Milan, Italy

^d Department of Environmental Science and Policy, University of Milan, via G. Celoria 2, 20133, Milan, Italy

ARTICLE INFO

Keywords:

Precision livestock farming
Data fusion
Internet of Things
Animal welfare
Dairy cows

ABSTRACT

Due to increasing herd sizes and automation on dairy farms there is an important need for automated monitoring of cow production, health, and welfare. Despite much progress in automatic monitoring techniques, there is still a need to integrate data from multiple sources to create a comprehensive overview and accurate diagnosis of a cow's state. To aid the technological development of data integration, a prototype of an open and customizable automatic system that integrates data from multiple sensors relating to barn environment and cow behaviour was developed. The system integrates data from sensors that measure barn climate (e.g., temperature, humidity, wind speed), air quality (e.g., CO₂ concentration), water use and temperature, the moisture and temperature of the litter and cow behaviour (e.g., lying, eating, ruminating). An external weather system and video recording system are also included. The system's architecture consists of four main elements: sensors, nodes, gateways, and backend. The data are recorded by sensors, then locally processed on custom-developed sensor nodes, and then transmitted via radio channels to local gateways that combine the data from multiple nodes and transmit them to distributed digital storage ("the cloud") via a 3G/4G cellular network. On the cloud, the data are further processed and stored in a database. The data are then presented to the user continuously and in real time on a dashboard that can be accessed via the internet. In the design of the local wireless network, care was taken to avoid data packet collision and thus to minimize data loss. To test the system's performance, the system was installed and operated on three commercial dairy cattle farms for one year. The system provided high data stability with minimal loss and outliers, showing that the system is reliable and suitable for long term application on commercial dairy farms. The system's architecture, communication network, and data processing and visualization applications form an open framework for research and development purposes, allowing it to be customized and fine-tuned before being deployed as a management assistant on commercial dairy farms. Missing elements that should be added in the future are the integration of the data from the milking parlour and cow identification. Algorithms to integrate information from multiple sensors can be added to provide a comprehensive system that monitors all aspects related to cow welfare, health, and production automatically, remotely and in real time, thereby supporting farmers in important management decision-making.

1. Introduction

In recent decades, livestock husbandry has undergone considerable

changes. In the dairy industry, increasing farm sizes and the accompanying automation are posing challenges to the monitoring of cow welfare, health and production, because farmers are less often present on

* Corresponding author.

E-mail addresses: lisette.leliveld@unimi.it (L.M.C. Leliveld), carlo.brandolese@polimi.it (C. Brandolese), matteo.grotto@ibtssystem.it (M. Grotto), augusto.marinucci@ibtssystem.it (A. Marinucci), nicola.fossati@ibtssystem.it (N. Fossati), daniela.lovarelli@unimi.it (D. Lovarelli), elisabetta.riva@unimi.it (E. Riva), giorgio.provolo@unimi.it (G. Provolo).

<https://doi.org/10.1016/j.compag.2023.108499>

Received 28 June 2023; Received in revised form 18 October 2023; Accepted 3 December 2023

Available online 14 December 2023

0168-1699/© 2023 The Authors. Published by Elsevier B.V. This is an open access article under the CC BY license (<http://creativecommons.org/licenses/by/4.0/>).

the farm and lack the time to examine each individual cow on a daily basis (Barkema et al., 2015; Berckmans, 2014; Norton et al., 2019). These changes in livestock farming therefore demand the adoption of novel strategies to monitor and manage dairy cows on farms. This demand has led to the rise of precision livestock farming (PLF) i.e., the “application of process engineering principles and techniques to livestock farming to automatically monitor, model and manage animal production” (De Montis et al., 2017; Wathes, 2010). PLF technologies enable the continuous automatic monitoring of animals and thereby offer support to farmers in the control and management of their animals (Berckmans, 2017; Halachmi et al., 2019; Rutten et al., 2013). Several of these technologies have already been adopted in commercial systems for the dairy industry (Lee and Seo, 2021; Riaboff et al., 2022), e.g., accelerometer-based sensors for oestrus detection (Saint-Dizier and Chastant-Maillard, 2012) and automated milking systems for monitoring milk production and udder health (Jacobs and Siegford, 2012). Economic evaluations of various automated detection technologies have estimated that investing in these technologies increases the annual profit of a farm (Adenuga et al., 2020; Drach et al., 2017; Rutten et al., 2014). Accordingly, the application of such systems on commercial farms is becoming ever more prevalent (Abeni et al., 2019).

Ideally, automatic monitoring of farm animals focuses on providing a complete overview of the state of the animal, including its production, reproduction, and its welfare status. The welfare of dairy cows is multifaceted (Fraser et al., 1997; von Keyserlingk et al., 2009) and encompasses many welfare issues, such as lameness, mastitis, heat stress, reproduction disorders, metabolic disorders, pain, and the disruption of their social environment (Leliveld and Provolo, 2020; Rushen et al., 2008). The diverse and complex nature of these issues can be accurately captured only by integrating information from multiple sources to get a complete picture of a cow’s welfare status (Frost et al., 1997; Leliveld and Provolo, 2020; Wisniewski et al., 2019). Indeed, the performance of automatic detection systems improves as the number of measured parameters increases (Dolecheck et al., 2015; Dominiak and Kristensen, 2017; Jensen et al., 2016).

Despite the advantages of data integration in farm applications, many existing systems measure only one or a few indicators (Lee and Seo, 2021) and offer only limited conclusions regarding the state of an animal. Moreover, to our knowledge, there are currently no commercial systems that integrate measurements of the barn environment (e.g., barn climate and air quality) with cow-based measurements, even though the barn environment is an important determinant of cow welfare (Schauberger et al., 2020). A major hurdle in the practical implementation of data integration is that this requires a complex system architecture to handle the various types of data from heterogeneous sources and to unify and process them in one place. It requires an efficient (wireless) communication system that prevents data collision (which results in data loss) and also prevents transmissions of redundant data (Firner et al., 2010; Khaleghi et al., 2013). The use of Internet of Things (IoT) technologies supports data management by connecting sensors, controllers, operators and objects to communication technologies such as local networks or the internet to form an information-based, automatic, and intelligent network (Zhang et al., 2021). This provides the opportunity to remotely handle and integrate data from multiple sensors through data fusion (Zhang et al., 2021). IoT technology is a central component of “smart farming”, which uses cloud-based platforms to analyse data from multiple sources and provide decision support (Akbar et al., 2020; Fountas et al., 2020). The main components of data processing in smart farming are data collection, data preparation, data processing, decision making and the provision of services to the end user (Amiri-Zarandi et al., 2022). Integration of data should be ensured on the data preparation level by standardizing the data to a predefined format, as well as identifying and deleting duplicated data, addressing gaps in generated data, and validating data sources and contents (Amiri-Zarandi et al., 2022). Thereby, it is vital that the data collected on a farm are reliable (i.e., valid and stable), because incorrect decisions based on

unreliable data could result in high costs to the farm (Amiri-Zarandi et al., 2022). While several technologies have been developed for data integration in agriculture (Alonso et al., 2020; Cruz et al., 2022; Symeonaki et al., 2022), there is still a need for integrated systems that are open and customizable and therefore are suited for research purposes as well as for commercial use.

This paper describes a prototype of an open and customizable integrated automated system to monitor barn environment and cow behaviour simultaneously. Because a major obstacle in data integration is providing a suitable architecture that can handle large data sets from various heterogeneous sources, the aim of this study was to establish a system architecture with a suitable communication network to collect, transfer, process and visualize data from multiple sources continuously and in real time. This system was developed in the framework of the project “Integrated Environment Management System in Dairy Barns to Improve the Welfare and Productivity of Cows (GALA)” an Operational Groups of the Rural Development Programme 2014–2020. Using IoT technology, the resulting system integrates data from multiple diverse sensors that measure barn climate (e.g., temperature, humidity, wind speed), air quality (e.g., CO₂ concentration), water use and temperature, the moisture and temperature of litter and, equally important, cow behaviour (e.g., lying, standing, eating, ruminating) to present a real-time comprehensive overview of the conditions in the barn and the state of individual cows to a farmer. We first describe the architecture of the system (sensors, nodes, gateway and backend) and its communication network, the data processing and the delivery of information to the user through a dashboard. We then document the system’s performance on three commercial dairy cattle farms. Finally, we evaluate the system’s performance and draw conclusions about the feasibility of open and customizable data integration in the automatic monitoring of dairy cows in a commercial setting, as well as about the opportunities and challenges that it presents. It is believed that the results of this project will help promote research-driven data integration in the automatic monitoring of livestock, thereby improving the management of cow welfare, health and production.

2. Materials and methods

2.1. Architecture of the system

2.1.1. Overview

The GALA system was designed to make measurements at three different locations (outside the barn, inside the barn and on individual cows) and to collect, process and analyse the measured data before ultimately presenting it to the user. Outside the barn, measurements included ambient temperature, relative humidity, wind speed and direction, and rainfall. Inside the barn, the measurements consisted of ambient temperature, relative humidity, light intensity, black globe temperature, water temperature and use, litter temperature and humidity, CO₂, NH₃, H₂S, sound pressure level, and wind speed and direction. On the cow, measurements consisted of acceleration. The system architecture is shown in Fig. 1. The system consists of four main elements: the sensors, the nodes, the gateways and the cloud backend (for data processing and analysis and subsequent presentation to the user via a dashboard). The sensors are standard, off-the-shelf components that constitute the elements of transduction of physical quantities either into analog information (voltage or current) or digital data and are physically connected to a node. The nodes are specifically designed hardware/software systems that are physically connected to one or more sensors and are powered either by batteries or by low voltage mains electricity (12VDC).

The nodes are small, embedded devices that integrate all the necessary electronics and implement the firmware to perform three main functions: 1. raw sensor measurements, 2. local data processing, and 3. data transmission. The gateways are larger hardware/software systems that are powered by mains electricity (220VAC; indoor

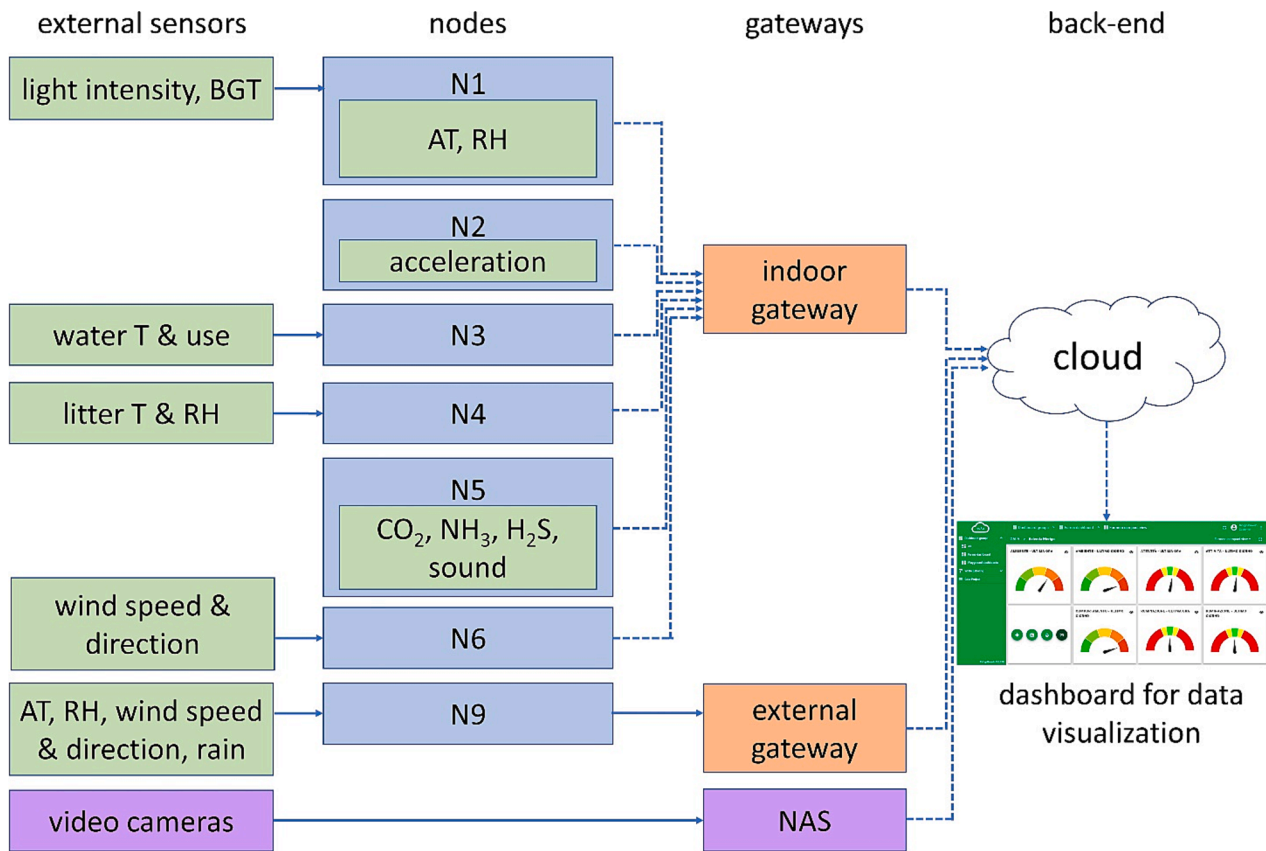

Fig. 1. Architecture of the prototype integrated system described in this paper. External and integrated sensors are presented as green boxes, nodes are presented as blue boxes, gateways as orange boxes and the infrastructure for video registration as purple boxes. Solid lines indicate wired connections and dotted lines indicate wireless connections. BGT = black globe temperature, AT = ambient temperature, RH = relative humidity, T = temperature, NAS = network attached storage. (For interpretation of the references to colour in this figure legend, the reader is referred to the web version of this article.)

gateway) or by a solar panel and a backup battery (external gateway). They collect data from the nodes through the local wireless communication channel and provide connectivity to the backend cloud infrastructure using the MQTT (message queue telemetry transport) protocol over a standard 4G cellular network. The backend system is a software component based on a commercial platform that collects, stores, processes and displays sensor data. Access to these data is provided by means of a complex and complete dashboard presenting all sensor data

in full detail for scientific purposes (e.g., research use), or via a simpler, compact dashboard that provides a summary of the data meant for immediate viewing by a farmer.

2.1.2. Nodes hardware

The nodes are structured according to the general architecture shown in Fig. 2 in which a main board (indicated as GALA-NX), which is specific for each type of node or group of nodes, hosts the analog and/or

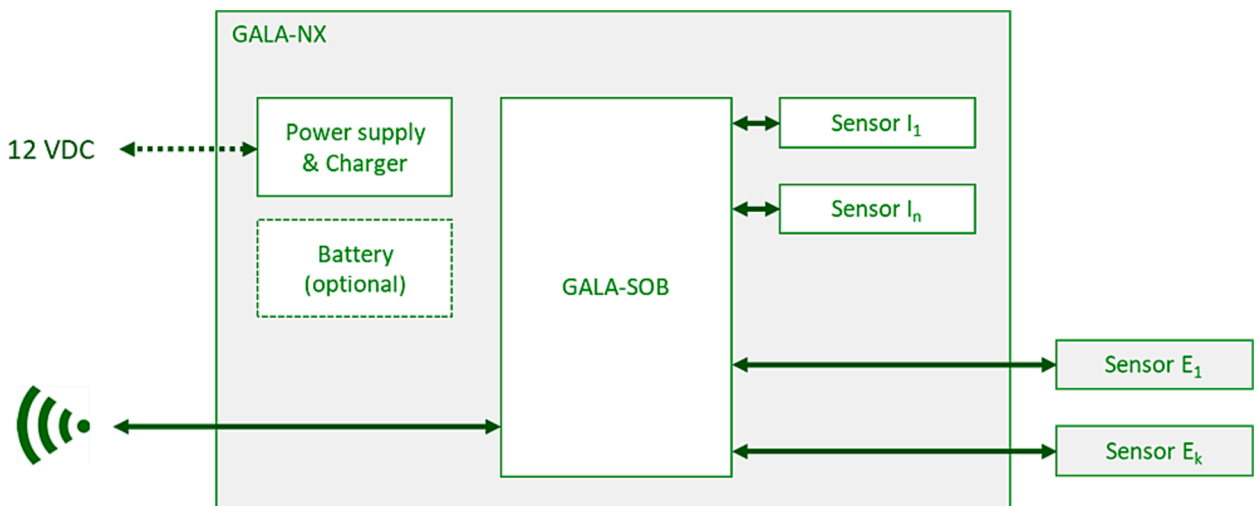

Fig. 2. Schematic presentation of the basic architecture of the nodes. The Wi-Fi symbol indicates the RF868 network.

digital interfaces towards the sensors, the internal sensors, the power supply and battery charger circuitry and the 35 x 45 mm GALA-SOB (system-on-board; Fig. 3). All nodes in this project were built by enhancing this basic design with specific features. In total there were nine different types of nodes created based on the basic GALA-SOB. Of these, seven nodes are used for data collection (N1, N2, N3, N4, N5, N6 and N9), one node (GALA-RF868) is integrated in the indoor gateway and acts as interface from the local wireless 868 MHz network to the cellular network, and one node (GALA-EOL, which is an end-of-line board) was used for programming and testing the GALA-SOB in the laboratory, before deploying it into the specific nodes. Two further nodes (N7 and N8) were developed to read digital inputs and drive digital outputs but these were not installed on the test farms. The specifications of the different node types are listed here:

- GALA-N1. The N1 node is connected to an ambient temperature and relative humidity sensor, a light intensity sensor, and a black globe temperature sensor (Table 1). The temperature and relative humidity sensors are integrated in the node and connected via an I2C bus to the GALA-SOB. The light intensity sensor is also integrated in the node, even if it is mounted on a separate small board, and is placed close to the top of the case enclosing the node to be better exposed to the light. The black globe temperature sensor is externally connected to the board and consists of a standard plastic black globe and an NTC analog sensor. The power supply of the node consists of two C-size primary batteries, connected in series (3 V, 7800mAh). The node is fixed in an opaque case (55 x 80 x 160 mm) with a transparent front for light intensity measurements.
- GALA-N2. The N2 node, described in detail by Lovarelli et al., 2022, integrates one triaxial accelerometer. The electronics of the device are enclosed in a 100 x 75 x 22 mm plastic case having an IP67 rating, which is mounted on a neck collar with a weight at the bottom to keep the node in place on the upper-left side of the cow's neck (Lovarelli et al., 2022). This position enables the detection of ingestion-related behaviours, such as eating and ruminating. For further protection, initially duct tape and later a rubber coating was fixed around the case. The N2 nodes are powered by a single AA-sized, high energy-density, lithium-thionyl chloride battery (3.6 V, 2600mAh).
- GALA-N3. The N3 node is externally connected to pulse-launching flow meters with different sections (1/2in, 3/4in or 1in) to measure water use and waterproof Negative Temperature Coefficient (NTC) sensors to measure the water temperature. Each GALA-N3 node can support up to two flow meters and two NTC probes. The power supply of the node consists of two C-size primary batteries, connected in series (3 V, 7800mAh). The case dimensions are the same as for the GALA-N1 nodes, but N3 cases have an opaque front instead of a transparent one. The node can measure both sprinkler and drinking water use and temperature. In the study reported here, the temperature sensors were activated only in the nodes that measured drinking water.
- GALA-N4. The N4 node is connected via an SDI-12 bus to a digital sensor measuring litter temperature and humidity. This sensor is designed for measuring the temperature and water content of soil, which has granulometric and electrical characteristics different from those of litter material. For this reason, experimental measurements were carried out with litter material to develop a calibration curve for obtaining the litter humidity value. The power supply and the case are the same as described for the N3 nodes.
- GALA-N5. The N5 node is connected to different types of air quality sensors and to a sound pressure sensor, all integrated in the node. Since the CO₂ sensor is based on non-dispersive infrared technology, the power consumption by these sensors is relatively high and cannot be supported by batteries in the long term. Therefore, the N5 nodes are powered by low-voltage mains (12VDC). The N5 node is fitted in an opaque case (55 x 146 x 252 mm) which has a filtered opening to allow the passage of gases for measurement.
- GALA-N6. The N6 node is connected to an external sensor measuring wind speed and direction inside the barn. The sensors transfer the information to the node via two signals: a digital pulse signal for speed measurement and an analog (resistive) signal for direction measurement. The power supply and the case are the same as described for the N3 nodes.
- GALA-N9. The N9 node is essentially a weather station that measures the environmental conditions outside the barn. The node is based on legacy modules directly connected through a Modbus channel to the external gateway and powered by a common power line on a DIN rail system. The DIN rail backplane consists of 5 lines: +12 VDC, ground, lines A and B of the half-duplex RS485 bus, and a generic digital signal used for bus contention and synchronization. The weather station is powered by a solar panel backed-up by a rechargeable battery (12 V, 12 Ah). The GALA-H2O-POWER module controls the

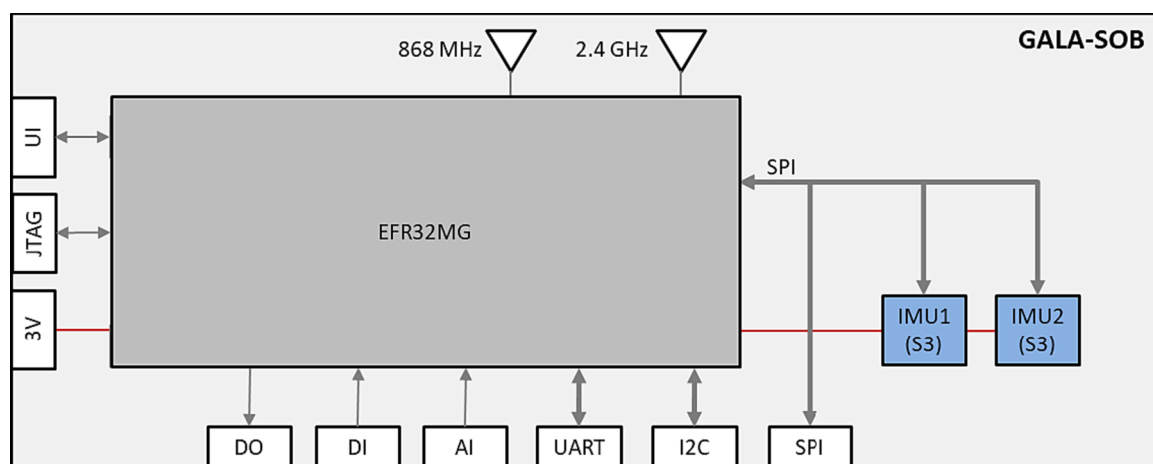

Fig. 3. Simplified schematic of the GALA-SOB. The interfaces for connecting with the specific “host” boards for the different types of sensors are indicated. A simple user interface (UI) controls a status LED and receives input from a pushbutton. The “JTAG interface” is used for the first programming of the device. Digital outputs (DO) are either used as simple digital signals (e.g., to drive relays) or for Serial Peripheral Interface (SPI) sensors. The digital inputs (DI) are used to read isolated dry contacts. Analog inputs (AI) are used for voltage or current sensing, depending on the specific front-end on the host board. Finally, the board exposes standard digital buses: UART, I2C and SPI. The core of the module is the Silicon Labs EFR32BG13 Blue Gecko SiP, featuring two radio channels (868 MHz and 2.4 GHz) with integrated power amplifier and balun and a 40 MHz Cortex M4 core with 512 KB of flash memory and 64 KB of RAM. (For interpretation of the references to colour in this figure legend, the reader is referred to the web version of this article.)

Table 1
Sensors that are integrated in the system, along with the respective nodes. n.s. = not specified.

Node	Sensor	Technology	Measurement	Range	Accuracy (\pm)
N1	Sensirion SHT3x / SHT4x	CMOSens	Ambient temperature	-40 ... +125 °C	0.1 °C
	Sensirion SHT3x / SHT4x	CMOSens	Relative humidity	0 ... 100 %	1.5 %
	Silabs SI1153	ALS Photodiode	Light intensity	0 ... 128 klx	n.s.
	S + S RPTF2 NTC10K	NTC	Black globe temperature	5 ... +60 °C	0.5 °C
N2	Bosch BMA400	MEMS	Acceleration	\pm 16 G	1 mG
N3	Caleffi 7942	Dry contact	Water use	0 ... 4 m ³ /h	n.s.
	Waterproof NTC 10 K	NTC	Water temperature	5 ... +60 °C	0.5 °C
N4	METER teros 12	Resistive / capacitive	Litter temperature	-40 ... + 60 °C	0.1 °C
	METER teros 12	Resistive / capacitive	Litter humidity	0 ... 0.7 m3/m3	0.02 m3/m3
N5	Sensirion SCD30	Nondispersive infrared (NDIR)	CO ₂ concentration	400 ... 10.000 ppm	30 ppm + 3 %
	GS + 4NH3100	Electrochemical cell	NH ₃ concentration	0 ... 100 ppm	1 ppm
	GS + 4H2S	Electrochemical cell	H ₂ S concentration	0 ... 100 ppm	0.1 ppm
	DFRobot SKU:SEN0232	Microphone	Sound	30 ...130 dBA	1.5 dB
N6	Davis Instruments 6410	Dry contact	Wind speed	0.3 ... 100 ms/s	4 %
	Davis Instruments 6410	Resistive, dry contact	Wind direction	0 ... 365°	7°
N9	DHT22	Capacitive / resistive	Ambient temperature	-40 ... + 80 °C	0.5 °C
	DHT22	Capacitive / resistive	Relative humidity	0 ... 100 %	2-5 %
	Davis Instruments 6410	Dry contact	Wind speed	0.3 ... 100 ms/s	4 %
	Davis Instruments 6410	Resistive	Wind direction	0 ... 365°	7°
	Davis Instruments 6466	Dry contact	Rainfall	0 ... 250 mm/hr	4 %

power supply for the other modules and the recharging of the battery via the solar panel. Sensor reading is performed by two I/O legacy modules, namely the GALA-H2O-DIGITAL and GALA-H2O-ANALOG boards. The former reads digital data such as windspeed and rainfall pulsed output, while the latter reads and converts analog data, such as the variable resistance (through a voltage divider) produced by the wind direction sensor.

- GALA-RF868. The module GALA-RF868 acts as the interface between the wireless network in the barn (868 MHz) and the cellular network towards the cloud. This node collects all data from the barn nodes and makes them available through a queue on a standard serial interface (UART) using a Modbus remote terminal unit protocol. Through this interface, the indoor gateway reads data for packing and transmitting it to the cloud. The GALA-RF868 board has the same mechanical structure as the GALA-H2O boards and is also connected to the DIN backplane.
- GALA-EOL. A GALA-EOL board was created as a support for testing and diagnostics of the GALA-SOB. This board was not installed on the farms but rather used as a support tool in a laboratory. It was used during the development of the system and for debugging during the testing phase.

2.1.3. Sensors

A list of the sensors and their description is provided in [Table 1](#). Selection of the parameters that are relevant for the monitoring of cow welfare, health and production was based on a review of relevant literature (e.g., [Hoffmann et al., 2020](#); [Rushen et al., 2008](#); [Dittrich et al., 2019](#); reviewed in [Leliveld & Provolo, 2020](#)). For the selection of the sensors, literature research was performed to understand the range and accuracy requirements for measuring all included parameters in a dairy cattle barn environment. The sensors were then selected by evaluating their capability to provide accurate measurements in the desired range and their compatibility with the rest of the system, whilst aiming to keep costs, power consumption, and complexity low. As shown in [Figs. 1 and 2](#), the sensors are externally or internally connected to the nodes. The external connection can be relatively close to the node (e.g., the black globe thermometer that is built on top of the node case) or remote. For instance, the water flow sensors and the associated thermocouples that measure water use and temperature were mounted on the water distribution pipes of the drinking troughs and/or sprinklers for cooling the cows and connected to the nodes via long cables.

2.1.4. Node firmware

The node firmware collects the data from the sensors, pre-processes

the raw sensor readings (see [Section 2.3.1](#)) and sends data to the gateway. The collection of data from the sensors is done through standard protocols for those sensors that directly expose a digital interface such as SPI, SDI or I2C, or by reading the sensor's output voltage or current through an analog-to-digital converter and transforming it into the target physical measure according to specific mathematical models. To optimize the performance of the nodes and increase reliability and battery life, the firmware was developed to maximize the idle time of the system (during which time the microcontroller and, if possible, the sensors are switched to low-power mode or turned off) and to obtain the best trade-off between local computation and data transmission. Like the hardware of the nodes, the firmware was also developed in a modular way with the support of an embedded operating system, generic drivers for the sensors, data acquisition functions, Bluetooth communication protocol and local wireless communication protocol that are common to all sensors. On top of this common layer, each node implements a specific application layer.

2.1.5. Gateways

Both the indoor and external gateway act as a connection between the local network and the internet. The indoor gateway connects the local RF868 network and the global cellular network. It obtains data from the nodes in the barn via the local radio interface module (GALA-RF868) and communicates them to the backend infrastructure (cloud). The gateway hardware consists of a NAS (network attached storage), which is also used for video recording (Synology DS210j, Synology, Banciao, New Taipei, Taiwan). The gateway software continuously polls the GALA-RF868 module to verify whether new data from the nodes are available and, if so, copies such data to a large temporary buffer that has the capacity to store data for a few days. Periodically, the gateway software merges data in the buffer into a single, compact MQTT binary packet and sends it to the cloud. The external gateway is implemented by the legacy GALA-H2O-MAIN module which acts as Modbus master for collecting data from the other modules of the N9 sensor node, combining such data in a single packet for optimization, buffering individual packets in case of network absence and, eventually, sending the stored data packets to the cloud backend via a 3G/4G cellular module.

2.1.6. Video recording system

The internet protocol video cameras that are used for video recording are compatible with the Open Network Video Interface Forum specifications and are powered via PoE (Power over Ethernet). This solution allowed a single Ethernet cable per camera to be used for power supply, as well as video streaming and remote control. As shown in [Fig. 1](#), the

cameras are connected via ethernet cables through a PoE switch to the NAS where specific commercial software acts as a network video recorder. Remote access to the video recording system is granted, through a 4G modem, and locally via a wired ethernet connection and a WiFi network. A remote web-based interface provides visualization of the barn and control of the system, both for configuration and diagnostics.

2.1.7. Backend

The backend is a custom cloud software application, partly built on top of the commercial platform Thingsboard (v.3.2.2PE), that collects, stores, and processes data that is received from the gateways. As Fig. 4 shows, messages are not sent directly to the Thingsboard MQTT broker, but first to a custom-built intermediate MQTT Broker that performs several transformations, both on the upstream telemetry data flow and on the downstream bidirectional remote processing calls and attribute data flows. Considering the telemetry data flow, the following list describes the operations that the intermediate server performs:

1. A component called “Splitter” is subscribed to the MQTT topic where packed telemetry messages are received and it unpacks these messages into individual, node-level messages. This process is agnostic with respect to the structure and contents of the messages. Unpacked messages are then published, as binary packets, to the same intermediate broker on a second topic.
2. A component called “Decoder” is subscribed to the second topic created by Splitter. Decoder is aware of the internal structure of the messages and has the task of interpreting the content of the individual binary messages and publishing it back to the broker in Java script object notation (JSON) format on a third topic.
3. The Thingsboard hub is subscribed to the JSON telemetry topic of the intermediate MQTT broker and allows transmitting data from different devices (all the nodes connected to a specific gateway) through a single connection using a unique key related to the gateway (rather than to the single nodes). Then, the Thingsboard hub associates each logic device (i.e., the logical entity that is needed to represent the data on the Thingsboard platform) with the

corresponding physical node based on the node name specified in the JSON telemetry message.

4. The telemetry is published to the Thingsboard internal broker, where it is saved in the database in the form of a timeseries and enters the processing chain. The Thingsboard was customized using a graphical (NodeJS) and programmatic (Javascript) formalism, referred to as “rulechains”, to perform medium–low complexity processing (see Section 2.3.2)

2.2. System communication network

To minimize power consumption and to support a large number of devices, a custom-TDMA (Time Division Multiple Access) wireless communication protocol was developed on the raw physical 868 MHz GFSK modulation scheme provided by the EFR32BG13 core used in the GALA-SOB. The 868 MHz carrier was chosen to minimize signal attenuation due to the presence of animals. This protocol allows bidirectional communication between the nodes (master) and the gateway (slave). A time-slotted approach is used for data transmission to avoid packet collision from different nodes transmitting at the same time. This approach reduces the need to retransmit, thereby reducing energy consumption at the nodes and maximising battery life. Based on an autonomous initial negotiation scheme, each node is assigned a specific timeslot of 1 s within the global communication period (called an “epoch”), which is set to 10 min (600 s, as described in Supplementary Material 2, Figure S1). The network synchronization is centralized and is performed by the gateway. At the end of the initialization phase, the gateway starts receiving messages from the nodes, nominally every second. The actual timing of each node, though, is based on its own clock, which unavoidably drifts over time with an approximate speed of 50 s per million seconds. This means that approximately every $10^6/50 = 20,000s \approx 5.5h$ a node leaves its nominal slot and transmits either in the previous or the next one. To compensate for this drift, the gateway, upon receiving a message from a given node, determines the difference between the nominal time at which the message was expected and the actual time at which the message was received. This allows computing the exact actual time until the next transmission of that node. This

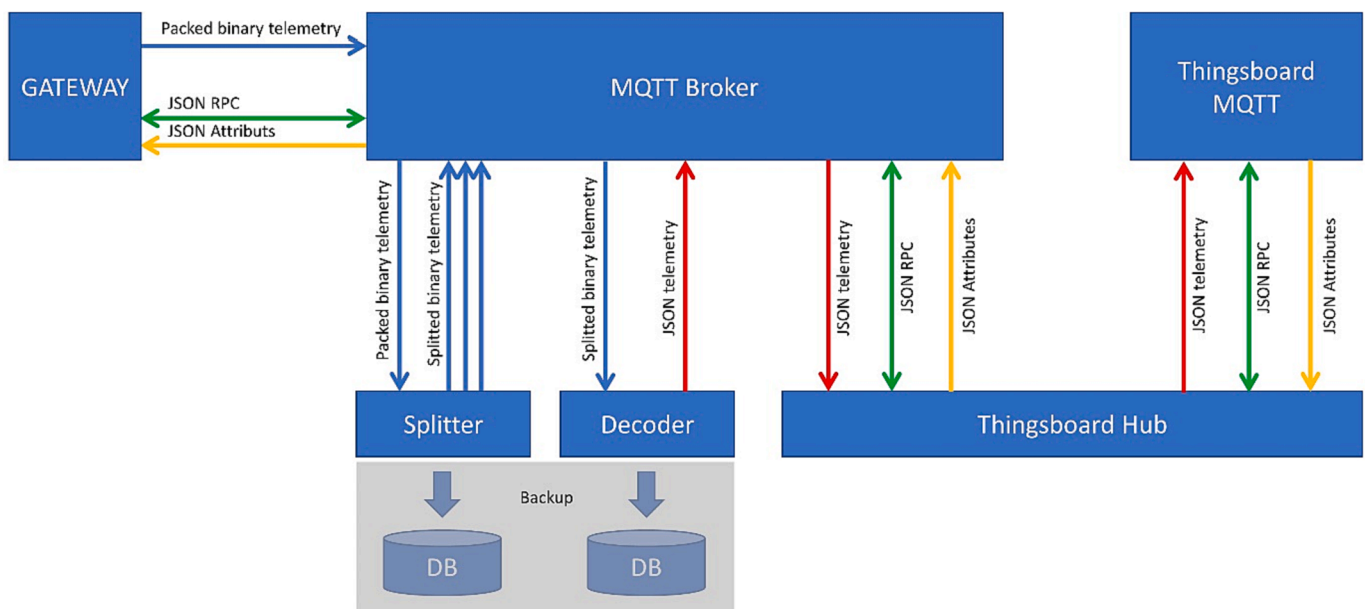

Fig. 4. Schematic representation of the cloud software infrastructure. The blue arrows indicate the binary data that originated from a sensor, packed when generated from the gateway and split into single packets when exiting the splitter; the red arrows indicate the telemetry decoded in JSON (Java Script Object Notation) format; the green arrows indicate RPCs (Remote Procedure Calls) used to perform some actions on the nodes; the yellow arrows indicate nodes’ attributes, used to configure some parameters of their behaviour. DB = Database, MQTT = Message Queue Telemetry Transport. (For interpretation of the references to colour in this figure legend, the reader is referred to the web version of this article.)

information is sent back to the node, which can thus adjust its timing and compensate for the clock drift. This way, the drift is compensated at each period of 600 s and its worst-case value is $600 \cdot 50 / 10^6 = 30$ ms. To avoid overlapping, a silence guard time is respected at the beginning of each time slot.

The maximum size of each transmitted packet is 250 bytes (including the communication “overhead”), which, with a bandwidth of 26 Kbit/s, requires a maximum time of 80 ms. At the end of transmission, each node remains active for a short period of time (20 ms in the current implementation) to wait for the answer from the gateway containing synchronization and other control information. After receiving the gateway response, if any, the node enters its deep-sleep mode.

During the initial negotiation phase, the following procedure is used. Each node, which has a unique numeric identifier, transmits (at a random time) an initial packet containing the data and its identifier to the gateway. In case of collision with other packets, the same transmission will be repeated after a short interval, which is also random. The gateway, knowing the node identifier, computes the delay the node must wait for the next transmission to fall in its correct slot and indicates the waiting time until the start of the node’s next slot in the response message to the node. For example, if node 35 transmits for the first time 330 ms after the beginning of time slot 250, the gateway assigns the new node slot 35 and indicates that the delay to the next transmission is 384.67 s (computed as $[600 - 250.330] + 35 = 384.67$ s; i.e., the time till the beginning of the next epoch, plus the delay from the beginning of the next epoch to the correct slot). In this case, therefore, the gateway indicates the retransmission time as $350 + 35 = 385$ s. This mechanism simultaneously guarantees two important properties: on the one hand – except for an initial transient of 20 or 30 min – it eliminates packet collisions, and, on the other hand, it synchronizes the time of all nodes with that of the gateway. Data from the nodes are encoded in binary packets to reduce size, transmission time and energy consumption. Two different basic packet structures were defined: one with a 16-bit mask, suitable for encoding up to 16 different measures, and a larger one, with a 32-bit mask, which extends the allowed measures up to 32. The structure of these packets is shown in [Figure S2 \(Supplementary Material 2\)](#).

The gateway transmits the data periodically to the backend infrastructure in the cloud on the internet using a MQTT protocol (MQTT version V3.1 protocol, configured with quality of service “1”; [OASIS, 2023](#)). In addition to the RF868 and global protocols, a Bluetooth protocol ([Bluetooth, 2023](#); [SIG 2023](#)) is used for the local connection between the individual nodes and a service mobile application (app). To achieve this, each node implements a Bluetooth channel for local and short-distance communication and an app was developed to connect to this channel via a smartphone. This app is used for data collection, sensor configuration, diagnostics, and software updates of the nodes. The app and the Bluetooth channel were also used to collect combined accelerometer data and behavioural observations for the development of an algorithm to categorize cow behaviour (for details see [Lovarelli et al., 2022](#)).

2.3. Data processing

Data processing is distributed across the system and is partly performed on the nodes and partly on the cloud. The gateways do not perform any processing, being only responsible for buffering of the packets coming from the nodes and packing them into larger packets to minimize communication overhead.

2.3.1. Data processing on the nodes

The processing performed by the nodes on signals that change slowly over time is relatively simple and includes basic statistical analysis, filtering, and transformations, such as scaling and offsetting. Statistical analyses include the calculation of the mean and, for some

measurements such as wind speed and sound level, also minimum and maximum values within a 10-minute interval. Some “noisy” quantities (e.g., signals that change rapidly over time and signals affected by electronic or thermal noise) are sampled at a rate higher than needed and then are filtered using a moving average or Butterworth digital filter and, in some cases, decimated. The processing on the cow nodes (N2) is much more complicated and computationally intensive than that on the other nodes. Details on the processing of the behavioural data and the development of the algorithm have been published in [Lovarelli et al. \(2022\)](#). In short, acceleration in the three dimensions is sampled at a frequency of 25 Hz and processed in 5-second windows to compute data features to be used to classify the dominant behaviour over each 10-minute interval. Each 10-minute interval consists of $(600 / 5 =)$ 120 windows, and thus 120 samples per each of the 10 features are computed. The behavioural classification algorithm was developed by applying machine learning on the features that were extracted from accelerometer data, which were collected during 108 h of observations from 32 cows on three farms. This algorithm, which is based on a decision tree model, was shown to correctly classify the cow behaviour into six different classes, i.e., “standing”, “lying down”, “standing and ruminating”, “lying down and ruminating”, “eating” and “other”, with an average accuracy of 85.12 % ([Lovarelli et al., 2022](#)).

2.3.2. Data processing on the cloud

On the cloud, the data go through a processing flow implemented within the Thingsboard platform. On this platform, data are characterized according to the farm, the sensor identifier, the sensor type, the type of measure, the timestamp and the value (i.e., the actual measurement made by the sensor). As mentioned in [Section 2.1.7](#), the processing that occurs on the Thingsboard platform is based on rule chains, which graphically represent the paths and the different processing steps for the different types of data. Rule chains are activated either by the arrival of new data or by the triggering of a periodic timer. When data arrive in the cloud, they are first processed by the root rule chain (see [Supplementary Materials, Figure S3](#)). This rule chain basically sorts the data towards secondary rule chains for each specific node type. An overview of the input timeseries, computed timeseries, and computation process is provided in the [Supplementary Material 1 \(Table S1\)](#). Many values are obtained by combining the same type of data collected in the same time interval by several sensors (e.g., combining the temperature measurements of the different N1 sensors to calculate the mean temperature in the barn). Other values are obtained by combining multiple measurements in the same time interval from the same sensor node (e.g., combining the temperature and humidity measurements to calculate the temperature-humidity index [THI]). Some other values are obtained by combining the same measurement over a certain time interval. Indeed, for all values, hourly and daily averages, as well as more complex statistical values, are calculated. For example, the “standing rate” is calculated as the fraction of time spent standing during the last hour or day, and the “daylight exposure” is based on the time having a mean light intensity greater than 40 lx.

A specific node of the rule chains is used to raise alarms. For environmental barn sensors data, the alarm uses fixed thresholds (e.g., if the mean barn THI increases above 72, the first level of alarm is raised and visualized on the dashboard). For the behavioural data, a more complex dynamic threshold is used in which the deviation of a measurement from the average of the same measurement over the last 30 days is calculated.

2.4. Dashboard

The dashboard in this project served two purposes. First, it was developed to present the collected data to the end user (usually a farmer) in a concise and accessible manner with the aim to provide quick and clear support in the farmer’s decision-making processes. Secondly, because the project described herein concerns a pilot system that also serves scientific purposes, the dashboard also needed to present all data

gathered by the individual sensors in a detailed and complete manner that allowed verification of the system’s functionality and accuracy of the recordings. The dashboards were developed within the Thingsboard platform and were made accessible via hypertext transfer protocol to make it readable both using a computer’s browser and a mobile device. The home page shows the list of the three commercial farms and their location on the map (see [Supplementary Material 2, Figure S4](#)). The detailed (diagnostic) and simplified (farm) overviews for each farm can then be accessed by clicking on the respective icon next to the farm name. A description of the detailed overview is provided in the [Supplementary Material 2](#).

The farm main page shows a series of synthetic alarm graphs that display the alarm level, ranging from green (safe) to red (danger) for different monitored aspects of the farm, together with a needle that indicates the current alarm level (Fig. 5). The thresholds for the different alarm levels are shown in [Table S2 \(Supplementary Material 2\)](#). Alarm graphs are shown for the barn environment of the last hour and the last 24hrs, cow activity in the last hour and last day, cow behaviour in the

last day and rumination in the last hour and day. The level indicated on the barn environment graph is based on a summary from different individual measures, such as THI. Pop-up overviews show the values of individual measures and the level of alarm for each. The farm main page also provides access to more detailed pages on the barn environment, cow behaviour and water and litter. The page dedicated to barn environment displays graphs (with the same features as for the previously described graphs) of means from N1, N5, N6 and N9 sensor nodes (e.g., temperature, ammonia concentration), as well as other computed values (e.g., THI, total daylight exposure and differences in these values between inside and outside the barn). The page dedicated to cow behaviour displays a table with the data gathered on individual cows. This table includes for each cow, the collar identifier, the cow identifier, and the percentage of time spent standing, lying down, eating, ruminating, and in other behaviour, as well as the mean activity level in the last 24 hrs (see [Supplementary Material 2, Figure S6](#)). The percentages are given in colours ranging from green to red, which indicate the alarm level for each individual cow and behaviour. The cow identifier can be



Fig. 5. Above: the farm main page with the alarm graphs shown for the different aspects of the farm (e.g., barn environment in last hour). Needles indicate the current alarm level, ranging from green (safe) to red (danger). For activity and rumination (the four graphs on the right of the screen) any strong deviation from the normal level is considered cause for alarm, hence the middle is green (safe) and yellow and red levels are shown on each side. The icons in the lower left section of the screen provide access to more detailed information on all measurements related to barn environment, cow behaviour and water and litter. Below: example of a graph displaying the values of different climate parameters (THI, humidity and temperature) over the last 7 days (at the time the graph was made). Different y-axes are given for THI and humidity (on the left) and temperature (on the right). Time is shown on the x-axis. Because the dashboard was designed to be understandable to Italian farmers, the information is provided in Italian. (For interpretation of the references to colour in this figure legend, the reader is referred to the web version of this article.)

manually entered and changed if the collar switches owner. This page also provides access to pages for individual cows. On these pages, there is a radar chart showing the average time the cow spent exhibiting the different behaviours, a list showing the dominant behavioural category during the most recent 10-minute intervals, and a graph showing the mean activity of the cow for a selected period. The layout of the page dedicated to water and litter is similar to the page on barn environment, with all data (e.g., global drink water use, mean litter temperature, and mean litter humidity) displayed in graphs.

2.5. Functionality assessment on commercial farms

2.5.1. Farms

The installation of the system on the test farms, which included the mounting of collar-based sensors on the cows, was approved by the Ethics Committee of the University of Milan (n. 25 of 1 March 2022). The system was installed on three commercial dairy cattle farms in the province of Cremona (Lombardy) in Northern Italy. These farms have been described in detail by Lovarelli et al. (2022). Briefly, the monitored barns host Italian Holstein dairy cows in a loose-housing system with free stalls and straw or solid digestate as litter. In the first farm, the system was installed in a barn area having a floor area of 1020 m² with an outdoor loafing area of 47 m² that had two lines of cubicles and housed on average 120 lactating cows. One side of the barn was open, while the other three sides had walls. In the second farm, the monitored barn area had an area of 1324 m², was open on all sides, contained two lines of cubicles, and housed on average 145 cows. In the third farm, the system was installed in a barn that had an area of 920 m² that was open on all sides. The area consisted of three cubicle lines and housed on average 115 lactating cows. All monitored areas had fans above the lying area and sprinklers above the feeding area (on farm 3, sprinklers were installed in July 2021). Cows were milked twice a day and feed was provided once per day on all farms.

2.5.2. Installation

Before installation on farms each sensor node was first tested in the laboratory under controlled conditions and then “commissioned”, i.e., it was assigned its type (e.g., N1, N2), received a unique identifier and was assigned to a farm. The number of sensors, their locations and the method of installation varied between farms depending on the barn structure. Table 2 shows the number of sensor nodes that were installed on each farm. In the case of multiple sensors of the same type, care was taken to position the sensors in the barn in a way that assured mean values of sensor readings would best reflect the situation of the entire barn. Therefore, the positions of the sensors were dispersed and covered different areas of the barn as much as possible (see Supplementary Material 2 Figure S7 for an example of an installation plan on one farm). Pictures of some mounted sensors are shown in Figure S8

Table 2

The sensor nodes and other elements of the system that were installed at each farm (not including replacements).

Sensor nodes	Farm 1	Farm 2	Farm 3
N1: temperature, humidity, light	4	4	4
N1: temperature, humidity, light, black globe temperature	4	4	4
N2: cow behaviour	60	60	60
N3: drink water use & temperature	0	3	4
N3: sprinkler water use	1	1	1
N4: litter temperature & humidity	0	0	4
N5: CO ₂ , NH ₃ , H ₂ S, sound	2	2	2
N6: wind speed & direction	3	3	3
N9: temperature, humidity, rain fall, wind speed & direction	1	1	1
Indoor gateway	1	1	1
Video cameras	4	4	2

(Supplementary Materials). The N1 nodes were placed at an approximate height of 2.5 m above the floor, which is just out of reach of the cows. The nodes on the outer columns were directed to face inside the barn to avoid direct sunlight exposure. Where possible, sensors were mounted on the walls using magnets. In other cases, they were mounted on 3-m long poles that were fixed to the cubicle barriers. The N3 sensors were installed to monitor sprinkler and drink water (depending on the accessibility of the water pipelines) on a group level (i.e., group of cows). On farm 1, it was not feasible to install N3 sensors to measure drink water, because the only accessible water supply pipeline served the entire farm. On the other farms, the number of installed drink water sensors depended on where they could be installed. On farm 3, the sensors (and their nodes) were installed at every drinking trough (four in total), while on farm 2, one sensor node was installed at the central pipeline to measure drink water use and two sensors were installed at the drinking troughs to measure the temperature. The litter sensors (N4) were only installed on farm 3, because the structure of the cubicle floors in the other two farms was not suitable for burying the sensors. On farm 3, the sensors were buried in the middle of the cubicle, deep in the litter in a compartment that was protected by rubber walls. The node was buried in a similar compartment in the litter between two adjacent cubicles and the connecting cable was also buried (see Supplementary Materials, Figure S8). The air quality sensor nodes (N5) were, like the N1 sensors, installed about 2.5 m high on the walls of the barn or on metal poles that were fixed to the ceiling. The wind sensors nodes (N6) were, like some N1 sensors, fixed on poles that were either fixed between cubicle barriers, on the feeding alley, or attached to the walls of the barn (2.5–3 m high). The weather station (N9) was positioned in a field adjacent to and about 50–120 m from the monitored barn area. The N9 node, sensors and solar panels were all fixed to a large iron pole (2–4 m high) that was fixed in the ground using a concrete slab. The number of video cameras that was installed depended on the size of the monitored area (two at farm 3 and four at the other farms). The cameras were mounted on a wall, close to the ceiling to maximize the area that could be monitored. The indoor gateway was installed just outside the monitored area, about midway on the longer side (to minimize the distance to all nodes). At each farm 60 collar-mounted N2 sensors were put on semi-randomly chosen cows, preferring cows that were early in lactation. Whenever a cow was removed from the monitored area (e.g., due to drying off) the collar was put on a fresh cow.

2.5.3. Maintenance

The system’s functioning was checked weekly via the online dashboard, using the diagnostics page. Gaps in energy supply, unusual measurements and incidences of packet rolling number errors and resets were recorded in a spreadsheet file. The farms were also visited at intervals of 1–2 weeks to check and clean the sensors (with a damp cloth). If any problems with a sensor could not be resolved on the farm, the sensor was taken to the laboratory for closer inspection and repair or replacement. Spiderwebs were removed from the cameras using a dry cloth on a long wooden pole.

2.5.4. Data collection and processing

Data were downloaded from the dashboard and saved in a database (in spreadsheet/ database format). After downloading the data, they were filtered to exclude outliers. The filter that was used and the acceptable ranges for each parameter are included in the Supplementary Material 2 (Table S3). To understand how much variation in a specific parameter across a barn could be expected, correlations were calculated between different sensors of the same type using the CORR procedure (Spearman, Fisher [using Fisher’s z-transformation for correlation statistics]) in the statistical software SAS 9.4 (SAS Institute Inc., Cary, NC, USA). In addition to the data that were collected by the system, data for milk yield and quality (where possible from individual cows), health and fertility events, IDs, birth date and calving dates of the monitored cows, and events in the monitored areas that could affect cow behaviour (e.g.,

veterinarian visits) were recorded by the farm personal. These data were obtained either from an installed commercial monitoring system (Afi-milk Ltd, Kibbutz Afikim, Israel; farm 1) or from the Regional Association of Farmers in Lombardy (ARAL; farms 2 and 3).

3. System performance

3.1. System operation

The integrated monitoring systems were operational on the three farms for one year. This period served not only to verify the suitability of the system to collect data in a barn environment and to collect data for analyses, but also for problem solving and fine-tuning. Therefore, not all nodes were continuously installed and functioning on the farms during this period. The number of sensor nodes that were installed and functioning in each month are shown in the [Supplementary Material 2 Table S4](#). Some problems encountered, such as loss of sensors, water damage and case damage, were due to the prototype nature of the system. In addition, the entire system on each farm was affected by power outages. Delays in turning on of a system occurred because the system had to be turned on manually on site after a power outage. In total 24 days on farm 1, 26 days on farm 2 and 33 days on farm 3 were missed due to this problem. The accelerometer nodes (N2) had an average lifetime (i.e., time until the node stopped working or had to be removed due to malfunctioning) of 340 days, and 141 out of 180 installed nodes (including replacements) were still functioning at the end of the test period. Consequently, the lifetime of these nodes can be expected to be much higher than what could be assessed in only one year. Of the 256 battery powered sensor nodes (including replacements), 11 nodes needed a battery replacement, meaning that the majority of the nodes could correctly function at least for one year on their initial batteries.

3.2. Data stability

[Table 3](#) shows the percentage of data (10-min data points) that were actually collected out of the total data that could potentially have been collected, based on the calculation of the total number of 10-min intervals in which each node was installed and functioning without evident problems (e.g., due to identified hardware or software malfunctioning, batteries getting loose) and in which there was no general power outage. These results give an indication of the data collection stability of the system. As [Table 3](#) shows, the percentage of data collected for most sensors exceeds 90 %. Exceptions were the weather stations on all three farms, which often experienced problems with collecting temperature and humidity data. These problems were due to the communication channel of the temperature and humidity sensor which proved unreliable under long-term external weather conditions. The somewhat lower data collection percentage for the N2 nodes can be largely ascribed to temporary removal of the cows from the monitored areas during milking. Because the milking parlours were not located in the monitored section and because they were enclosed by walls, the data

Table 3

Percentage of collected 10-min data points of the total data points that could potentially have been collected per farm. The potential data points were calculated as 6 x 10-min intervals x 24 h x days on which the sensor node was installed and functioning without diagnosed problems. The total data points are sums of the data collected by all sensor nodes per farm.

Node	Total collected (N)			Total potential (N)			Percentage collected (%)		
	Farm 1	Farm 2	Farm 3	Farm 1	Farm 2	Farm 3	Farm 1	Farm 2	Farm 3
N1	1,509,201	1,519,732	1,399,032	1,542,324	1,557,648	1,421,298	97.85	97.57	98.43
N3	97,391	205,553	141,794	98,280	215,154	143,292	99.10	95.54	98.95
N2	3,477,137	4,050,255	3,959,231	3,891,324	4,268,040	4,112,244	89.36	94.90	96.28
N4			351,901			375,322			93.76
N5	581,220	591,058	552,649	589,680	599,328	569,987	98.57	98.62	96.96
N6	522,814	574,012	577,684	529,032	582,048	585,317	98.82	98.62	98.70
N9	214,076	219,195	113,406	264,456	264,456	133,056	80.95	82.89	85.23
Total	6,401,839	7,159,805	7,157,091	6,915,096	7,486,674	7445923,2	92.58	95.63	96.12

transmission from the collars to the gateway was slightly impaired when the cows were in the parlour. The calculated percentages concern the 10-min data points collected from all installed sensor nodes. However, for purposes of monitoring and analyses, hourly data and data based on means from different nodes of the same type is more suitable than using 10-min data or data from individual nodes in most cases. Therefore, the percentage of usable data in such cases is still higher than displayed in [Table 3](#), since for calculating means (from sensors and/or per hour), some missing data points could be acceptable, depending on the data type.

3.3. Outliers

[Table 4](#) shows the number of outliers that were excluded based on the acceptable data ranges (which are shown in the [Supplementary Material 2 Table S3](#)). Any data point that did not fall within the accepted range was considered an outlier and excluded. [Table 4](#) shows that the number of outliers for most sensor nodes was less than 1 %. Nevertheless, the deviations of the outliers from the accepted data range were considerably large on several occasions (resulting in clear changes in the mean values, as can be seen in [Supplementary Material 2 Table S5](#)) and therefore would have considerable effects on any analyses based on the data. The percentage of outliers was larger for the N1 nodes than for other nodes, which was due to the humidity sensors often measuring 100 % humidity. Although this value may indeed be accurate on some occasions, this value was disproportionately measured by the sensors, likely due to droplets gathering on the humidity sensor (a problem that was later solved by fixing a special polytetrafluoroethylene polymer on the sensor). Therefore, to exclude these erroneous values, relative humidity values above 99.9 % were filtered out. Indeed, from February 2022 (when the problem was solved) onwards, the percentage of outliers in the humidity data was below 1 %.

3.4. Inter-sensor correlations

[Table 5](#) shows the correlation between different sensors of the same

Table 4

The number and percentage of outliers excluded from the data per farm and node type.

	Farm 1		Farm 2		Farm 3	
	Outliers (N)	Outliers (%)	Outliers (N)	Outliers (%)	Outliers (N)	Outliers (%)
N1	281,285	12.07	232,849	11.48	218,202	10.05
N2	731	0.01	674	0.012	695	0.01
N3	210	0.17	1131	0.39	1615	0.48
N4					13,391	2.53
N5	24	0.00	30	0.00	5	0.00
N6	31	0.00	0	0.00	0	0.00
N9	241	0.08	210	0.07	27	0.01

Table 5

Correlations between different barn sensors of the same type. If more than two correlations were calculated (which was the case if there were more than two sensor nodes), the range from lowest to highest correlation coefficient is shown. “Max. p” indicates the maximum obtained p-value across all correlations between sensors of the same type (spearman correlation with Fisher’s z-transformation). THI = temperature-humidity index, BGHI = black globe humidity index, VWC = volumetric water content.

Node	Parameter	Farm 1			Farm 2			Farm 3		
		Mean r_s	Range r_s	Max p	Mean r_s	Range r_s	Max p	Mean r_s	Range r_s	Max p
N1	Ambient temperature	0.97	0.40–1.00	<0.001	0.97	0.25 – 1.00	<0.001	0.99	0.98 – 1.00	<0.001
N1	Relative humidity	0.95	0.87 – 0.99	<0.001	0.94	0.77 – 0.99	<0.001	0.88	0.18 – 0.98	<0.001
N1	Light intensity	0.89	0.81 – 0.95	<0.001	0.90	0.82 – 0.98	<0.001	0.93	0.87 – 0.98	<0.001
N1	THI	0.99	0.96–1.00	<0.001	1.00	0.98 – 1.00	<0.001	0.99	0.97 – 1.00	<0.001
N1	Black globe temperature	0.99	0.99 – 1.00	<0.001	1.00	1.00	<0.001	1.00	0.99 – 1.00	<0.001
N1	BGHI	0.99	0.99 – 1.00	<0.001	1.00	0.99 – 1.00	<0.001	1.00	0.99 – 1.00	<0.001
N3	Drink water temperature				0.81		<0.001	0.64	0.35 – 0.89	<0.001
N3	Drink water use							0.36	0.19 – 0.51	<0.001
N4	Litter conductivity							0.21	–0.09 – 0.76	<0.001
N4	Litter humidity							–0.18	–0.58 – 0.19	<0.001
N4	Litter temperature							0.81	0.66 – 0.91	<0.001
N4	Litter VWC							0.29	–0.29 – 0.67	<0.001
N5	CO ₂	0.78		<0.001	0.84		<0.001	0.72		<0.001
N5	H ₂ S*									
N5	NH ₃	0.60		<0.001	0.64		<0.001	0.48		<0.001
N5	Sound	0.94		<0.001	0.67		<0.001	0.92		<0.001
N6	Wind direction	0.15	0.07 – 0.22	<0.001	0.10	0.06	<0.001	0.13	–0.33 – 0.34	<0.001
N6	Wind speed	0.68	0.26 – 0.85	<0.001	0.75	0.24	<0.001	0.66	0.52 – 0.77	<0.001

* No correlations are displayed for H₂S because only values of 0 were recorded for this parameter.

type, which gives an indication of the variation in a certain parameter across a barn and may help to determine the number of sensors required for obtaining a good representation of an entire barn. These correlations were not performed on the N2 nodes because for determining individual cow welfare it is necessary to measure the behaviour of individual cows. Table 5 shows that the correlations are very high for the measures collected by the N1 nodes, showing that the climate is relatively homogeneous within each of the monitored barn sections. An exception to this conclusion is humidity, which may indicate that some areas of the barn (e.g., close to sprinklers) may be more humid than others. However, the differences may also be due partly to difficulties with the humidity sensors (as detailed in Section 3.3). In contrast to those for N1 nodes, measures of air quality, wind, litter and drink water have much lower inter-sensor correlations. Some of this variation might on some occasions be the result of problems with individual sensors. Specifically, from April 2022 the NH₃ measurements by one N5 sensor at farm 3 seemed to have “drifted” and suggest that the sensor needs recalibrating. Also, problems with cows digging out the (N4) litter sensors may have affected the measurements of these sensors. However, apart from these specific effects, most of the variation between sensors is likely due to the variability in the conditions in each monitored barn section. Consequently, for these parameters it is important to obtain measures from different areas across the barn. Interestingly, the degree of variation does not seem to depend on the size of the monitored areas, because the variation in the smallest area (farm 3; 920 m²) was similar to that of the largest area (farm 2; 1324 m²). Therefore, the characteristics of the barn structure, its orientation, and characteristics of the environment surrounding the barn may be more important than the size of the barn in determining the homogeneity of the barn environment. It must also be noted that, although variation across the barn was small for some climate measures, such as temperature and THI, the relative importance of these measures on cow welfare warrants the use of multiple sensors to accurately determine the climatic conditions in different areas of the barn. The decision on the number of sensors per parameter that should be installed should therefore be based on a careful consideration of the costs and benefits.

3.5. Potential diagnostics with the output

The combination of the data obtained from the integrated monitoring system can enable different types of analyses for cow welfare

assessment. On a basic level, the values of individually measured parameters can be used to detect situations of reduced welfare, e.g., increased daily lying time as an indication of lameness (Dittrich et al., 2019; Tucker et al., 2021). However, because an integrated system can measure simultaneously many different parameters that are relevant to cow welfare, such a system can potentially detect many different types of causes of reduced welfare (including lameness, mastitis and heat stress), provided that relevant indicators are measured (Leliveld and Provolo, 2020). This feature provides advantages over systems that only measure a single or only a few parameters, because an integrated system reduces the need to install multiple systems, each with its own architecture and supporting software (and thereby reducing the costs of purchase and installation). However, even better insight into a cow’s welfare status can be obtained by combining different simultaneous measurements (Frost et al., 1997; Leliveld and Provolo, 2020; Wisniewski et al., 2019). Fig. 6a illustrates the benefits of combining different measurements of behaviour. In this graph of a single cow’s behaviour, an increase in the time spent lying down and decrease in the time spent standing (and later also eating) can be seen from around a week before to two weeks after the cow was diagnosed with fever. Because an increase in the time spent exhibiting one type of behaviour signifies a reduction in the time spent in other types of behaviour, monitoring whether the increase in lying time affects the time spent in another behaviour (e.g., eating), may help to better assess the health status of the cow and provide better treatment.

Even more insight can be obtained when behavioural data are combined with data regarding the barn climate, as is illustrated in Fig. 6b. In this figure a change in the behaviour of a single cow can be seen, i.e., a decrease in lying behaviour and increase in standing behaviour. A reduction in lying time and an increase in standing time could be a sign of heat stress (Hoffmann et al., 2020; Tucker et al., 2021), but may also be observed in cows with mastitis (Dittrich et al., 2019; Tucker et al., 2021). The inclusion of THI measurements improves the determination of the reason for this change in behaviour. In the case illustrated by Fig. 6b, the change in lying and standing time seem to parallel simultaneous changes in THI, suggesting that the cow may be experiencing heat stress, rather than suffering from mastitis.

The integration of data, as performed in this prototype system, not only benefits the monitoring of the welfare status of individual cows, but also could help to identify structural or mechanical problems in the barn that could affect the welfare of all cows. This is enabled by the use of an

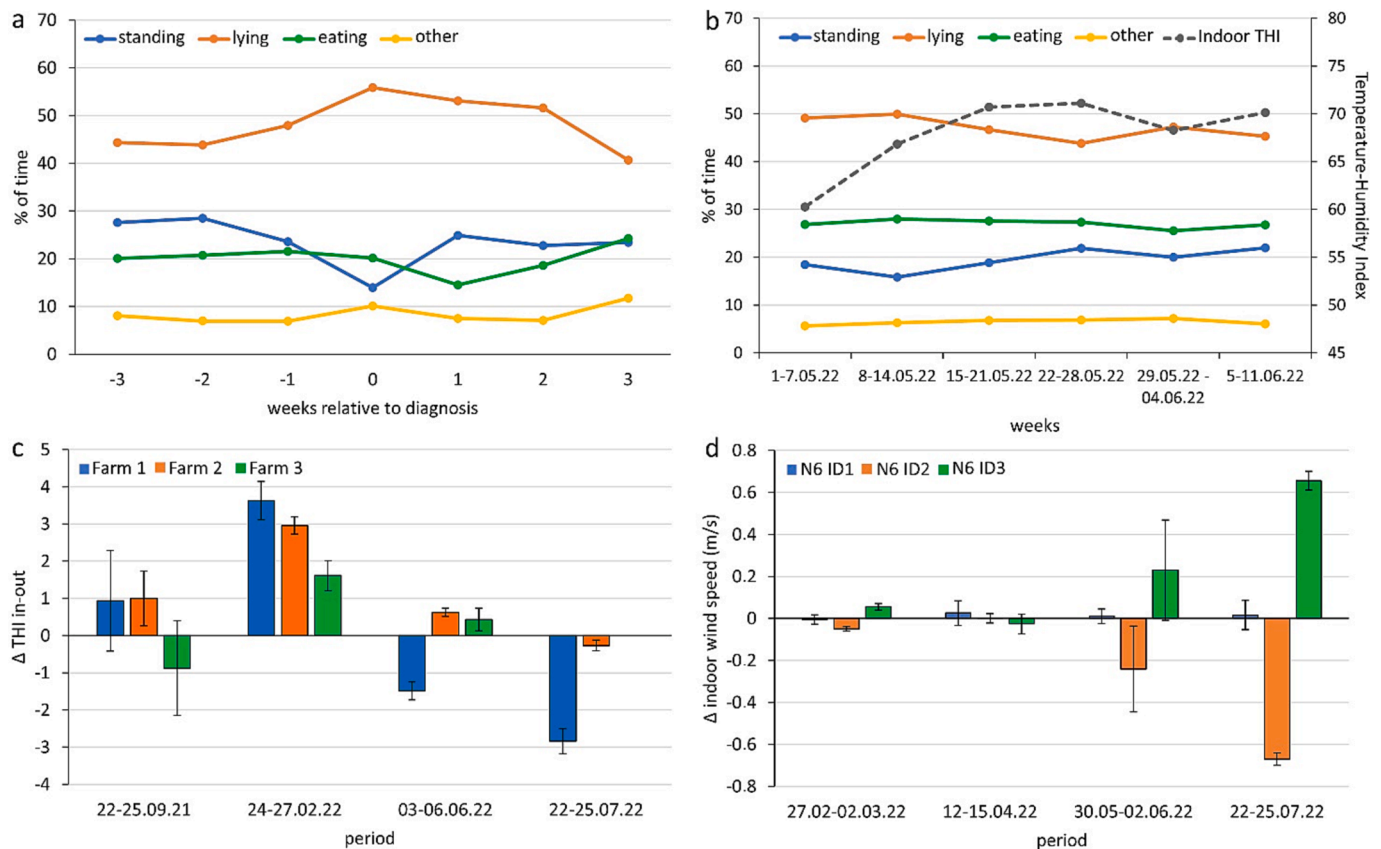

Fig. 6. Examples of diagnostics that could be performed with the collected data from the integrated monitoring system. a) The percentage of time spent in different behaviours by a single cow in the weeks before and after a diagnosed health issue (fever in this case), with 0 indicating the day of diagnosis. b) The percentage of time spent in different behaviours by a single cow during several weeks in late spring, combined with the mean THI (temperature-humidity index) during these weeks. c) Daily means and standard deviations of the difference between indoor and outdoor THI, calculated by subtracting outdoor from indoor values, on the three farms. The means are based on four selected days per season: 22–25.09.2021 (autumn), 24–27.02.2022 (winter), 03–06–06.2022 (spring), 22–25.07.2022 (summer). d) Daily means and standard deviations of the wind speed measured by three sensors that were placed in different locations in the barn of farm 1. The values are presented as differences from the mean of all sensors and are based on four selected days per season: 22–25.09.2021 (autumn), 24–27.02.2022 (winter), 03–06–06.2022 (spring), 22–25.07.2022 (summer).

external weather station as a reference and the use of multiple sensors to measure the same parameters. As illustrated in Fig. 6c, the combination of measures of temperature and humidity both inside and outside the barn allows to calculate the difference in THI between the inside and outside of the barn and thereby to determine if the structure functions well to buffer extreme external weather conditions (Lovarelli et al., 2021). Fig. 6c shows that the more enclosed barn at farm 1 has positive Δ THI values in February and negative Δ THI values in June and July, suggesting that this barn buffers the outside THI values (at least numerically) better than the barn on the other two farms, which are open on all sides. This example shows that the integrated system can monitor the buffering capabilities of a barn and potential changes to them over time, which might occur when, for instance, climate controlling devices such as ventilators malfunction. The automatic detection of changes in the barn climate would enable a farmer to respond before any effect may be noticed in the behaviour of the cows.

In addition, the use of multiple sensors to measure the same parameter offers the possibility to detect specific potential problem areas where the environmental conditions are inferior to those elsewhere in the barn. For example, Fig. 6d illustrates a comparison of wind speed measured by three wind sensors on farm 1 in different seasons. During autumn and winter, the values measured by the different sensors seem quite similar, but during late spring and summer (when the ventilators were operational), the mean values measured by sensor 2 are numerically lower than those from the other two sensors, and the mean values measured by sensor 3 are numerically higher than the average

wind speed in the barn. Although these results may in part have been caused by a slightly higher positioning of sensor 2, this comparison also suggests that the ventilation system has a better coverage of the feeding area (monitored by sensor 3) than of the lying area (monitored by sensors 1 and 2), which could negatively affect cows' lying times in the summer period (Calegari et al., 2014). The detection of problem areas in the barn can help to resolve potential structural or mechanical problems in these areas, thereby improving the barn environment as a whole and preventing the aggregation of cattle in one part of the barn (Provolo and Riva, 2009; Seyfi, 2013). The integrated monitoring system can also be extended to directly control the barn environment through the operation of, for example, cooling systems and wind screens, thereby achieving faster and more appropriate barn climate control.

4. Discussion

The prototype of an integrated system designed to monitor barn environment and cow behaviour simultaneously was aimed to provide an open framework for research, allowing for customization and fine-tuning before its ultimate adoption as a management assistant on commercial dairy farms. Evaluation of the collected data shows that the system can effectively handle large quantities of information arriving at frequent intervals, with minimal data loss and outliers. Indeed, even though there were occasional malfunctions of individual nodes or sensors, the functioning of the more central components (i.e., gateways and backend) were only affected when power outages occurred on the farms.

Data loss was kept low by combining a time-slotted wireless protocol, which prevents data collision (Khaleghi et al., 2013), with distributed data buffering, which minimizes data loss due to temporary failures of the communication infrastructure. Furthermore, the time of the nodes was constantly synchronized with the gateway time to prevent clock drifting which could have caused loss of data if the data were transmitted in the wrong time slot.

Another challenge for data fusion (or indeed for any automatic collection of data) is the inherent uncertainty in sensor measurements, which could be caused by noise or impreciseness of the measurements or by the ambiguities and inconsistencies present in the environment (King et al., 2017; Kumar et al., 2006). Indeed, even though the percentage of outliers in our data was low, the outliers still had considerable effects on the calculated means and should therefore be excluded from analyses. In this study, the data were filtered manually, but there are several established outlier-detection algorithms that could be integrated in the system to exclude these values automatically (Basu and Meckesheimer, 2007; Du et al., 2023). The evaluation of data stability and outliers represent the first steps in testing the quality (or reliability) of the data that are obtained by the integrated system. The next step is to test the system's ability to accurately detect situations of reduced cow welfare on the farm.

Apart from the data quality, the cost of the system (purchase, installation, and operation) is also of high importance to farmers (Zhang et al., 2021). The initial investment is expected to lie between €60,000–80,000 for a farm with 200 dairy cows. Although initial investments in automatic monitoring system are usually high, many economic evaluations show that these systems increase annual profit (Adenuga et al., 2020; Drach et al., 2017; Rutten et al., 2014). For instance, improved oestrus detection through the monitoring of cow behaviour was estimated to raise annual profit by 7 to 94.3% (Adenuga et al., 2020), while effective heat stress management could reduce economic loss due to heat stress by as much as 60% (St-Pierre et al., 2003). Compared to other systems, which tend to focus on a limited set of parameters, this integrated system has the added advantage of enabling improved management of multiple variables rather than just one (e.g., oestrus detection or heat stress management), facilitating higher net profits. Nevertheless, the initial installation cost plays an important role in the decision of farmers to invest in PLF technologies (Borchers and Bewley, 2015). To reduce costs, it is important to limit the use of multiple sensors by determining the minimum required number of sensors that are necessary per barn. The correlations shown in Table 5 can help to determine this number.

To obtain a comprehensive overview of all aspects of a cow's state, especially related to welfare (Fraser et al., 1997; von Keyserlingk et al., 2009), a multidimensional approach is needed. Advantages of using integrated data from different sources have already been shown in several studies on livestock management (Chang et al., 2022; Cruz et al., 2022; Pandey et al., 2021). However, while it is certain that data integration gives a better overview of a cow's status, much is still unknown about the interactions between barn environment, cow behaviour and cow status (Leliveld & Provolo, 2020). For research and development purposes, it is therefore important that a system is open and can be customized to incorporate new measurements and explore new approaches to optimize the automatic monitoring of dairy cows. The present study lays the foundation of an integrated automatic monitoring system that is customizable and open by establishing suitable architecture that can unify and process in one place data from various sources. In addition, the system incorporates features that are specifically adapted for the use on dairy farms and in rural areas, such as an ultra-low power design and wireless communication channels (Germani et al., 2019; Riaboff et al., 2022).

This work aimed to establish an open and customizable system with an architecture suited to data integration. By establishing such a system, this work provides an open framework for research-based data integration appropriate for the automatic, remote, and real-time monitoring

of livestock. The next step in the development of this system is to design models and algorithms that can combine the many different parameters that are measured by the system to detect patterns associated with single welfare issues (e.g., reduced lying time, combined with increased THI as an indication of heat stress) as well as reduced cow welfare in general. For instance, algorithms similar to those developed by Chang et al. (2022) could be adopted to detect various cow welfare issues from the data generated by this system. Another important next step is the integration of herd data (e.g., calving dates and health status) and milk yield. This would not only help to improve the accurate detection of single welfare issues (Jensen et al., 2016; Van Herthem et al., 2016), but also provide important information on cow reproduction and production, leading to a more complete picture of a cow's state and improved cow management.

5. Conclusions

The development of this prototype system entails important progress towards data integration in the field of smart dairy farming, as well as a first step in the design and implementation of an open and customizable automatic integrated cow monitoring system for both research and commercial purposes. Next steps involve the integration of additional information, such as herd data, and to develop suitable models and algorithms that can combine data from multiple diverse sources to provide an accurate and complete overview of the state of an animal. The final product would then consist of a single system that automatically monitors all aspects related to production, reproduction, and welfare of cows on the farm, thereby supporting farmers in important management decision-making.

CRedit authorship contribution statement

Lisette M.C. Leliveld: Methodology, Investigation, Formal analysis, Visualization, Writing – original draft, Writing – review & editing. **Carlo Brandolese:** Conceptualization, Methodology, Software, Writing – original draft, Visualization, Writing – review & editing. **Matteo Grotto:** Methodology, Software, Data curation. **Augusto Marinucci:** Resources. **Nicola Fossati:** Resources. **Daniela Lovarelli:** Methodology, Investigation, Formal analysis, Writing – review & editing. **Elisabetta Riva:** Investigation. **Giorgio Provolo:** Conceptualization, Methodology, Data curation, Investigation, Funding acquisition, Visualization, Writing – review & editing.

Declaration of competing interest

The authors declare that they have no known competing financial interests or personal relationships that could have appeared to influence the work reported in this paper.

Data availability

Data will be made available on request.

Acknowledgements

This project was funded by the Lombardy Region, Italy, as part of the Rural Development Program 2014–2020, EIP-AGRI Operational Groups, Project GALA, and was carried out within the Agritech National Research Center and received funding from the European Union Next-GenerationEU, Belgium, (PIANO NAZIONALE DI RIPRESA E RESILIENZA (PNRR) – MISSIONE 4 COMPONENTE 2, INVESTIMENTO 1.4 – D.D. 1032 17/06/2022, CN00000022). This manuscript reflects only the authors' views and opinions, neither the European Union nor the European Commission can be considered responsible for them. The authors would like to thank the farmers and their staff for their support in the installation and operation of the monitoring system on their farms, as

well as for providing cow-related data. Furthermore, the authors like to thank Paolo Marconi and Lucio Zanini of the Regional Association of Farmers in Lombardy (ARAL) and Alon Arazi of Afimilk® for providing data on the health events of cows at the three commercial farms. Simone Libutti is also thanked for his work on the development of the dashboard. Finally, the authors would like to thank Arianna Panara and Manuela Dall'Angelo for technical support in the behavioural data collection and Tomaso Bertoni and Stefano Penati for technical support in the maintenance of the system.

Appendix A. Supplementary data

Supplementary data to this article can be found online at <https://doi.org/10.1016/j.compag.2023.108499>.

References

- Abeni, F., Petrerà, F., Galli, A., 2019. A survey of Italian dairy farmers' propensity for precision livestock farming tools. *Animals* 9, 1–13. <https://doi.org/10.3390/ani9050202>.
- Adenuga, A.H., Jack, C., Olagunju, K.O., Ashfield, A., 2020. Economic viability of adoption of automated oestrus detection technologies on dairy farms: A review. *Animals* 10, 1–14. <https://doi.org/10.3390/ani10071241>.
- Akbar, M.O., Shahbaz Khan, M.S., Ali, M.J., Hussain, A., Qaiser, G., Pasha, M., Pasha, U., Missen, M.S., Akhtar, N., 2020. IoT for Development of Smart Dairy Farming. *Journal of Food Quality* 2020, 4242805. <https://doi.org/10.1155/2020/4242805>.
- Alonso, R.S., Sittón-Candanedo, I., García, Ó., Prieto, J., Rodríguez-González, S., 2020. An Intelligent Edge-IoT Platform for Monitoring Livestock and Crops in a Dairy Farming Scenario. *Ad Hoc Netw.* 98, 102047. <https://doi.org/10.1016/j.adhoc.2019.102047>.
- Amiri-Zarandi, M., Fard, M.H., Yousefinaghani, S., Kaviani, M., Dara, R., 2022. A Platform Approach to Smart Farm Information Processing. *Agriculture* 12, 838. <https://doi.org/10.3390/agriculture12060838>.
- Barkema, H.W., von Keyserlingk, M.A.G., Kastelic, J.P., Lam, T.J.G.M., Luby, C., Roy, J. P., LeBlanc, S.J., Keefe, G.P., Kelton, D.F., 2015. Invited review: Changes in the dairy industry affecting dairy cattle health and welfare. *J. Dairy Sci.* 98, 7426–7445. <https://doi.org/10.3168/jds.2015.9377>.
- Basu, S., Meckesheimer, M., 2007. Automatic outlier detection for time series: An application to sensor data. *Knowl. Inf. Syst.* 11, 137–154. <https://doi.org/10.1007/s10115-006-0026-6>.
- Berckmans, D., 2014. Precision livestock farming technologies for welfare management in intensive livestock systems. *Rev. Sci. Tech.* 33, 189–196. <https://doi.org/10.20506/rst.33.1.2273>.
- Berckmans, D., 2017. General introduction to precision livestock farming. *Anim. Front.* 7, 6–11. <https://doi.org/10.2527/af.2017.0102>.
- Bluetooth, S.I.G., 2023. Specifications. Accessed on 5 Octobre 2023. <https://www.bluetooth.com/specifications/>.
- Borchers, M.R., Bewley, J.M., 2015. An assessment of producer precision dairy farming technology use, prepurchase considerations, and usefulness. *J. Dairy Sci.* 98, 4198–4205. <https://doi.org/10.3168/jds.2014-8963>.
- Calegari, F., Calamari, L., Frazzi, E., 2014. Fan cooling of the resting area in a free stalls dairy barn. *Int. J. Biometeorol.* 58, 1225–1236. <https://doi.org/10.1007/s00484-013-0716-1>.
- Chang, A. Z., Swain, D. L., Trotter, M. G., 2022. A multi-sensor approach to calving detection. *Inf. Process. Agric.* <https://doi.org/10.1016/j.inpa.2022.07.002>.
- Cruz, V., Rico, J., Coelho, D., Baptista, F., 2022. Innovative PLF Tool to Assess Growing-Finishing Pigs' Welfare. *Agronomy* 12, 2159. <https://doi.org/10.3390/agronomy12092159>.
- De Montis, A., Modica, G., Arcidiacono, C., 2017. Aginformatics. In: Schintler, L.A., McNeely, C.L. (Eds.), *Encyclopedia of Big Data*. Springer International Publishing, Cham, pp. 1–4. https://doi.org/10.1007/978-3-319-32001-4_218-1.
- Dittrich, I., Gertz, M., Krieter, J., 2019. Alterations in sick dairy cows' daily behavioural patterns. *Heliyon* 5, e02902.
- Dolecheck, K.A., Silvia, W.J., Heersche, G., Chang, Y.M., Ray, D.L., Stone, A.E., Wadsworth, B.A., Bewley, J.M., 2015. Behavioral and physiological changes around estrus events identified using multiple automated monitoring technologies. *J. Dairy Sci.* 98, 8723–8731. <https://doi.org/10.3168/jds.2015-9645>.
- Dominiak, K.N., Kristensen, A.R., 2017. Prioritizing alarms from sensor-based detection models in livestock production - A review on model performance and alarm reducing methods. *Comp. Electron. Agric.* 133, 46–67. <https://doi.org/10.1016/j.compag.2016.12.008>.
- Drach, U., Halachmi, I., Pnini, T., Izhaki, I., Degani, A., 2017. Automatic herding reduces labour and increases milking frequency in robotic milking. *Biosyst. Eng.* 155, 134–141. <https://doi.org/10.1016/j.biosystemseng.2016.12.010>.
- Du, X., Zuo, E., Chu, Z., He, Z., Yu, J., 2023. Fluctuation-Based Outlier Detection. *Sci. Rep.* 13, 1–18. <https://doi.org/10.1038/s41598-023-29549-1>.
- Firner, B., Xu, C., Howard, R., Zhang, Y., 2010. In: *Multiple Receiver Strategies for Minimizing Packet Loss in Dense Sensor Networks*. ACM Press, Chicago, Illinois, USA, p. 211. <https://doi.org/10.1145/1860093.1860122>.
- Fountas, S., Espejo-Garcia, B., Kasimati, A., Mylonas, N., Darra, N., 2020. The Future of Digital Agriculture: Technologies and Opportunities. *IT Prof.* 22, 24–28. <https://doi.org/10.1109/MITP.2019.2963412>.
- Fraser, D., Weary, D.M., Pajor, E.A., Milligan, B.N., 1997. A scientific conception of animal welfare that reflects ethical concerns. *Anim. Welf.* 6, 187–205. <https://doi.org/10.1017/S0962728600019795>.
- Frost, A.R., Schofield, C.P., Beaulah, S.A., Mottram, T.T., Lines, J.A., Wathes, C.M., 1997. A review of livestock monitoring and the need for integrated systems. *Comp. Electron. Agric.* 17, 139–159. [https://doi.org/10.1016/s0168-1699\(96\)01301-4](https://doi.org/10.1016/s0168-1699(96)01301-4).
- Germani, L., Mecarelli, V., Baruffa, G., Rugini, L., Frescura, F., 2019. An IoT architecture for continuous livestock monitoring using lora LPWAN. *Electronics* 8, 1435. <https://doi.org/10.3390/electronics8121435>.
- Halachmi, I., Guarino, M., Bewley, J., Pastell, M., 2019. Smart Animal Agriculture: Application of Real-Time Sensors to Improve Animal Well-Being and Production. *Annu. Rev. Anim. Biosci.* 7, 403–425. <https://doi.org/10.1146/annurev-animal-020518-114851>.
- Hoffmann, G., Herbut, P., Pinto, S., Heinicke, J., Kuhla, B., Amon, T., 2020. Animal-related, non-invasive indicators for determining heat stress in dairy cows. *Biosyst. Eng.* 199, 83–96. <https://doi.org/10.1016/j.biosystemseng.2019.10.017>.
- Jacobs, J.A., Siegford, J.M., 2012. Invited review: The impact of automatic milking systems on dairy cow management, behavior, health, and welfare. *J. Dairy Sci.* 95, 2227–2247. <https://doi.org/10.3168/jds.2011-4943>.
- Jensen, D.B., Hogeveen, H., De Vries, A., 2016. Bayesian integration of sensor information and a multivariate dynamic linear model for prediction of dairy cow mastitis. *J. Dairy Sci.* 99, 7344–7361. <https://doi.org/10.3168/jds.2015-10060>.
- Khaleghi, B., Khamis, A., Karray, F.O., Razavi, S.N., 2013. Multisensor data fusion: A review of the state-of-the-art. *Inf. Fusion* 14, 28–44. <https://doi.org/10.1016/j.inffus.2011.08.001>.
- King, R.C., Villeneuve, E., White, R.J., Sherratt, R.S., Holderbaum, W., Harwin, W.S., 2017. Application of data fusion techniques and technologies for wearable health monitoring. *Med. Eng. Phys.* 42, 1–12. <https://doi.org/10.1016/j.medengphy.2016.12.011>.
- Kumar, M., Garg, D. P., & Zachery, R. A., 2006. A generalized approach for inconsistency detection in data fusion from multiple sensors. In *Proceedings of the 2006 American Control Conference*, Minneapolis, MN, USA, 14–16 June 2006.
- Lee, M., Seo, S., 2021. Wearable wireless biosensor technology for monitoring cattle: A review. *Animals* 11, 2779. <https://doi.org/10.3390/ani11102779>.
- Leliveld, L.M.C., Provolo, G., 2020. A Review of Welfare Indicators of Indoor-Housed Dairy Cow as a Basis for Integrated Automatic Welfare Assessment Systems. *Animals* 10, 1430. <https://doi.org/10.3390/ani10081430>.
- Lovarelli, D., Riva, E., Mattachini, G., Guarino, M., Provolo, G., 2021. Assessing the effect of barns structures and environmental conditions in dairy cattle farms monitored in Northern Italy. *J. Agr. Eng. Li I*, 1229. <https://doi.org/10.4081/jae.2021.1229>.
- Lovarelli, D., Brandolese, C., Leliveld, L., Finzi, A., Riva, E., Grotto, M., Provolo, G., 2022. Development of a new wearable 3D sensor node and innovative open classification system for dairy cows' behavior. *Animals* 12, 1447. <https://doi.org/10.3390/ani12111447>.
- Norton, T., Chen, C., Larsen, M.L.V., Berckmans, D., 2019. Review: Precision livestock farming: building 'digital representations' to bring the animals closer to the farmer. *Animal* 13, 3009–3017. <https://doi.org/10.1017/S175173111900199X>.
- Oasis, 2023. MQTT Specifications. Accessed on 05 Octobre 2023. <https://mqtt.org/mqtt-specification/>.
- Pandey, S., Kalwa, U., Kong, T., Guo, B., Gauger, P.C., Peters, D.J., Yoon, K.-Y., 2021. Behavioral Monitoring Tool for Pig Farmers: Ear Tag Sensors, Machine Intelligence, and Technology Adoption Roadmap. *Animals* 11, 2665. <https://doi.org/10.3390/ani11092665>.
- Provolo, G., Riva, E., 2009. One Year Study of Lying and Standing Behaviour of Dairy Cows in a Freestall Barn in Italy. *Agric. Eng.* 2, 27–33. <https://doi.org/10.4081/jae.2009.2.27>.
- Riaboff, L., Shalloo, L., Smeaton, A.F., Couvreur, S., Madouasse, A., Keane, M.T., 2022. Predicting livestock behaviour using accelerometers: A systematic review of processing techniques for ruminant behaviour prediction from raw accelerometer data. *Comp. Electron. Agric.* 192, 106610. <https://doi.org/10.1016/j.compag.2021.106610>.
- Rushen, J., de Passillé, A.M., von Keyserlingk, M.A.G., Weary, D.M., 2008. *The welfare of cattle*. Springer, Dordrecht, The Netherlands.
- Rutten, C.J., Velthuis, A.G.J., Steeneveld, W., Hogeveen, H., 2013. Invited review: Sensors to support health management on dairy farms. *J. Dairy Sci.* 96, 1928–1952. <https://doi.org/10.3168/jds.2012-6107>.
- Rutten, C.J., Steeneveld, W., Inchaisri, C., Hogeveen, H., 2014. An ex ante analysis on the use of activity meters for automated estrus detection: To invest or not to invest? *J. Dairy Sci.* 97, 6869–6887. <https://doi.org/10.3168/jds.2014-7948>.
- Saint-Dizier, M., Chastant-Maillard, S., 2012. Towards an Automated Detection of Oestrus in Dairy Cattle. *Reprod. Domest. Anim.* 47, 1056–1061. <https://doi.org/10.1111/j.1439-0531.2011.01971.x>.
- Schauberger, G., Hennig-Pauka, I., Zollitsch, W., Hörtenhuber, S.J., Baumgartner, J., Niebuhr, K., Piringer, M., Knauder, W., Anders, I., Andre, K., Schönhart, M., 2020. Efficacy of adaptation measures to alleviate heat stress in confined livestock buildings in temperate climate zones. *Biosyst. Eng.* 200, 157–175. <https://doi.org/10.1016/j.biosystemseng.2020.09.010>.
- Seyfi, S.U., 2013. Hourly and seasonal variations in the area preferences of dairy cows in freestall housing. *J. Dairy Sci.* 96, 906–917. <https://doi.org/10.3168/jds.2012-5618>.
- Smart Farm Information Processing. *Agriculture*, 12, 838. <https://doi.org/10.3390/agriculture12060838>.

- St-Pierre, N.R., Cobanov, B., Schnitkey, G., 2003. Economic Losses from Heat Stress by US Livestock Industries. *J. Dairy Sci.* 86, E52–E77. [https://doi.org/10.3168/jds.S0022-0302\(03\)74040-5](https://doi.org/10.3168/jds.S0022-0302(03)74040-5).
- Symeonaki, E., Arvanitis, K.G., Piromalis, D., Tseles, D., Balafoutis, A.T., 2022. Ontology-Based IoT Middleware Approach for Smart Livestock Farming toward Agriculture 4.0: A Case Study for Controlling Thermal Environment in a Pig Facility. *Agronomy* 12, 750. <https://doi.org/10.3390/agronomy12030750>.
- Tucker, C.B., Jensen, M.B., de Passillé, A.M., Hänninen, L., Rushen, J., 2021. Invited review: Lying time and the welfare of dairy cows. *J. Dairy Sci.* 104, 20–46. <https://doi.org/10.3168/jds.2019-18074>.
- Van Herthem, T., Bahr, C., Tello, A.S., Viazzi, S., Steensels, M., Romanini, C.E.B., Lokhorst, C., Maltz, E., Halachmi, I., Berckmans, D., 2016. Lameness detection in dairy cattle: Single predictor v. multivariate analysis of image-based posture processing and behaviour and performance sensing. *Animal* 10, 1525–1532. <https://doi.org/10.1017/S1751731115001457>.
- von Keyserlingk, M.A.G., Rushen, J., de Passillé, A.M., Weary, D.M., 2009. Invited review: The welfare of dairy cattle—key concepts and the role of science. *J. Dairy Sci.* 92, 4101–4111. <https://doi.org/10.3168/jds.2009-2326>.
- Wathes, C.M., 2010. The prospects for precision livestock farming. *J. Roy. Agric. Soc. England* 171, 26–32.
- Wisniewski, L., Norby, B., Pierce, S.J., Becker, T., Sordillo, L.M., 2019. Prospects for predictive modeling of transition cow diseases. *Anim. Health Res. Rev.* 20, 19–30. <https://doi.org/10.1017/S1466252319000112>.
- Zhang, M., Wang, X., Feng, H., Huang, Q., Xiao, X., Zhang, X., 2021. Wearable Internet of Things enabled precision livestock farming in smart farms: A review of technical solutions for precise perception, biocompatibility, and sustainability monitoring. *J. Clean. Prod.* 312, 127712 <https://doi.org/10.1016/j.jclepro.2021.127712>.