

# TITLE PAGE

## Citation Format:

F. Negretti, C. Amendola, S. Brigadoi, M. Buttafava, R. J. Cooper, C. D. Man, T. Durduran, F. Faure, M. Fornasier, A. Galderisi, M. Lacerenza, H. Marchiori, A. Scarpa, L. Spinelli, A. Torricelli, and D. Contini, "PROMETEUS: Hybrid TD-NIRS and SCOS Instrument for Real-Time Monitoring of Brain Metabolism in Preterm Neonates – System Architecture and Characterization," in *European Conferences on Biomedical Optics 2025*, Technical Digest Series (Optica Publishing Group, 2025), paper M1B.2.

## Abstract link:

<https://opg.optica.org/abstract.cfm?uri=ECBO-2025-M1B.2>

# PROMETEUS: Hybrid TD-NIRS and SCOS Instrument for Real-Time Monitoring of Brain Metabolism in Preterm Neonates - System Architecture and Characterization

Fabio Negretti,<sup>1,\*</sup> Caterina Amendola,<sup>1</sup> Sabrina Brigadoi,<sup>2</sup> Mauro Buttafava,<sup>3</sup> Robert J. Cooper,<sup>4</sup> Chiara Dalla Man,<sup>5</sup> Turgut Durduran,<sup>6,7</sup> Flora Faure,<sup>4</sup> Mirko Fornasier,<sup>6</sup> Alfonso Galderisi,<sup>8</sup> Michele Lacerenza,<sup>3</sup> Hadija Marchiori,<sup>5</sup> Alberto Scarpa,<sup>9</sup> Lorenzo Spinelli,<sup>10</sup> Alessandro Torricelli,<sup>1,10</sup> and Davide Conti<sup>1</sup>

<sup>1</sup> Dipartimento di Fisica, Politecnico di Milano, Piazza Leonardo da Vinci 32, Milano 20133, Italy

<sup>2</sup> Department of Developmental and Social Psychology, University of Padua, Padua, Italy

<sup>3</sup> PIONIRS S.r.l., via Timavo 24, 20124 Milan, Italy

<sup>4</sup> DOT- HUB, Department of Medical Physics and Biomedical Engineering, University College London, London, United Kingdom

<sup>5</sup> Department of Information Engineering, University of Padua, Padua, Italy

<sup>6</sup> ICFO - Institut de Ciències Fotòniques, The Barcelona Institute of Science and Technology, 08860 Castelldefels (Barcelona), Spain

<sup>7</sup> Institució Catalana de Recerca i Estudis Avançats (ICREA), Barcelona, Spain

<sup>8</sup> Department of Pediatrics, Yale University, New Haven, CT, USA

<sup>9</sup> Dave S.r.l., via Talponedo, 29/A, 33080 Porcia (PN), Italy

<sup>10</sup> Istituto di Fotonica e Nanotecnologie, Consiglio Nazionale delle Ricerche, Piazza Leonardo da Vinci 32, Milano 20133, Italy

\*fabio.negretti@polimi.it

**Abstract:** Prometeus project aims at enabling personalized nutrition in preterm neonates: by combining a hybrid diffuse optics metabolic sensing system with metabolic modeling, it optimizes brain health, reducing prematurity-related disabilities and enhancing NICU care. © 2025 The Author(s)

## 1. Prometeus project

The brain of a preterm infant is highly vulnerable to early neonatal injuries, which significantly increase the risk of neurodevelopmental disabilities. Proper brain development and growth depend on an adequate supply of nutrients and oxygen. However, current nutritional strategies are based on predefined, non-personalized charts and lack real-time monitoring of both brain health and metabolic needs. As a result, sudden changes in the brain's energy requirements cannot be promptly addressed through immediate adjustments in glucose and nutrient delivery, resulting in prematurity-associated disability. [1] In this framework, Horizon Pathfinder 2022 project Prometeus is

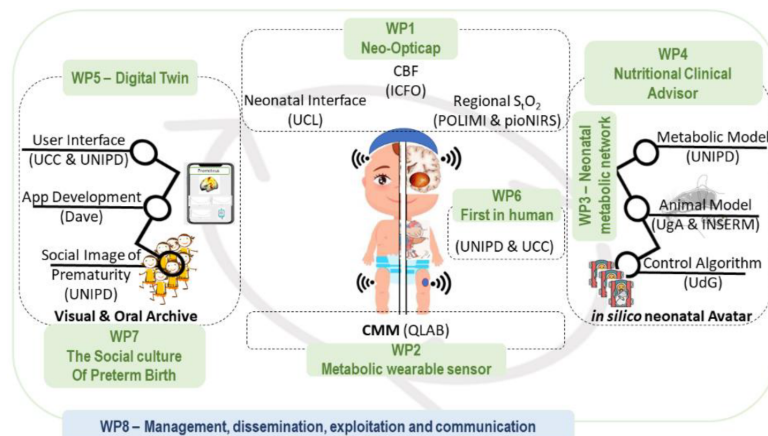

Fig. 1: Prometeus project outline and interactions between Work Packages (WPs).

introducing innovative continuous clinical monitoring techniques and tailored metabolic modelling with the final goal of real-time, ad-hoc adjustment of glucose and other key brain metabolites fundamental to the correct development of the neonatal brain. This is achieved following a multidisciplinary approach:

**I. Development of optical, non-invasive metabolic sensing:** in order to retrieve the full metabolic picture of the brain in preterm infants, in terms of the cerebral metabolic rate of oxygen  $CMRO_2$ , we resort to complementary, non-invasive diffuse optics techniques integrated within the same instrumental setup. Specifically, Time-Domain Near InfraRed Spectroscopy (TD-NIRS) is applied exploiting its depth sensitivity, capability of encoding signal depth via time of arrival and ability to decouple absorption coefficient and reduced scattering coefficient to infer on microvascular cerebral oxygen saturation  $StO_2$ . [2] On the other side, Speckle Contrast Optical Spectroscopy (SCOS) allows to observe speckle patterns fluctuations determined by red blood cells movement and determine cerebral blood flow (CBF). [3] Both techniques went through extensive development, both from the theoretical and technological viewpoints and their effectiveness in clinical scenarios has been validated in multiple previous works. [4, 5]

**II. Development of individualized metabolic models:** the physiological data provided by the cot-side diffuse optics measurements will be fed to specifically tailored metabolic models that describe the interaction between the three key brain fuels - glucose, lactate, and beta-hydroxybutyrate (BHB) - [6] and their impact on cerebral blood flow, oxygen saturation and metabolism. As a result, the model will be able to predict individualized dietary intakes based on the current state of the infant's brain.

In this work, we present the progress of the project related to the development of an optical, multimodal, non-invasive metabolic sensing device (I.), which is at the core of work package 1 (Fig.1).

## 2. System architecture

From the architectural viewpoint, the system includes a 2-wavelength (685, 830 nm), single channel NIRSBOX OEM (PIONIRS S.r.l, Milan, Italy) [7] as TD-NIRS module, providing picosecond laser pulses with maximum average power  $> 4$  mW at a 53 MHz repetition rate and a SCOS prototype device developed at ICFO, comprising a wavelength stabilized, high coherence continuous wave laser diode at 785 nm, six CMOS cameras for multi-channel speckle detection and an onboard main control unit (MCU) for internal data processing and CBF calculation.

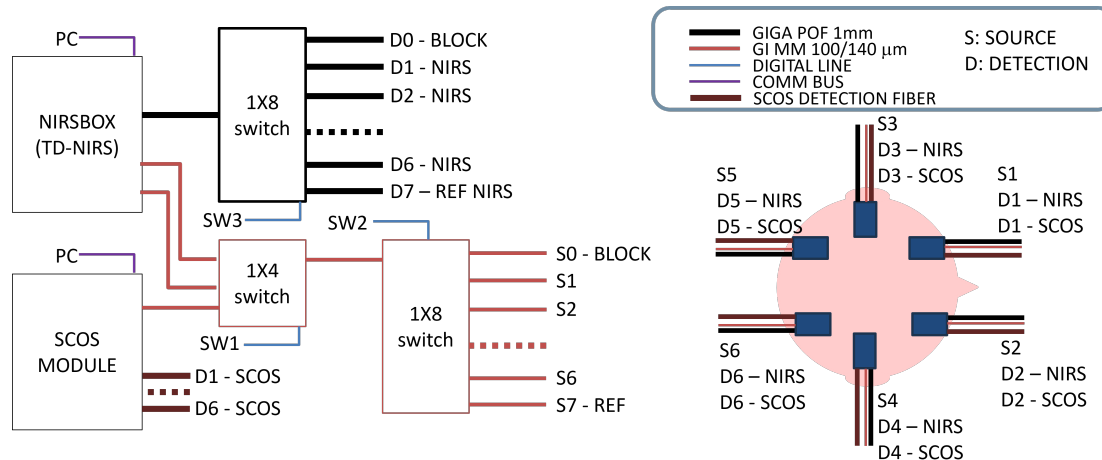

Fig. 2: Schematic of the Prometheus hybrid TD-NIRS and SCOS device for metabolic monitoring.

All laser ports of the two modules are coupled to a 1x4 fiber switch (Laser Components Germany GmbH, Olching, Germany) to allow for time multiplexing of the two measurement techniques, avoiding crosstalk between the signals. The output of the 1x4 switch is connected to a 1x8 fiber switch (Laser Components Germany GmbH) allowing to select which of six spots on the brain to sense, in sequential order. A seventh channel for reference measurements during real time monitoring is accounted for, as well as a block channel for laser safety reasons (S0 - BLOCK, Fig.2). All injection fibers are multimodal graded-index 100/140  $\mu\text{m}$  core/cladding silica fibers (NA = 0.29).

On the infant's brain, the fibers are held together on a neonatal wearable cap, in six probing units (Fig.3b), each incorporating a 100  $\mu\text{m}$  injection fiber in common between TD-NIRS and SCOS and two detection fibers, each exclusive to one technique, as well as a contact sensor to detect possible detachments of the probe and ensure laser safety on the patient. The cap itself is engineered to guarantee comfort in the wearing and minimize the strain

related to the weight of the fibers, while each probing unit is designed to minimize its footprint on the already small newborn's head.

Output TD-NIRS signal backscattered from the brain is coupled to 900  $\mu\text{m}$  core graded-index plastic optical fibers (NA = 0.29) entering a custom, in-house 1x8 fiber switch module (Fig.3a) allowing retrieval of the distributions of time-of-flight using the NIRSBOX single silicon photomultiplier detector and Time Correlated Single-Photon Counting (TCSPC) module.

Conversely, output SCOS signal is retrieved by 800  $\mu\text{m}$  core step-index fibers (NA = 0.39) each coupled to one of the six camera modules of the SCOS device. A master PC is devoted to controlling all the devices, coordinating the measurement, gathering raw TD-NIRS data for extraction of physiological information, e.g. hemoglobin concentrations and  $StO_2$  and communicating with the SCOS MCU for retrieval of the  $CBF$  data. As a result, the device is

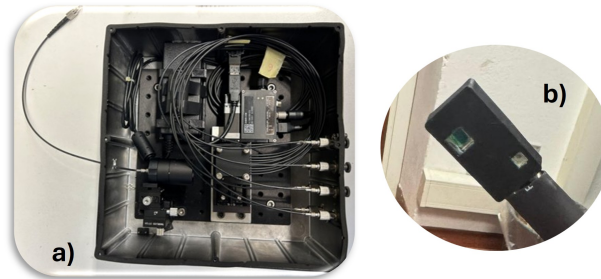

Fig. 3: a) Custom, in-house 1x8 optical fiber switch used for TD-NIRS detection. b) Prototype of a TD-NIRS + SCOS probing unit.

able to acquire and process data in real time to compute instantaneous values of  $CMRO_2 = CBF \cdot (SpO_2 - StO_2)$  in multiple locations on the head, with  $SpO_2$  being systemic saturation measured by a pulse oximeter.

### 3. System characterization

Characterization of the instrument on calibrated tissue phantoms in accordance to standardized, well established protocols for diffuse optics devices were carried out. Specifically, for the TD-NIRS portion of the instrument, responsivity, differential nonlinearity of the TCSPC and features of the instrumental response function were outlined via the BIP protocol [8]; through MEDPHOT [9], we ensured the device is able of correctly and reliably estimating optical parameters of homogeneous diffusive media and nEUROPT [10] checked the capability of retrieving optical information related to deeper tissues, neglecting contribution of upper, extracerebral layers, which are of no interest for the application. As for the SCOS portion of the system, reproducibility and stability were assessed, together with linearity in the ability to follow changes of Brownian diffusion coefficient in liquid phantoms of variable viscosity.

### 4. Conclusion

We will present Prometheus project's technological and clinical goals as well as the current development of the hybrid diffuse optics instrument.

### 5. Acknowledgments and Disclosures

This project was funded by the European Union's research and innovation program "Horizon Europe" under Grant Agreement No. 101099093. AT and DC are co-founders of PIONIRS S.r.l.

### References

1. I. M. Morella et al. *Neuroscience Biobehavioral Reviews*, 142:104892, 2022.
2. A. Torricelli et al. *NeuroImage*, 85:28–50, 2014.
3. C. P. Valdes et al. *Biomed. Opt. Express*, (8):2769–2784.
4. F. Lange and I. Tachtsidis. *Applied Sciences*, 9(8), 2019.
5. A. Quiroga et al. In *Optica Biophotonics Congress: Biomedical Optics 2024*, page JM4A.50. Optica Publishing Group.
6. S. Takahashi. In A. Takada and H. Himmerich, editors, *Psychology and Pathophysiological Outcomes of Eating*, chapter 2. IntechOpen, Rijeka, 2021.
7. M. Lacerenza et al. *Biomed. Opt. Express*, (10):5934–5949.
8. Heidrun Wabnitz et al. *Journal of Biomedical Optics*, 19(8):086010, 2014.
9. Antonio Pifferi et al. *Appl. Opt.*, 44(11):2104–2114, Apr 2005.
10. Heidrun Wabnitz et al. *Journal of Biomedical Optics*, 19(8):086012, 2014.