

PAPER • OPEN ACCESS

Infrared Thermography Measurements over a Tail-Plane Model of a Large Passenger Aircraft

To cite this article: A. Zanotti *et al* 2022 *J. Phys.: Conf. Ser.* **2293** 012014

View the [article online](#) for updates and enhancements.

You may also like

- [FPA-based infrared thermography as applied to the study of cutaneous perspiration and stimulated vascular response in humans](#)
Boris G Vainer

- [Focal plane array based infrared thermography in fine physical experiment](#)
Boris G Vainer

- [Association between physiological stress and skin temperature response after a half marathon](#)
Alejandro Pérez-Guarner, Jose Ignacio Priego-Quesada, Fran Oficial-Casado et al.



ECS Membership = Connection

ECS membership connects you to the electrochemical community:

- Facilitate your research and discovery through ECS meetings which convene scientists from around the world;
- Access professional support through your lifetime career;
- Open up mentorship opportunities across the stages of your career;
- Build relationships that nurture partnership, teamwork—and success!

Join ECS!

Visit electrochem.org/join



Infrared Thermography Measurements over a Tail-Plane Model of a Large Passenger Aircraft

A. Zanotti, A. Rausa, D. Grassi, L. Riccobene, G. Gibertini, A. Guardone, and F. Auteri

Politecnico di Milano, Dipartimento di Scienze e Tecnologie Aerospaziali, via La Masa 34, 20156, Milano, Italy

E-mail: alex.zanotti@polimi.it

Abstract. In the frame of the CleanSky 2 MONNALISA project, a wind-tunnel campaign is planned to test a tail-plane model of a large passenger aircraft by using different measurement techniques. Wind-tunnel test results obtained over a systematic series of model geometries will be used to thoroughly validate a low-order numerical method based on physical modelling that will be developed in the project to evaluate the non-linear aerodynamic characteristics of aircraft lifting surfaces. The present paper describes the main results of the infrared thermography measurements performed in the first wind-tunnel entry to be used to tune RANS solvers and for the fine calibration of the low-order numerical method.

1. Introduction

Sustainable air mobility, to be obtained by developing innovative technologies to cut aircraft emissions of CO₂ and other harmful gases, represents one of the main challenges of aeronautical research in the present years. In particular, this is the mission of Clean Sky 2 Joint Undertaking (CSJU), a public-private partnership between the European Commission and the European aeronautic industry, actively working to achieve environmental performance targets in aeronautics [1]. In this framework, the MONNALISA project is aimed at developing a physics-based, low-order numerical model to allow the fast, accurate prediction of the nonlinear aerodynamic characteristics of lifting surfaces with controls of the type used in the tails of commercial aircraft. Such a low-order model will contribute, as the workhorse, to improve the design and the realisation of new concepts of rear end for advanced and ultra-advanced long range and short/medium range aircraft, improving the aerodynamic efficiency and performance, and reducing the weight of the future aircraft generation. In order to achieve this final goal, MONNALISA project plans the following functional intermediate objectives:

- (i) To develop a systematic series of wind tunnel tests of several models of tails of civil commercial aircraft covering a wide range of planform parameters, with and without simulated ice shapes. The choice of the test parameters will be driven by advanced Uncertainty Quantification techniques [2] coupled to high-fidelity simulations performed through the open-source suite SU2 [3].
- (ii) To integrate the experimental database with a systematic series of numerical simulations of tails of civil commercial aircraft in order to increase the resolution of the database with respect to the control parameters. The proposed approach would permit to detect regions



of the parameter space for which experimental measurements of tails of civil commercial aircraft can be substituted by high-fidelity numerical simulations.

- (iii) To develop bayesian-based calibration methods using the full database of the aerodynamic performance of tails of civil commercial aircraft in order to extend the prediction of the maximum lift coefficient and hinge moment of tail surfaces given by the low-order numerical technique to an arbitrary Reynolds number.
- (iv) To use the developed database to build an error function, which will correct the outcome of the low-order numerical method [4].

The planned wind-tunnel campaign to test the tail-plane model includes different measurement techniques as forces and moments on the whole wing, measurement of the hinge moment acting on the tail-plane control surface, boundary-layer transition line measurement by infrared thermography [5], Particle Image Velocimetry (PIV) surveys, measurement of the displacement of the wing tip and surface flow visualisations. In particular, the present paper is aimed at describing the main results of the infrared thermography measurements that were performed at Politecnico di Milano wind tunnel in the framework of MONNALISA project.

2. Experimental Set-Up

The test activity was performed in the large wind tunnel of Politecnico di Milano (GVPM). The GVPM is a closed-circuit wind tunnel, arranged in a vertical layout with two test sections located on the opposite sides of the loop, as can be observed in Fig.1(a). The present tests were performed in the $4\text{ m} \times 3.84\text{ m}$ Low-Turbulence Test Section [6] (see the particular in Fig. 1(b)), characterised by a maximum wind speed of 55 m/s and a turbulence level less than 0.1%.

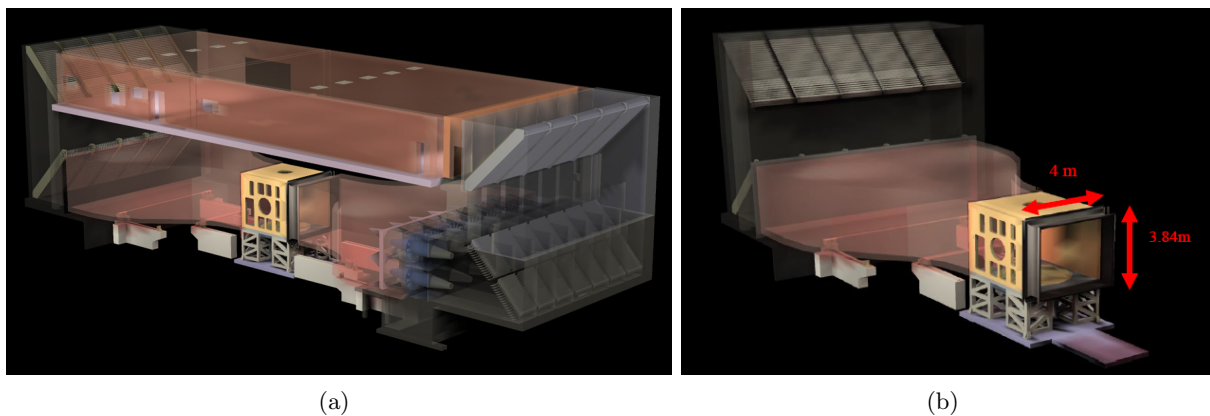

Figure 1. The large wind tunnel of Politecnico di Milano (GVPM): (a) general layout of GVPM; (b) particular of the Low-Turbulence Test Section.

2.1. Tail-Plane Model

A modular wing model with 1.6 m span reproducing the tail-plane of a large passenger aircraft was designed and manufactured for the wind tunnel campaign. The model is divided in three main parts (see the layout shown in Fig. 2):

- leading edge, made by two aluminium machined blocks;
- central part, made by a unique aluminium machined block;
- motorised trailing-edge control surface, made of carbon-fibre composite.

The model allows us to interchange the leading edge and to use removable tips to modify the tail-plane airfoil geometry by design. In order to perform infrared thermography measurements, the aluminium model surfaces were painted with black matt epoxy paint with at least 0.1 mm thickness. The mainframe of the model was attached by a steel flange to a RUAG 767 strain gauge balance that was fixed to the wind tunnel floor.

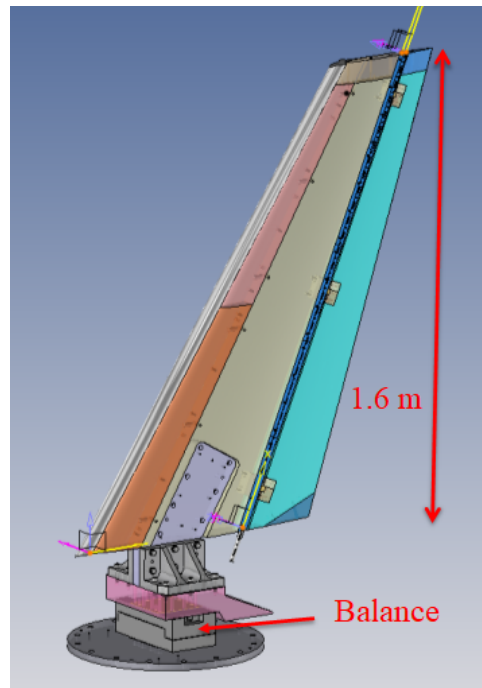

Figure 2. Layout of the tail-plane modular model.

2.2. Wind Tunnel Set-Up and Infrared Thermography Instrumentation

The model set-up in the GVPM test section is shown in Fig. 3. A wooden splitter plate with 2.5 m diameter was used to reduce the boundary layer thickness in front of the wing and to shield the balance and instrumentation cabling. The tail-plane model was attached to an automated turning table embedded in the wind-tunnel floor that enabled us to set the model angle of attack (α). The infrared thermography instrumentation consisted in a FLIR A6751 LWIR Camera equipped with a Strained-Layer Superlattice sensor with 640×512 px resolution (square pixel size of $15 \mu\text{m}$ edge). The thermal sensitivity of the sensor is below 45 mK. The camera was robustly attached to the wind tunnel floor by means of a metallic support structure made of aluminium profiles (see the red box in Fig. 4(a)). A set of markers made of silver conductive paint dots were depicted on the upper and lower surfaces of the wing model to be used for images dewarping and calibration (see the blue box in Fig. 4(a)). The markers were accurately sanded to avoid any jump that could produce or accelerate transition. Three different fields of view (FOV) were considered for the infrared thermography measurements in order to capture with details the root, middle and tip regions of the wing surface (see Fig. 4(b)). The measurements were performed for an angle of attack ranging between $\alpha = -1.1^\circ$ and $\alpha = 2.9^\circ$ at a wind tunnel free-stream velocity (V_∞) equal to 50 m/s. During the tests the model was colder than the air, thus the model was heated by free-stream and the regions with a turbulent boundary layer were detected as warmer than those with a laminar boundary layer. For each model angle of attack

and field of view a series of 500 individual images were acquired with an acquisition frequency of 100 Hz. For each measurement point, reference images were also acquired without the wind.



Figure 3. The tail-plane model mounted in the GVPM test section.

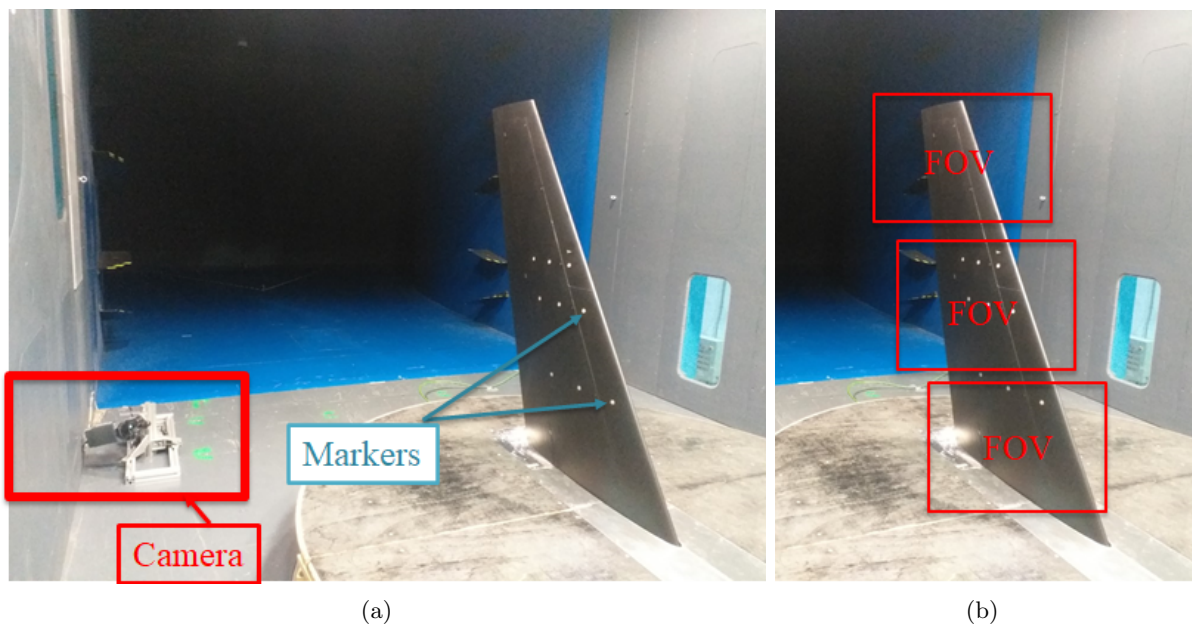

Figure 4. (a) Set-up of the infrared thermography instrumentation; (b) field of views (FOV) of the infrared thermography measurements.

3. Results and Discussion

This section presents the main results of the infrared thermography measurements over the tail-plane model upper surface. In particular, the acquired images for each field of view were

averaged and the difference between the average measurement images with wind on and reference averaged images without wind are presented for each angle of attack tested. Figures 5 and 6 show the infrared measurements results for the middle and root fields of view, respectively.

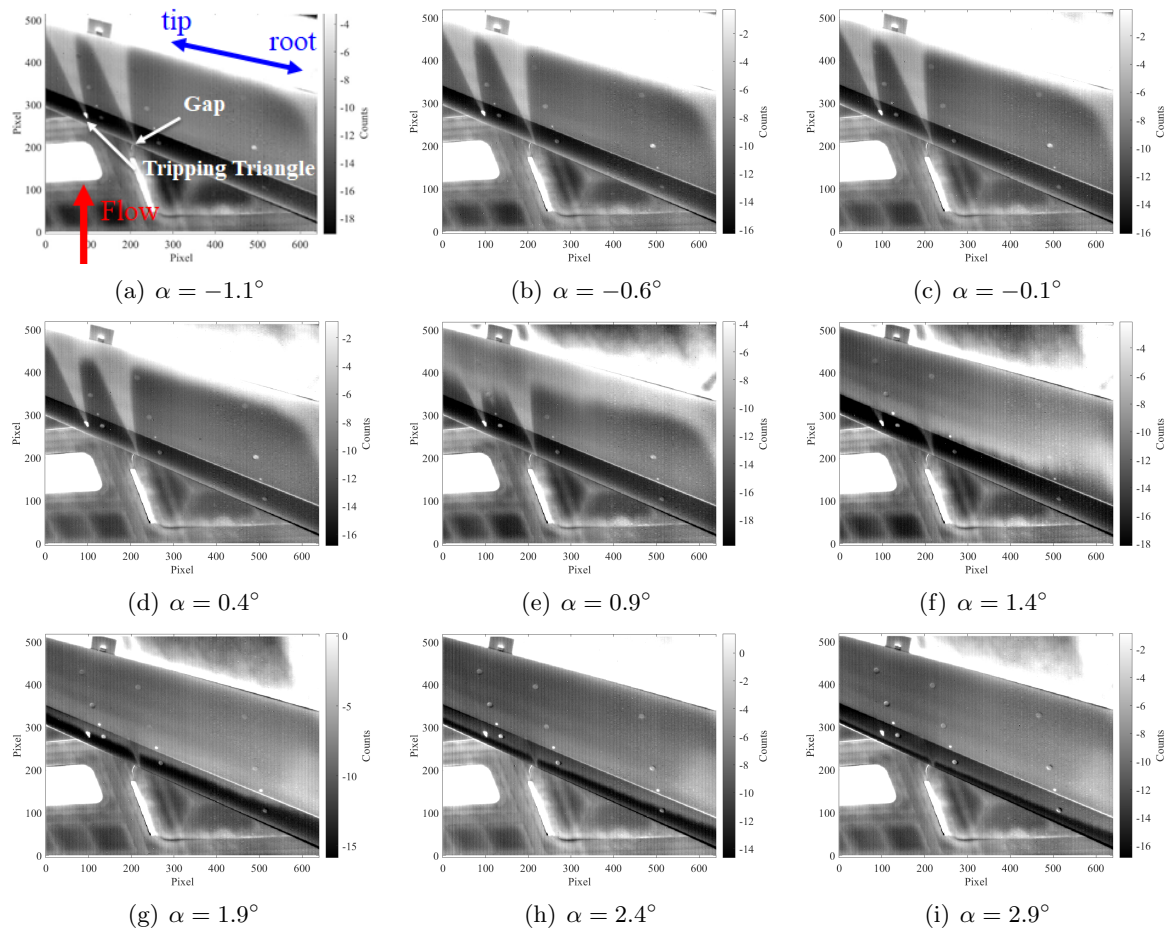

Figure 5. Infrared thermography results for the middle field of view, $V_\infty = 50$ m/s.

In order to test the capabilities of the instrumentation and of the image post-processing to easily detect the boundary layer transition, a tripping triangle was positioned at the model leading edge to be investigated in the middle field of view. The forced laminar to turbulent transition is well detected by the infrared measurements, as can be observed from the clearer triangular region past the tripping triangle indicated by the arrow in Fig. 5(a) showing measurement results at $\alpha = 0^\circ$. A secondary clearer triangular region indicating a forced boundary layer transition can be observed in the middle field of view due to a small gap between the two blocks constituting the leading edge of the tail-plane model (see Fig. 5(a)). Infrared thermography measurements, performed in the range of angle of attack $-1.1^\circ < \alpha < -0.1^\circ$, show that the flow field is apparently laminar over the upper surface of the tail-plane (see Figs. 5(a) - 5(d)). For $\alpha = 0.9^\circ$ (see 5(e)), the transition line can be detected near the airfoil trailing edge control surface and shows that the flow field is quite two-dimensional in this model region. The transition line moves upstream at $\alpha = 1.4^\circ$ (see 5(f)) and reaches the airfoil leading edge at $\alpha = 2.4^\circ$ (see 5(h)) while, at $\alpha = 2.9^\circ$, the flow field appears to be completely turbulent in this area of investigation (see 5(i)).

The infrared thermography measurement performed in the root field of view reflect the

transition line behaviour for the same angle of attack observed in the middle region of the tail-plane model. In this case, though, measurements clearly indicate a strong three-dimensional effect of the flow in the region near the model root. This flow behaviour is related to the junction between the wing root and the splitter plate and suggest a more accurate design of the splitter plate possibly including boundary-layer suction.

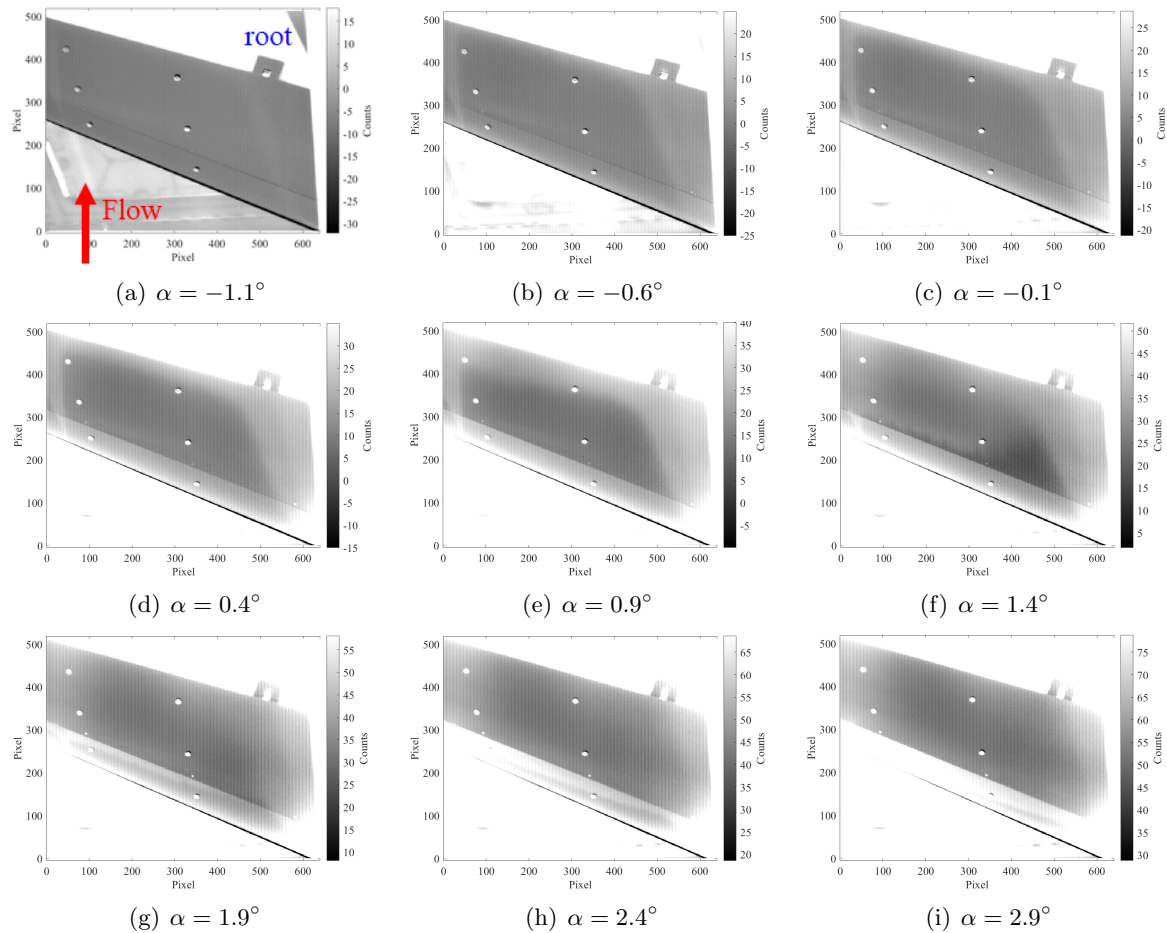

Figure 6. Infrared thermography results for the root field of view, $V_\infty = 50$ m/s.

4. Conclusions

A preliminary wind-tunnel campaign was performed to generate a database of aerodynamic characteristics of swept wings to be used for the development, calibration and validation of numerical methods. In particular, infrared thermography was successfully used to detect the laminar to turbulent transition line over the upper surface of a tailplane model. The obtained experimental database can be considered a benchmark for validating numerical tools with increasing level of fidelity. In order to enhance the aerodynamic database, a further wind-tunnel test entry is planned where infrared thermography will be used to perform measurements also on the tail-plane model with 45° dihedral angle and with different deflections of the trailing edge control surface. The aerodynamic database will be also completed in the future wind tunnel entry with PIV surveys (also with oscillating control surface), load measurements and surface-flow visualizations.

Acknowledgments

This work is part of the MONNALISA project (<https://www.monnalisa-project.eu>) which has received funding from the Clean Sky 2 Joint Undertaking (JU) under grant agreement No 101008257. The JU receives support from the European Union's Horizon 2020 research and innovation programme and the Clean Sky 2 JU members other than the Union. All the material reported in the present paper reflects the view of the authors only. The JU is not responsible for any use that may be made of the information it contains.

References

- [1] Brouckaert J F, Mirville F, Phuah K and Taferner P 2018 Clean Sky research and demonstration programmes for next-generation aircraft engines *The Aeronautical Journal* **122** 1163–1175
- [2] Jofre L, Domino S P and Iaccarino G 2018 A Framework for Characterizing Structural Uncertainty in Large-Eddy Simulation Closures *Flow, Turbulence and Combustion* **100** 341–363
- [3] Palacios F, Alonso J, Duraisamy K, Colonno M, Hicken J, Aranake A, Campos A, Copeland S, Economon T, Lonkar A *et al.* 2013 Stanford university unstructured (su2): an open-source integrated computational environment for multi-physics simulation and design *Proceedings of the 51st AIAA Aerospace Sciences Meeting including the New Horizons Forum and Aerospace Exposition* (Grapevine, TX, USA: AIAA)
- [4] Tugnoli M, Montagnani D, Syal M, Droandi G and Zanotti A 2021 Mid-fidelity approach to aerodynamic simulations of unconventional VTOL aircraft configurations *Aerospace Science and Technology* **115** 106804
- [5] Wolf C C, Gardner A D and Raffel M 2020 Infrared thermography for boundary layer transition measurements *Measurement Science and Technology* **31** 11200
- [6] Gibertini G, Gasparini L and Zasso A 1996 Aerodynamic design of a civil-aeronautical low speed large wind tunnel *Proceedings of the AGARD 79th fluid dynamics panel symposium* (Moscow, Russia: AGARD)