

Comparative analysis of fixed and sun tracking low power PV systems considering energy consumption

George Cristian Lazaroiu ^{a,*}, Michela Longo ^b, Mariacristina Roscia ^c, Mario Pagano ^d

^a Department of Power Systems, University POLITEHNICA of Bucharest, Splaiul Independentei 313, 060042 Bucharest, Romania

^b Department of Energy, Politecnico di Milano, Via Lambruschini 4, 20156 Milan, Italy

^c Dipartimento di Progettazione e Tecnologie, Università di Bergamo, Via Marconi 6, 24044 Bergamo, Italy

^d Dipartimento di Ingegneria Elettrica e delle Tecnologie dell'Informazione, Università degli Studi di Napoli "Federico II", Via Claudio 21, 80125 Napoli, Italy

Received 2 August 2014

Accepted 14 December 2014

Available online 3 January 2015

1. Introduction

The growing trend in environment protection has determined the introduction of Distributed Generation (DG) interconnected to the existing power systems. The DGs can be interconnected at the point of consumption or to the distribution grids, creating smart grids and micro-grids with economic and social benefits for utilities and customers. In the field of renewable sources used for DG in smart grids, especially at distribution network level, one of the focuses is on PV systems [1–4]. The PV systems, converting solar radiation into electrical energy, are pollution-free. Even although their actual cost is still high compared to alternative technologies, the advantages related to PV application are promoting them for massive diffusion. During the period 2005–2013, 550,000 new PV plants were installed in Italy. The PV source's efficiency is related to the ratio among the output electric power and the solar radiation incident on panels. The increase of PV efficiencies is carried on worldwide by many researches to better make use of the sun solar radiation, incident on PV panel. To maximize

the PV system output power for any environmental conditions, both PV technology and system's control are studied in detail. The efficiency of the electric generator depends primarily on the PV technology; commercially Si-panels (i.e. monocrystalline- or twin-Si) present the highest values of 17–18%.

In any PV system, the PV source is equipped with a Maximum Power Point Tracker (MPPT) converter. The MPPT makes possible the PV to operate at its instantaneous Maximum Power Point; alternative MPPT strategies are widely applied. Moreover, the overall efficiency of any solar source could be increased by equipping the PV unit with a sun-tracking system. Indeed, the efficiency of any PV electric generator is optimized when the panel surface is aligned with the direction of sunrays (i.e. the amount of "direct" radiation is maximized). Therefore, a solar tracking system can increase the efficiency of the PV panel by adjusting it to be always pointed toward the sun. The appropriate control of the sun tracking system can allow that the system will result in an optimal solar energy collector [5]. Hence, an increased daily and yearly power production will can be achieved even although the use of a sun tracker is expensive and increases the complexity of the overall system, its use can become cost-effective in many cases, as consequence of providing more output energy throughout years [4].

The optimal angle for a solar energy system depends both on site latitude and the final purpose for which the PV it is to be used

* Corresponding author. Tel.: +40 724528546.

E-mail addresses: clazaroiu@yahoo.com (G.C. Lazaroiu), michela.longo@polimi.it (M. Longo), cristina.roschia@unibg.it (M. Roscia), mario.pagano@unina.it (M. Pagano).

Nomenclature

STC	Standard Test Conditions
NOCT	Nominal Operative Cell Temperature
I_{ph}	current generated by the incidence of light (A)
I_0	reverse saturation current (A)
R_{ph}	shunt equivalent resistance (Ω)
R_s	series equivalent resistance (Ω)
A_i	diode ideality constant
V_T	equivalent voltage, which depends on the temperature (V)
I_{SC}	short circuit current (A)
I_{MP}	maximum power current (A)
V_{OC}	open circuit voltage (V)
V_{MP}	maximum power voltage (V)
MPP	Maximum Power Point

P_{out}	module power output (W)
G	global solar irradiation onto the plane of the module (W/m^2)
A	module area (m^2)
m	mass of the rigid body
a, b	sizes of the rectangular rigid body
I_o	moment of inertia with respect to an axis passing through the center of the mass
r	distance between the two parallel axes
E_{rot}	rotational kinetic energy
ω	angular velocity (rad/s)
E_{source}	electrical energy supplied by the external source
$\eta_{motor}, \eta_{gear}$	efficiencies of the electrical machine and of the mechanical system

[6,7]. Commercially tracking systems are available as either a single-axis or a dual-axis design. The single-axis tracker follows the sun apparent east-to-west movement across the sky, while the dual-axis tracker, in addition to the east-west tracking, controls the solar collector to follow the sun changing tilt angle [4].

In the last years, design methods for solar tracking systems have been worldwide proposed [8–14]. From the analysis, sensing of sun light, providing initial position of the solar panel, control unit design, efficiency assessment, motorization of the tracker are the major challenges of solar tracking systems. Previous studies compared the efficiencies of electricity generated by a fixed and a sun-tracking array. The fixed array are tilted by a fixed angle such that the PV array uses as much as possible the sun radiation at the determined geographical location. The array equipped with sun tracking system adjusts the tilt angle such that to point the sun during its daily movement.

This paper investigates a sun tracker system for PV application. The objective of the research is to highlight the improvement in daily output energy by using the sun tracker. Using two prototypes, experimental tests were carried out during several environmental conditions. The conducted analysis investigates the PV power production, as well as the sun tracker energy consumption. Hence, the impact of the auxiliary internal energy consumption on the amount of total produced energy can be assessed.

2. Photovoltaic electric source

Any PV source is an array of cells (connected in series or parallel) converting the incident solar radiation into electrical energy [14]. The PV array characteristic curve represents a non-linear I - V curve depending on operating voltage, temperature and irradiance. Fig. 1 shows a typical solar array curve at Standard Test Conditions (STC) (irradiance of $1000 W/m^2$, cell temperature of $25^\circ C$, air mass of 1.5).

In Fig. 1, the short-circuit current I_{SC} and open-circuit voltage V_{OC} identify the operative limits on the axes. The area of the largest rectangle that can be fitted under the curve represents the maximum power that the electrical source produces.

Several electric circuits and analytical models can represent the PV electrical behavior [5]. In many applications, the equivalent circuit illustrated in Fig. 2 is used. The current-voltage characteristic is given by:

$$I = I_{ph} - \frac{v + R_s \cdot I}{R_{sh}} - I_{D1} \quad (1)$$

$$I_{D1} = I_0 \cdot \left[\exp\left(\frac{v + R_s \cdot I}{A_i \cdot V_T}\right) - 1 \right]$$

where I and v are the PV terminal current and voltage, I_{ph} represents the photo-current (A); I_0 represents the reverse current (A); R_{sh} represents the shunt equivalent resistance (Ω); R_s represents the series equivalent resistance (Ω); A_i is the diode quality factor; V_T represents the equivalent voltage, which depends on the temperature (V).

The PV module efficiency η is the ratio between the power delivered by the module and the irradiation power per area multiplied by the active area of the module [15]:

$$\eta = \frac{P_{out}}{G \cdot A} \quad (2)$$

The efficiency is maximized when the source operates on the instantaneous Maximum Power Point (MPP). By analyzing (2) it can be observed that PV output power can be increased by improving the accuracy of MPPT algorithm, or/and by maximizing the amount of solar irradiance useful for the conversion into electric energy.

3. PV power systems with sun tracking

The PV systems, generating a DC power, are connected to the 50 Hz mains through an electronic power converter. Fig. 3 shows the electrical power system configuration.

The power converter maximizes the energy production in any atmospheric conditions by controlling the PV output power. This

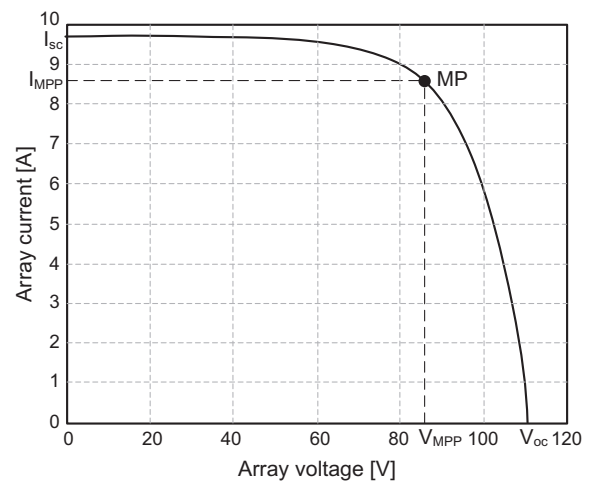

Fig. 1. Photovoltaic (PV) array characteristic curve.

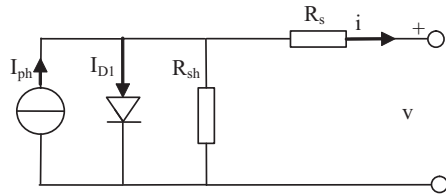

Fig. 2. Photovoltaic (PV) equivalent circuit.

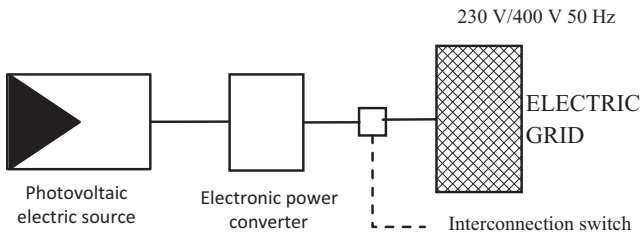

Fig. 3. PV electrical power system configuration.

converter implements the Maximum Power Point Tracker (MPPT), which controls the source efficiency according to the environmental conditions. Therefore, it is usually possible to find applications with one or two stages of power converters. In the first case, the converter is operating to control the MPPT, and balancing source and load/grid requirements. In the second case, the former power electronic stage acts as MPPT, whereas the later follows grid requirements.

As the solar irradiation consists of direct, and indirect or diffuse light (i.e. the light which has been scattered by dust and water particles in the atmosphere), and PV sources primary use the direct irradiation, the behavior of any PV source can be improved by acting on the amount of direct light that falls onto the conversion area. Thus, the PV design practices may also include the use of sun tracking systems.

A sun tracker is an electro-mechanical system used for orienting the PV source in the direction of the sun [9,10]. A sun-tracking mechanism increases the amount of solar energy that can be converted by the source, consequently resulting in a higher annual output power [16].

On the market there are available sun tracking systems, with single-axis or dual-axis design [16–19]. The single-axis tracker follows the east-to-west sun's movement across the sky, while the dual-axis tracker, in addition to east–west tracking, tilts the PV module to follow the sun's changing altitude angle. Sun tracker controllers can be open-loop or closed-loop. Open-loop controllers are algorithm-based and determine the desired position using an imposed algorithm of solar irradiation geometry model, without using feedback. They are simpler and cheaper than the closed-loop ones, but do not control the output of the processes. Consequently, they cannot correct any errors or compensate for disturbances in the system positions [10]. Closed-loop types are sensor-based. The controller receives as input the feedback of measured state variables. Sensors detect relevant parameters induced by the sun and regulate the output yield by the controller. When the weather is suddenly changing, due to permanent position changes, it is worth to verify if the closed-loop sun tracker consumes more energy as gains.

4. Test systems

Two PV electrical power systems of the same peak power are used as test system. Fig. 4 shows the schematic representation of

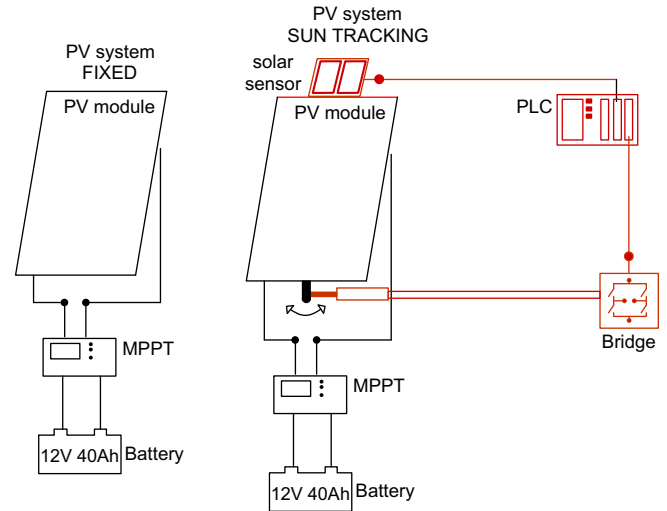

Fig. 4. Fixed and sun-tracking PV power test systems.

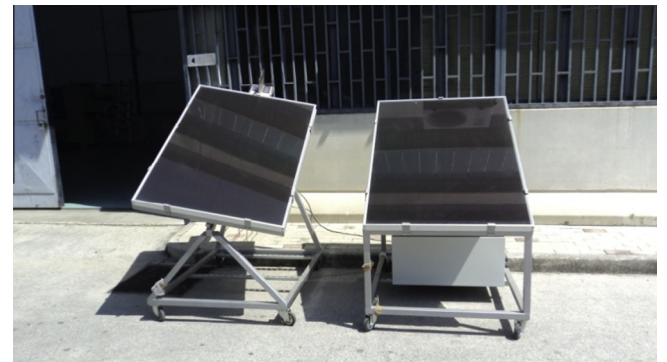

Fig. 5. Sun-tracking and fixed PV test systems.

the test systems, while Fig. 5 illustrates the developed lab prototypes. One system consists of a PV panel fastened to a fixed metallic support, the other consists of a PV panel fastened to a support equipped with a single-axis sun tracker. In this case, the metallic support is made in such a way as to rotate around the axis of the east–west. Both structures are realized by a tilt inclination of 30°. Each system consists of a PV source (with characteristic data reported in Table 1), a MPPT power converter and a 12 V–40 A h electrochemical battery, which is used as electric load (Fig. 4).

The tracker consists of a mechatronic system composed of mechanics, electric drive, and information technology. The PV panel is able to rotate on its axis by an angle of 120°. For realizing a simple and low cost tracking system, the tracker is a closed-loop system using two photo-sensors. The tracker, sensible to the sun position, is using two photo sensors [14], in-built with the PV source. The sensors are able to determine the optimal position of the PV collector, when the illumination of the two photo-sensors becomes equal and balanced. A PLC receives the input control signal and commands a DC electric machine to move the PV module in such direction.

The PV characteristic data at STC (i.e. initial values) and at Nominal Operating Cell Temperature – NOCT (i.e. nominal values) are reported in Table 1. The NOCT is defined as the temperature reached by open circuited cells in a panel under irradiance on cell surface of 800 W/m², air temperature of 20 °C, wind velocity of 1 m/s, and open back side mounting.

The built prototype system is moved by a DC motor powered by a 12 V battery, as shown in Fig. 4. The actuator (i.e. the DC geared

Table 1
PV panel data @ STC and NOCT.

Module	Initial value (STC)	Nominal value (NOCT)
<i>Characteristic data</i>		
Peak power	142.4 Wp	121 Wp
Open-circuit voltage, V_{OC}	60.2 V	59.2 V
Short circuit current, I_{SC}	3.43 A	3.35 A
Maximum power voltage, V_{PM}	48.2 V	45 V
Maximum power current, I_{PM}	2.96 A	2.69 A
Normal Operating Cell Temperature (NOCT)		44 °C
Temperature coefficient, P_{max}	-0.30 mV/°C	-0.30 mV/°C
Temperature coefficient, V_{OC}	+0.07%/°C	+0.07%/°C
Temperature coefficient, I_{SC}	-0.24%/°C	-0.24%/°C

motor) is able to move the installation for a full rotation east-west of 120°. A relay bridge controls the DC motor to rotate clockwise and counter-clockwise. A PLC manages the bridge relay status, based on data from the sensors and according to the two limit switches. These two switches disable the rotation control when the east and west terminal positions are reached.

The energy used by an electrical drive for sun tracking depends on the mass of the PV installation that is moved, as well as on the efficiency of DC motor and gear transmission box (i.e. the actuator). Considering that for this type of application, the angular speed is low, the ideal energy amount to move the PV installation is relatively small (see formulation reported in Appendix A). However, small efficiencies in DC geared-motor and mechanical frictions can strongly influence the real amount of used energy.

For determining the energy consumed by the electrical drive during the tests, a series of experiments imposing the full rotation of the installation were conducted. Fig. 6 shows the block diagram of the circuit and the measuring system. In Fig. 6, A indicates the electrical ammeter, P indicates the panel and the structure that supports the panel, F indicates the “limit” switches for the application, and R indicates the bridge relay controlled by the PLC.

The measurement system is able to record the voltage and the current with a sampling time of 0.5 s. Table 2 reports the results of conducted tests. Fig. 7 illustrates the variation of current function the rotation angle, during two performed experimental tests.

The experimental test results reveal that:

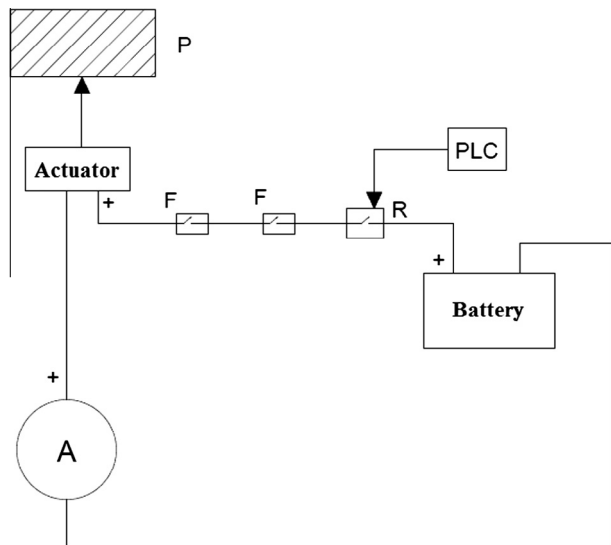

Fig. 6. Measuring circuit of the implemented sun-tracking PV power system.

Table 2
Obtained values of electrical current measured during the experimental tests.

Time (s)	I_1 (A)	I_2 (A)	Rotation angle (°)
0	0	0	0
0.5	1.7	1.64	12
1	1.41	1.37	24
1.5	1.14	1.1	36
2	0.94	0.88	48
2.5	0.71	0.65	60
3	0.5	0.43	72
3.5	0.66	0.64	84
4	0.86	0.82	96
4.5	0.12	0.06	108
5	0	0	120

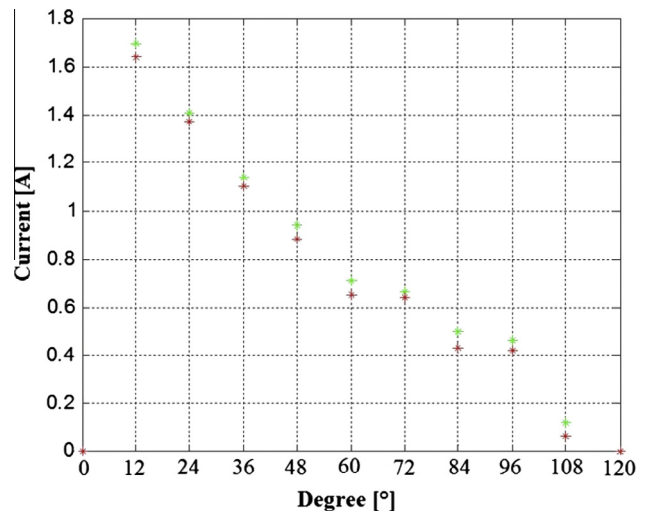

Fig. 7. The typical trend of the currents observed during the experimental campaign.

- (1) the electric drive is able to complete a full rotation east-west in about 5 s;
- (2) the angular speed can be assessed as constant during the rotation, with an average value of 12° every 0.5 s;
- (3) the electric power is maximum at start-up and decreases to minimal values with time.

As the electrical drive is supplied by a 12 V battery source, the average energy consumed by the electrical drive for a full 120° rotation can be estimated as about 50 W s, with a power peak value of about 20 W during the first instants of the rotation. This energy represents the average value that the system must use at sunset to move the installation to the initial east position, in order to be ready for the next day.

5. Experimental results

To evaluate the performances of the two PV systems, these were operated simultaneously. The values of electrical current and voltage were acquired with a 15 min sample rate on an online computer. The systems were exposed to east and the output powers were calculated according to the obtained data.

The investigations were conducted during the months of May and June 2014, for an amount of 30 days. Measurements were performed in the day interval 8.00–19.00. For each system, the instantaneous output power and daily produced energy were recorded.

Based on the results and weather conditions, the monitoring days were classified according to three classes:

- case A: clear sky (15 days);
- case B: partially clear sky (9 days);
- case C: cloudy sky (6 days).

Fig. 8 shows different outputs in specific days of May, in particular May 10, 18 and 25. In this way it is possible to observe the distribution of the output power in different irradiation conditions: "clear sky", "partially clear sky", "cloudy sky". The measured output powers of the PV systems are compared as a function of the time, whereas on the right the amounts of produced energy were compared.

In case A (i.e. "clear sky" conditions), the power varies regularly during the day, reaching its maximum at the middle of the monitoring period, as shown in Fig. 8(a). The first and last hours of the day highlights the effectiveness of the sun tracker. During these hours, the improvement of the output power among the two PV systems is, as expected, extremely relevant. In case B (i.e. "partially clear sky conditions"), the action of the sun tracker is also highlighted at the beginning and ending of the day, as illustrated in Fig. 8(b). Whereas the weather condition makes the action of the sun tracker does not relevant in case C (i.e. cloudy sky conditions),

when the energy spent to move the panel cannot be compensated by the improvement of power, as shown in Fig. 8(c).

In terms of daily average energy, the sun tracker system is able to improve the total produced energy of the PV system. The increase depends on the weather conditions and varies between 12% and 20%. The growth is maximized during "clear sky" days, when the sun tracker's action improves the performance of the PV source especially during the ending hours of the day.

To assess the real gain in the average produced energy with the PV tracking system, the power losses of the auxiliaries used to move the structure must be considered. The useful energy can be defined as the "net" energy, expressed as the difference between the produced energy and the energy consumed by the sun tracker auxiliaries. The minimal energy consumption can be analyzed by adopting a flexible control strategy and an efficient mechanical solution.

As expected, based on the experimental tests reported in Fig. 8, during "clear sky" days the sun tracker produces a discontinuous unidirectional movement of the structure from east-to-west. In case of "partially clear sky" and especially "cloudy sky" days, the movement can result alternative in direction and continuous in time, as consequence of the instantaneous sky varying conditions. In "clear sky" days, it was observed that the solar tracking system is usually active only for few instants, while correcting the position

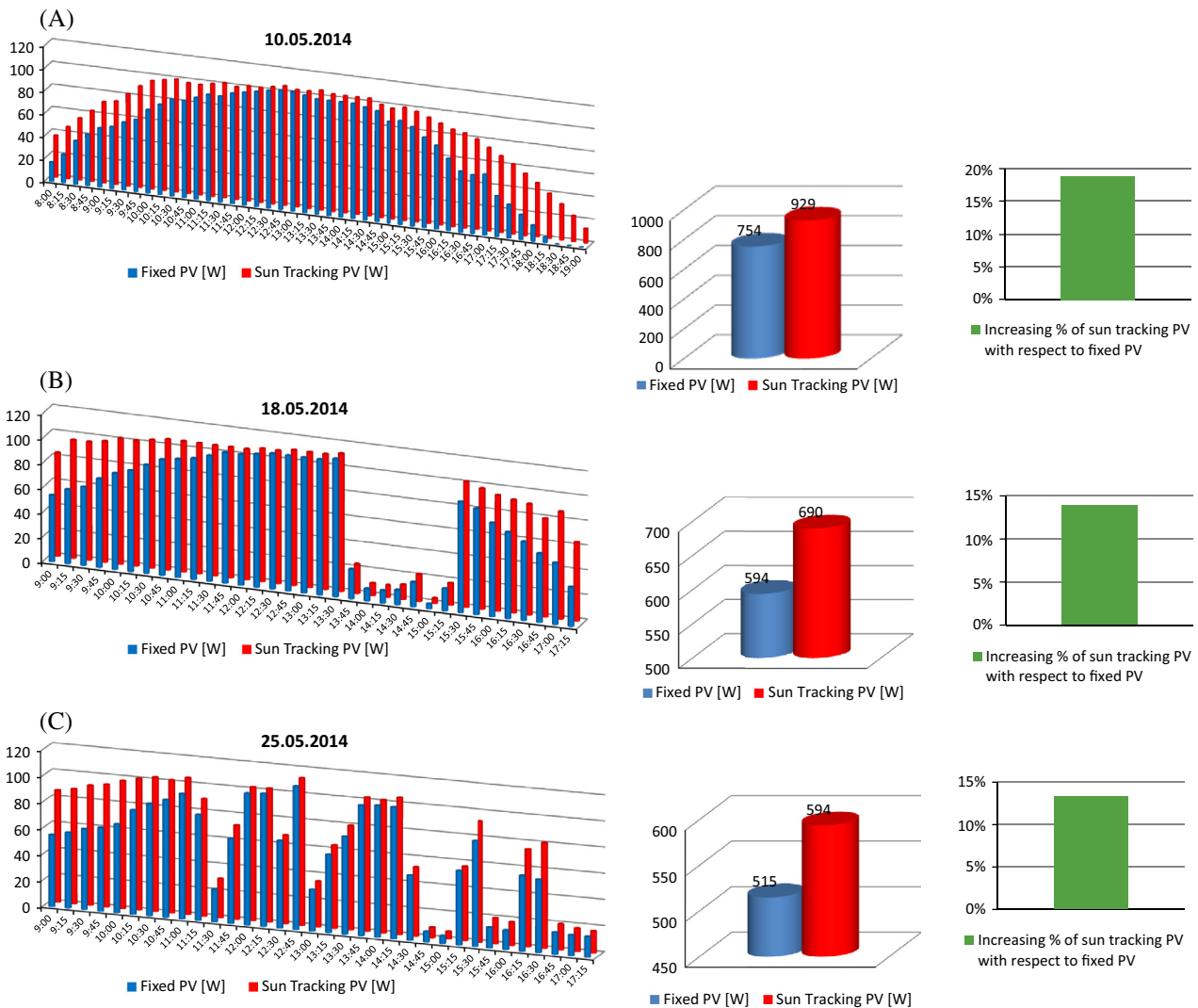

Fig. 8. Output power evaluated in different conditions: (a) clear sky, (b) partially clear sky, and (c) cloudy sky.

of the panel with respect to the sun for every one hour of duty. Thus, the average value of the daily consumed energy by the test system (i.e. actuator losses) was estimated around 100–200 W s. Similar results are obtained for different days and weather conditions (warm and cold conditions). The power losses due to moving the structure are small compared to the gained power [20]. Thus, considering the increase of energy used by the solar tracking system (a few percent of the produced energy), it is possible to summarize that the net energy produced by the solar tracker can be estimated as almost equal to the total energy produced by the system.

6. Conclusions

Maximizing the energy yield of PV systems in order to generate the highest possible return on investment is an ongoing research. The objective of this paper is to compare two alternative photovoltaic systems. One is a fixed, whereas the second one is a PV system equipped with a sun tracker. The sun tracker is able to increase the amount of daily direct radiation incident on the source. The design of the sun tracker was deeply investigated. In particular, indications to estimate the 50 W s energy consumed by the sun tracker were analyzed in detail. For comparing the performances of the two systems, two PV lab prototypes were built and investigated during a 30 days monitoring campaign. The experimental results highlight the significant increase 12–20% of the produced energy by using the sun tracker. In addition, the results obtained during “clear sky” days show that any solar tracker must be designed such that to limit the energy consumption caused by small variations of solar irradiation.

Based on the results obtained during “partially clear sky” and “cloudy sky” days, further research to countermeasure the random irradiation variations must be conducted. In this way, the energy consumption associated with unnecessary rotations of PV source can be limited.

Appendix A

The moment of inertia of any rectangular rigid body respect to an axis passing through the center of the mass, can be expressed as:

$$i_o = m \cdot \left[\frac{(a^2 + b^2)}{12} \right]$$

If the rotation axis does not pass through the center of the mass, the Huygens–Steiner theorem provides a convenient expression to compute the moment of inertia of a rigid body around an axis z , which is parallel to the axis passing through the center of the mass. The moment of inertia i_z with respect to axis z is given by:

$$i_z = i_o + m \cdot r^2$$

where r is the distance between the two parallel axes.

The energy consumed for rotating any rigid body with respect to an axis passing through the center of the mass, E_{rot} , is the

rotational kinetic energy. For any angular velocity ω , E_{rot} depends on the rotational moment of inertia i_o by:

$$E_{rot} = \frac{1}{2} \cdot i_o \cdot \omega^2$$

The energy E_{source} , supplied by the external source to the electrical drive for sun tracking, depends also on the efficiencies of the DC motor and gear transmission box. Therefore, E_{source} can be assessed using:

$$E_{source} = \frac{E_{rot}}{\eta_{motor} \cdot \eta_{gear}}$$

References

- [1] Senpinar A, Cebeci M. Evaluation of power output for fixed and two-axis tracking PV arrays. *Appl Energy* 2012;92:677–85.
- [2] Koussa M, Cheknane A, Hadji S, Haddadi M, Noureddine S. Measured and modelled improvement in solar energy yield from flat plate photovoltaic systems utilizing different tracking systems and under a range of environmental conditions. *Appl Energy* 2011;88:1756–71.
- [3] Cruz-Peragón F, Pedro J, Peláez C, Francisco A, López-García R, Palomar JM. An approach to evaluate the energy advantage of two axes solar tracking systems in Spain. *Appl Energy* 2011;88:5131–42.
- [4] Al-Mohamad A. Efficiency improvements of photo-voltaic panels using a sun tracking system. *Appl Energy* 2004;79:345–54.
- [5] Seme S, Stumberger G, Voric J. Maximum efficiency trajectories of a two axis sun tracking system determined considering system consumption. *IEEE Trans Power Electron* 2011;26:1280–9.
- [6] Kaldellis J, Zafirakis D. Experimental investigation of the optimum photovoltaic panels' tilt angle during the summer period. *Energy* 2012;38: 305–14.
- [7] Ya'Acob ME, Hizam H, Khatib T, Radzi M, Amran M. A comparative study of three types of grid connected photovoltaic system based on actual performance. *Energy Convers Manage* 2014;78:8–13.
- [8] Sefa I, Demirtas M, Çolak I. Application of one-axis sun tracking system. *Energy Convers Manage* 2009;50:2709–18.
- [9] Mousazadeh H, Keyhani A, Javadi A, Mobli H, Abrinia K, Sharifi A. A review of principle and sun-tracking methods for maximizing solar systems output. *Renew Sustain Energy Rev* 2009;13:1800–18.
- [10] Lee CY, Chou PC, Chiang CM, Lin CF. Sun tracking systems: a review. *Sensors* 2009;9:3875–90.
- [11] Kassem A, Hamad M. Microcontroller-based multi-function solar tracking system. In: *Proc IEEE int systems conference (SysCon)*; 2011. p. 13–6.
- [12] Bentaher H, Kaich H, Ayadi N, Hmouda MB, Maalej A, Lemmer U. A simple tracking system to monitor solar PV panels. *Energy Convers Manage* 2014;78:872–5.
- [13] Kelly AN, Gibson TL. Increasing the solar photovoltaic energy capture on sunny and cloudy days. *Sol Energy* 2011;85:111–25.
- [14] Singh GK. Solar power generation by PV (photovoltaic) technology: a review. *Energy* 2013;53:1–13.
- [15] Durisch W, Bitnar B, Mayor JC, Kiess H, Lam KH, Close J. Efficiency model for photovoltaic modules and demonstration of its application to energy yield estimation. *Sol Energy Mater Sol Cells* 2007;91:79–84.
- [16] Huang BJ, Ding WL, Huang YC. Long-term field test of solar PV power generation using one-axis 3-position sun tracker. *Sol Energy* 2011;85: 1935–44.
- [17] Koussa M, Cheknane A, Hadji S, Haddadi M, Noureddine S. Measured and modelled improvement in solar energy yield from flat plate photovoltaic systems utilizing different tracking systems and under a range of environmental conditions. *Appl Energy* 2011;88(5):1756–71.
- [18] Tian-Pau Chang. Output energy of a photovoltaic module mounted on a single axis tracking system. *Appl Energy* 2009;86:2071–8.
- [19] Eke R, Senturk A. Performance comparison of a double-axis sun tracking versus fixed PV system. *Sol Energy* 2012;86:2665–72.
- [20] Serhan M, El-Chaar L. Two axis sun tracking system: comparison with a fixed system. In: *Proceedings of international conference on renewable energy and power quality*, Granada, Spain, 23–25 March 2010. <<http://www.icrepq.com/icrepq%2710/227-Serhan.pdf>>.