

Smart Grid on field application in the Italian framework: the A.S.S.E.M. project

Maurizio Delfanti^{1*}, Davide Falabretti¹, Massimo Fiori², Marco Merlo¹

¹Politecnico di Milano – Department of Energy, Via La Masa 34, 20156, Milano, Italy

²A.S.S.E.M. SpA, Loc. Colotto 11, 62027, San Severino Marche (MC), Italy

Abstract

Today, distribution systems are subject to an increasing penetration of dispersed generation. This is an important step towards a new green, sustainable, paradigm of energy. However, injections from renewables on distribution networks can cause technical issues in power systems, which require to put in operation new monitoring and control procedures and apparatuses. The paper details the Smart Grid experiment developed by A.S.S.E.M. (a DSO of Central Italy) on its distribution grid. The project, incentivized by the Italian Energy Authority in the framework of Resolution ARG/elt 39/10, involves the installation of protection and automation devices in the HV/MV substation and over the distribution grid, ten MV users and one LV user. The following innovative features are provided: increase in the reliability of Loss of Mains protections by transfer trip messages; logic selectivity between protections; centralized voltage control; real-time monitoring and control of generation. This project, together with the other pilot applications supported by Res. ARG/elt 39/10, will provide important information to the Italian Energy Authority, useful to define an output-based regulation for Smart Grids.

Keywords: Smart grid, dispersed generation, distribution network, IEC 61850, transfer trip

Nomenclature

AEEG	Italian Energy Authority (Autorità per l'Energia Elettrica il Gas ed il Sistema Idrico)
AVR	Automatic Voltage Regulator
BCU	Bay Control Unit
CT	Current Transformer
DG	Dispersed Generation
DGC	DG Controller
DGPM	DG Production Meter
DSO	Distribution System Operator
FO	Fiber Optic
FPR	Feeder Protection Relay

* Corresponding author.

E-mail: maurizio.delfanti@polimi.it.

Tel. +39 02 2399 3719.

Fax +39 02 2399 8566.

FPI	Fault Passage Indicator
HV	High Voltage
IPR	Interface Protection Relay
LoM	Loss of Mains
LV	Low Voltage
MV	Medium Voltage
OLTC	On-Load Tap Changer
ORPF	Optimal Reactive Power Flow
PQM	Power Quality Meter
PV	Photovoltaic
RES	Renewable Energy Source
RPF	Reverse Power Flow
SaS	Satellite Substation
SG	Smart Grid
TSO	Transmission System Operator
UEM	User Exchange Meter
VT	Voltage Transformer

1. Introduction

Renewable Energy Sources (RESs) are a key point for a new, sustainable, energy ecosystem. Nevertheless, RESs introduce some drawbacks in the operation of electric networks, which must be properly addressed in order to avoid deteriorating power quality, reliability and supply efficiency [1][2]. The increasing penetration of Dispersed Generation (DG) currently affecting power systems requires a conceptual revolution of distribution networks: these grids have been designed as passive systems, with unidirectional electricity flows from the HV network to MV/LV grids; however, DG injections can cause power flows to reverse (Reverse Power Flow: RPF). In this situation, the distribution grid is an active system and its operation is no longer consistent with its original design criteria. A main problem concerns the Loss of Mains (LoM) protections equipping DG power plants, which are less reliable than in the passive scenario [3]; they can be the cause of extended outages on the transmission level [4]. Further issues regard the effective management, monitoring and forecasting of DG injections, with important consequences on both the HV level (e.g., to collect the needed dispatching resources on the transmission system) and the MV/LV system (e.g., voltage control) [5].

The term “Smart Grid” (SG) identifies the solutions to overcome these problems [6]: they make extensive use of innovative products and services, combined with intelligent monitoring, control, communication and self-healing technologies. The development and experimentation of SG solutions covers a pivotal role in all the strategies recently proposed at EU level to promote the evolution towards a new, efficient and sustainable, energy paradigm [7].

In particular, in EU a great effort in this direction has been made by the UK energy regulator Ofgem, which in 2010 established the Low Carbon Networks Fund (LCNF): the fund aims at encouraging DSOs to develop Smart Grid projects towards a low carbon economy. In 2011, this programme funded six network projects [8], which, according to the Ofgem minimum requirements, provide advances in the operation of distribution systems:

novel equipment (including control and communications systems, and the relevant software), novel operational practices, along with novel commercial arrangements.

With a similar approach, in Italy, the Energy Authority (Autorità per l'Energia Elettrica il Gas ed il Sistema Idrico, AEEG) recognized a central role to the DSO in the evolution of electrical networks towards the SG concept. In 2010, AEEG launched a selection process for SG demonstration projects, providing an innovative incentive scheme for SG experiments implemented on active MV networks (Resolution ARG/elt 39/10 [9]). The projects worthy for incentive are granted an extra-WACC (Weighted Average Cost of Capital) of +2% (on top of the "ordinary" WACC, equal to 7%, for distribution network investments) for a period of twelve years. To gain access to the selection procedure, the project proposals must satisfy a set of minimum requirements:

- the project has to involve a real MV network with Passive and Active Users;
- the MV network must be an active network, i.e. it has to show, in the current condition, RPF at the HV/MV interface for at least 1% of the year;
- the MV network has to be equipped with real-time monitoring systems able to collect all the data needed for the project evaluation;
- non-proprietary communication protocols must be used by DSO to communicate with Active Users (AUs).

In addition to these minimum requirements, the demonstration projects can implement further "smart" functionalities: providing bidirectional communication with final customers to develop demand response strategies (including recharging infrastructures for electric vehicles), or storage solutions, to guarantee active power modulation at the TSO/DSO interface. The worth of the project is evaluated in three complementary areas: grid technology innovation, new grid services and User participation.

By this initiative, AEEG aims to collect detailed data from the experimental projects, useful to define a novel regulation for SG investments, based on the actual effects of interventions on the operational performance of the grid (output-based regulation through Key Performance Indexes) [10].

In the framework of this procedure, A.S.S.E.M. SpA (Azienda San SEverino Marche SpA; a small DSO located in Central Italy) submitted an experiment proposal aimed at introducing a set of innovative automation and control features within its distribution network. The proposal has been approved by AEEG, together with other seven projects [11], through Res. ARG/elt 12/11 [12].

In the following, the paper will focus on the main features, architectural characteristics and beneficial effects of the A.S.S.E.M. SG experiment. In particular, in Section 2 the architecture of the Project is explained, illustrating the communication system and the apparatuses installed on the MV grid and on DG power plants. Then, the main functions of the Project are detailed: a novel technique for the effective management of faults and Interface Protection Relays of AUs (Section 3), and a centralized voltage regulation based on the power injections of DG units (Section 4). Finally, conclusions are provided in Section 5.

2. The Project architecture

The SG pilot project is implemented on the 20 kV electricity distribution network (Figure

1) of San Severino Marche (a town of about 13,000 inhabitants in the Macerata province). The experiment involves the A.S.S.E.M. control center, a HV/MV substation and a MV/MV Satellite Substation (SaS), ten MV Active Users and one LV Active User (Table 1). The devices widespread over the distribution network are connected with a suitable communication system, realized by mobile network (GSM/3G), Wi-Fi and Fiber Optic (FO) technologies (Figure 2).

According to the requirements stated by Res. ARG/elt 39/10, the Project is implemented on an active MV network (i.e., with RPF at the HV/MV interface for at least 1% of the year). The active behavior of the distribution system involved in the Project is highlighted by Figure 3, which shows the active and reactive power flows measured at the interface with the HV grid in the interval 6 - 19 January 2014: during a significant number of hours the MV grid injects active power in the transmission system (this fact is even more evident in summertime, when the PV production is greater).

Non-proprietary communication protocols are used to communicate with Users and devices over the network (IEC 61850 [13]). The MV network is equipped with real-time monitoring systems able to collect all data needed for the Project evaluation.

The Project provides the following main features:

1. increase in the reliability of LoM protection of AUs by transfer trip messages with “fail-safe” logic, in order to prevent the unintentional island operation of DG power plants or their unwanted disconnection with possible domino effects on DG units;
2. novel fault management based on the selective interlocking between the protection relays in the HV/MV substation and SaS, and on the remote control of switches along lines, with the purpose to improve Users’ continuity of service;
3. centralized voltage regulation performed by modulating reactive power injections of each DG unit, aimed at increasing the network Hosting Capacity for RESs, improving the voltage quality and the distribution service efficiency;
4. limitation/modulation in emergency of the active power injected by each DG unit;
5. monitoring and control of DG injections, to provide data suitably categorized (DG; load) to the TSO and to allow the management of DG power injections according to the needs of both the transmission and the distribution network.

The heart of the SG architecture is the core processing unit sited in the distribution grid’s control center (A.S.S.E.M. control center is located close to the HV/MV substation). It provides the usual capabilities of conventional SCADA (Supervisory Control And Data Acquisition) and DMS (Distribution Management System) units, plus the novel SG features conceived in the Project. In order to ensure a proper reliability, the core unit is set up on two redounded servers.

In detail, the SCADA/DMS system allows the DSO to have a real-time overview of the MV network (grid topology, sectionalizing and tie-switches condition, voltage values, AUs power injections, feeder power flows, etc.) and to control the peripheral units and generators on the grid (e.g., for maintenance disconnections, active power modulation, etc.). In addition, it performs fault selection and isolation procedures by coordinating the maneuvers of the switch disconnectors in the MV/LV substations and the reclosing procedures of the circuit breakers in HV/MV substation and SaS. The core unit also supervises the exchange of transfer trip and keep-alive messages with the Interface Protection Relay (IPR) of DG power plants (see Section 3) and manages the communication with the TSO, to provide data about the DG/load subtended to the

distribution grid and to enable the reception of limitation commands for DG power injections.

The SCADA/DMS system is equipped with suitable computational and data management software. The voltage regulation algorithm, which optimizes the voltage profiles on the MV network through the control of DG reactive power injections and supervises the Automatic Voltage Regulator (AVR) of HV/MV transformers (see Section 4), is computed by DiGSILENT PowerFactory [14]. All the operational data acquired on the network (e.g., measurements, events, etc.) and the logs of all the commands assigned to the apparatuses on field are stored in an Oracle Server database [15] installed on the core unit.

In addition to the SCADA/DMS system, to acquire all the data needed for the system operation and to carry out the consequent control actions, the PS is equipped with novel protection and automation devices, which replace the conventional devices usually installed in HV/MV substations. A brief description of these apparatuses is reported in Table 2, while Figure 4 provides an outlook of the overall functional SG architecture in the HV/MV substation.

The core unit is interfaced with the devices over the distribution grid by means of the IEC 61850 communication system. Operators can access the system both locally and remotely from the Web (through a Web Human Machine Interface).

The Satellite Substation (SaS) is a MV substation with 5 outgoing MV feeders (see Figure 1). Each feeder is equipped with a circuit breaker piloted by a FPR equivalent to the relays installed in HV/MV substation atop of each MV feeder.

The SaS is equipped with a subset of the equipment of the HV/MV substation: atop of each outgoing MV feeder, a circuit breaker piloted by a FPR able to send transfer trip messages to the downstream DG units and to the upstream FPRs is installed; in addition, in the SaS there is an acquisition system for the voltage/current measurements and a communication interface with the HV/MV substation (Fiber Optic). Within the SG infrastructure, the SaS is seen as an extension of the HV/MV substation (same level in the IEC 61850 protocol architecture).

Each MV AU involved in the Project is equipped with the devices shown in Figure 5 and described in Table 2. The automation systems provided for MV AUs can also be applied to MV/LV substations, e.g., for the monitoring and control of switch disconnectors along lines.

2.1. The communication system

The communication system provided in the Project is a combination of three different transmission vectors: FO, Wi-Fi and mobile network (Figure 2).

Two communication channels in FO depart from the HV/MV substation: a FO line links the SaS to the central system, while the second one reaches the industrial area of San Severino Marche, where most of AUs are located. The FO link between the HV/MV substation and the SaS is installed partially on overhead lines and partially on underground lines, while the link towards the eastern area of the city is created with underground FO.

Despite FO being a very effective data transmission technology, especially when high data rates are needed, sometimes its installation can be difficult, e.g. when the laying is carried out on existing electrical lines, as in the case of this experiment. In the Project, in order to

connect AUs in sites difficult to reach by FO, Wi-Fi links have been used. The experimental configuration includes three Wi-Fi links towards four different AUs.

Communication with the UAs connected by the Wi-Fi communication system is backed-up by the mobile network (AUs 2, 3, 9 and 10). This redundancy is adopted to increase the reliability of the system and to allow a comparative performance assessment of the two carriers. The LV User (AU 11) has only access to the mobile network, to provide a cheaper solution (easily deployable in the future). The mobile network is based on a Layer 3 MPLS network connecting the HV/MV substation and AUs. Network access is attained by Users through HSDPA (High-Speed Downlink Packet Access) technology (each AU is equipped with a high-gain directional antenna to improve the communication quality), while the HV/MV substation is wired-connected to the main communication network with a 2 Mbps access point.

All the devices of the Project are assigned a static IP address within the Virtual Private Network: they are univocally defined within the IEC 61850 protocol architecture and synchronized with a SNTP server through a GPS antenna.

The choice of adopting the IEC 61850 protocol instead of the conventional protocols for network automation (e.g., IEC 60870-5 protocols class), used also in recent SG experiments [16], is motivated by its great interoperability, its support to GOOSE messages, allowing for a fast communication (e.g., to meet the time requirements of protections coordination), and the positive feedback obtained by the international scientific community [17]. These factors will contribute to the future deployment of the SG solution proposed, i.e. to the adoption of this experimental prototype as reference standard for the future SGs. The future protocol interoperability of the SG architecture is confirmed also by the fact that IEC 61850 has been assumed as reference protocol in most of projects in the framework of the Italian Res. ARG/elt 39/10 [11].

Table 3 shows a rough estimation of the investment costs for the connection of HV/MV substation, SaS and AUs to the communication system, and the yearly charge required for the service. One can observe that the economic figures are significantly higher than those commonly applied in small industry/domestic applications. This fact is attributable, on the one hand, to the technical requirements needed in the experiment (e.g., maximum Round Trip Time close to 100 ms, VPN with Level 2 tunneling, etc.) and, on the other hand, to the small number of sites involved: in a scenario of full deployment of the experimental solution, the costs incurred for the communication system could be shared among a greater number of AUs, without significant reductions in the performance.

Table 4 reports further details on the characteristics of the communication system.

3. The novel IPR and fault management proposed in the Project

In recent years, the efforts of TSOs/DSOs in identifying an effective automation and protection architecture able to ensure adequate standards of reliability and quality of the network operation, also in the presence of great amounts of DG, increased considerably. However, although many projects started recently, few details are present in the literature on how the experimental architecture performs during the real-life operation.

In the Schema project [18], the Italian DSO Enel evaluated the operational efficiency of a closed ring network configuration to provide a suitable redundancy against faults. In such a project, and in the Enel project funded by Res. ARG/elt 39/10 [11], advanced control and

protection systems are adopted, based on IEC 61850 sensors and fault detectors over the MV network; in addition, circuit breakers are used along feeders instead of disconnectors. Another interesting experiment in this field is named IDE4L [19]. It envisages an advanced protection system based on the IEC 61850 protocol (e.g., protection coordination for ring operated feeders) and the exchange of GOOSE messages.

In the context of the novel techniques of automation and grid protection, the main purpose of the A.S.SE.M. project is to overcome the poor performance of the passive IPRs and to deploy effective protection configurations based on the remote relays coordination.

To improve the operational performance of the power system with respect to the current scenario, the Project provides an evolution in the management of IPR of AUs. Moreover, the communication system is used to perform logic selectivity among MV protections, increasing the Quality of Service of Users. Today, in fact, the method usually adopted for the protection of MV distribution networks is based on the presence, atop of each MV feeder, of a circuit breaker piloted by a protection relay (50, 51, 67N: that is, respectively, instantaneous overcurrent, inverse time overcurrent and directional earth-fault protections). As result of the tripping of a FPR detecting a fault, the entire line is disconnected. First, an automatic reclosing procedure is carried out to try to restore the service (temporary faults). At a second stage, if the fault is permanent, the feeder is put out of service, and the supply restoration is accomplished through the remote control of switch disconnectors (usually by manual orders, based on subsequent maneuvers). To accomplish the fault current extinction, it is essential that, when the circuit breaker atop of the line opens, the IPR of the subtended DG detects the loss of mains and disconnects the relevant power plant (within the first reclosing maneuver: 400/600 ms on Italian MV distribution networks). This action is performed according to network voltage and frequency (passive islanding detection methods): if deviations beyond the given thresholds are detected, the IPR trips.

Problems could occur according to load and generation conditions: if the generation equals the load, some DG power plants downstream the MV feeder could remain in operation after the FPR tripping (LoM protections do not detect significant deviations on network voltage/frequency).

A similar issue can happen as a result of the tripping of the protections on the HV section of HV/MV substation or of the MV protections of HV/MV transformer: if the generation and load on the whole MV grid are balanced, the islanded operation of the entire MV network could occur. To avoid these phenomena, very narrow frequency/voltage thresholds have to be adopted on the IPR. However, with narrow thresholds, there is greater possibility of nuisance tripping of the IPRs for faults on adjacent MV feeders. Furthermore, a massive DG disconnection could take place in case of severe frequency transients on the interconnected European system [4].

3.1. Novel management of Interface Protection Relays of Active Users

The approach proposed for the management of the IPR of AUs provides as main feature the exchange of information between the Feeder Protection Relay (FPR) in HV/MV substation/SaS and the IPR located at the DG premises, in order to increase LoM protections reliability. This feature has been coordinated with the technical requirements stated by Standards CEI 0-16 [21] and CEI 0-21[22], and by Annex A.70 [23] of the Italian Grid Code, setting up new prescriptions for the operation of IPRs.

In addition, the IPR has been equipped with a suitable logic enabling the DSO/TSO, during

emergency conditions, to control the disconnection of DG power plants underlying the distribution network (scheduled DG shedding), according to the recent requirements of the Terna's Annex A.72 [24].

In the following, we focus on the theoretical and experimental analysis of the first feature, aiming to overcome the poor performance of actual IPRs, which operate only with local information (voltage magnitude and frequency). This is carried out by exchanging two types of messages with the IPRs: "keep-alive" and "transfer trip" messages.

As clarified in [25], the remote control of AUs' IPRs is the most reliable method to avoid the islanding of DG units. In fact, local passive methods generally have a large Non-Detection Zone (NDZ) [26], i.e. large bands in frequency and voltage, centered on the nominal values, within which the islanded operation of generators is not detected. This is necessary in order to avoid the IPS's nuisance tripping, e.g. in the case of perturbances on the HV system. On the other hand, although the active methods are more reliable, they can have detrimental effects on voltage quality, due to the injection of active signals, for example, in the inverter output current. Some experiments, such as the Smart Grid project of Hydro-Québec [27], proposed as approach for the anti-islanding the short-circuiting of MV feeder: i.e. just prior to reclosing of the substation breaker, the feeder is momentarily short-circuited, forcing any remaining DG to disconnect based on line protection. In Italy, this approach is considered not admissible, because of the stringent requirements on power quality stated by national regulations.

In the envisaged architecture, keep-alive messages monitor cyclically (e.g., every second) the proper operation of the communication channel between the central system and the AU. If the communication system works properly, the LoM protection relay keeps wider settings (wide frequency thresholds: 47.5-51.5 Hz); on the other hand, if the communication fails (a keep-alive message is not received), the IPR comes back to operate based on local information (narrow frequency thresholds, 49.8-50.2 Hz, or activation of the voltage unlock logic in Figure 8). By adopting this protective strategy, nuisance tripping for faults on MV adjacent feeders is avoided. Moreover, the risk for the transmission system related to the massive disconnection of DG is greatly reduced (during normal operation the wider, less sensitive, frequency thresholds are adopted) [4].

The transfer trip message is sent by the FPR to the subtended IPRs in order to ensure the DG disconnection when the feeder protection trips (Figure 6). Moreover, the transfer trip avoids the island operation of the whole distribution grid that could occur after the separation from the HV network. Also in this case, the transfer trip message is sent to the IPRs by the FPRs (Figure 7): the tripping of the protections on the HV side of the substation is detected by the exchange of data through the FO LAN. The condition of the circuit breakers atop of feeders is not altered. A time limit of 200 ms is admitted between the transmission and reception of the transfer trip message: this allows DG to be surely disconnected before the first cycle of automatic reclosing.

The transfer trip message (based on a GOOSE message defined by protocol IEC 61850) is sent directly by FPRs to IPRs to minimize the time required for the data processing and transmission. However, the process requires the supervision of the core system: the correspondence FPR-IPRs must be kept properly up to date to allow the FPR upstream of the faulted line to disconnect all (and only) the underlying DG units. Changes in the network configuration can entail the transfer of some AUs from a feeder to another one. To this purpose, the core unit configures the communication interface of AUs (routers) in real-

time, to associate the FPR with the underlying IPRs. This way a selectivity of MAC addresses is obtained: each router properly filters the GOOSE messages sent on the Wide Area Network in order to receive only the information addressed to the relevant IPR.

The logic implemented on the IPR of the AUs involved in the Project is shown in Figure 8. As already mentioned, in the presence of the always-on communication with the HV/MV substation (the keep-alive messages are received with the expected timings), the wider frequency thresholds are adopted and the DG disconnection is ensured by the transfer trip message. When the communication system is unavailable, according to the Standard CEI 0-16, frequency thresholds are managed by means of a voltage unlock logic: if the direct, inverse or zero voltage sequences exceed given thresholds, frequency thresholds are narrowed. The system requires a suitable logic, not yet envisaged by the above mentioned national rules, to manage the frequency thresholds according to the availability of the communication system. In our experiment, the logic operates as described below:

- a. the reception of the GOOSE keep-alive message (signal #1 in Figure 8) switches the logic signal #2 to the “high” condition;
- b. the logic signal #2 stills in the “high” condition for a time equal to $1.5 T_{KA}$, where T_{KA} is the time between two consecutive keep-alive messages (e.g., 1 s);
- c. the logic signal #3 is the #2 negated: it switches to “high” if the communication system is not available (in the worst case, at least for a time equal to $1.5 T_{KA}$);
- d. in the case of hydro generators, the dotted link #4 is enabled, commanding, in the absence of the communication system, the narrowing of frequency thresholds (through “high” logic signals #4 and #5);
- e. in the case of PV generators (link #4 disabled), the absence of the keep-alive messages orders the activation of the signal #5, which enables the voltage unlock logic (inhibited in the presence of the communication system by the logic AND condition, not verified by the state “low” of signal #5).

A different approach is applied to hydro and PV generators: for hydro power plants (and, in general, rotating units), it is pivotal to minimize the risk of island operation (an out-of-sync automatic reclosing could cause serious damage to the generator), while for PV power plants it is essential to improve the continuity of service, avoiding nuisance tripping (according to Standard CEI 0-16, these DG units tolerate out-of-sync reclosings).

3.2. Logic selectivity between MV feeder protections

The FPRs developed in the Project are able to exchange IEC 61850 messages with the other protection relays on the distribution network. By means of these messages, a logic selectivity among protections is set up, improving the performance in the selection of the faulty section of the MV feeders.

The logic selectivity during a short-circuit operates as follows (Figure 9): the FPR upstream the fault detects an overcurrent (protection functions 50, 51, 67N) and sends a block message to the FPRs in the HV/MV substation. The FPR that does not receive the block message within a predetermined time commands the tripping of the relevant circuit breaker. If messages do not reach a protection relay due to problems on the always-on communication, the system operates with time selectivity.

According to this strategy, the isolation of the fault is carried out with a single maneuver, by disconnecting only the part of the network affected by the fault. Therefore, this

innovation has clear effects on the number and duration of interruptions affecting Users. Moreover, the reclosing procedure is carried out directly by the FPR that isolates the faulted section, avoiding perturbances on the upstream feeder and disconnecting only the DG underlying the tripped protection (Figure 9).

Because of the extremely short timing and high reliability required by the logic selectivity (if the upstream protection does not receive the block message within about 100 ms, the selectivity can be lost), in the Project a FO link (HV/MV substation-SaS) has been used to implement this feature.

3.3. *Experimental results*

The performance of the SG architecture in improving the reliability of IPRs and the continuity of service of Users is mainly related to the time required to exchange the messages between the apparatuses along the network's feeders (IPRs or FPRs in the Satellite Substation) and the central system (FRPs, atop of MV feeder, in the HV/MV substation).

To ensure the disconnection of an AU when the relevant FPR trips, avoiding the islanded operation of the DG and possible damages to the generator, the IPR must receive the transfer trip message sent by the FPR before its first reclosing maneuver (as already mentioned, usually performed 400/600 ms after the tripping):

$$t_T + t_{IPR} + \varepsilon_{DR} < t_{DR} \quad (1)$$

In eq. (1):

- t_T is the time needed for the transmission of the transfer trip message on the communication system;
- t_{IPR} is the time required by the IPR to detect the reception of the transfer trip message and to open the interface breaker of the relevant DG unit (e.g., 100 ms);
- ε_{DR} is a security margin against time errors (e.g., 10% of t_{DR});
- t_{DR} is the time delay set on the FPR for the first reclosing maneuver (e.g., 400 ms).

Time required by the FPR to detect the fault and begin the transmission of the transfer trip message does not appear in eq. (1) because the time delay of the first reclosing maneuver is calculated from the instant of transmission of the opening command by the FPR to the relevant circuit breaker, which is simultaneous to the instant of transmission of the transfer trip message by the FPR to the IPR.

As for the logic selectivity between the protections in the SaS and the protection atop of the relevant MV feeder, the upstream FPR must receive the inhibition message sufficiently in advance with respect to the scheduled tripping:

$$t_{DW} + t_{UP} + t_T + \varepsilon_{DT} < t_{DT} \quad (2)$$

In eq. (2):

- t_{DW} is the time required by the downstream FPR to detect the fault and to order the transmission of the inhibition message (e.g., 20 ms for the phase overcurrent function);
- t_{UP} is the time required by the upstream FPR to detect the reception of the inhibition message and to activate the logic inhibition of the protection functions (e.g., 10 ms);
- t_T is the time needed for the transmission of the inhibition message on the communication system;
- ε_{DT} is a security margin against time errors (e.g., 10% of t_{DT});
- t_{DT} is the time delay set on the upstream FPR (e.g., 100 ms), which includes the base time of the upstream relay.

Both the just mentioned SG features exploit IEC 61850 GOOSE messages to satisfy the binding time requirements for the data exchange between the relays. Therefore, from the communication system point of view, transfer trip and inhibition messages are managed exactly in the same way.

Figure 10 reports the time delay t_T for the transmission of GOOSE messages measured on the experimental SG project during May 2014 (about 240 messages). To collect a suitable amount of experimental data, the performance of the transmission system is tested continuously, by exchanging test GOOSE messages among all the protections. These signals are identical to standard messages, with the exception that they do not activate any logic function on the receiving protection.

One can observe that the time delay measured experimentally is fully compliant with the time requirements of the SG features envisaged. In detail, assuming for t_{IPR} , ε_{DR} , t_{DR} , t_{DW} , t_{UP} , ε_{DT} and t_{DT} the typical values previously mentioned, the characteristics in Figure 11(a) and Figure 11(b) are obtained. Figure 11(a) shows, according to the experimental data collected on field, an estimation of the time required for the tripping of the IPR (the time is measured starting from the instant of transmission of the opening command by the FPR to the relevant circuit breaker). Figure 11(b) shows the estimated time needed to accomplish the inhibition of the upstream FPR and to perform the logic selectivity (time measured starting from the instant of fault).

4. Voltage control

The increase of voltage profiles caused by DG power injections, which occurs in conditions of RPF [28], is a strong limiting factor for the Hosting Capacity of distribution networks. The ordinary way to adjust the voltage profiles on MV networks is to control the OLTC of HV/MV transformers. Although the recent EN 50160 [29] evolutions led to tolerate voltages on MV grids temporarily higher than 110% of the nominal value, structural interventions are often needed to allow the DG operation respecting the upper voltage limit. This causes the increase of costs and time required to connect new power plants to the grid. To ensure a faster access of RES generation to the main system, the implementation of a voltage control acting directly on DG power injections is advisable.

The control of voltage on MV/LV distribution networks by managing the active/reactive power injections of DG units and other possible regulating resources (e.g., VAR

compensators, energy storage systems, etc.) is a topic well investigated in the literature [30][31][32]. However, few experiments involving real distribution networks and real AUs are adequately documented. The “DG DemoNetz - Smart LV Grid” project [33] focuses on the voltage control on the LV grids by PV power plants. The project provides a 4 level voltage control approach involving the OLTC of MV/LV transformers, real time measurements acquired by smart meters and the reactive power management by PV converters. An alternative solution is envisaged by the project [34], coordinating a MV/LV substation, two LV feeders, some switchable capacitor banks and feeder voltage sensors, to realize a two-way centralized voltage and VAR control. No AU is involved in the experiment. In the “Smart Grid, Smart City” [35] project a similar approach is explored: supercapacitors are installed on a 33/11 kV network to adjust voltage profiles. The system, integrated with a monitoring architecture based on smart meters and sensors installed in electrical substations, is managed by the DMS in the DSO’s control center on the basis on load flow and optimizations algorithms. DG DemoNetz – Validierung [36] is a project involving MV networks. The central unit, located in the MV/LV substation, uses voltage measurements to select critical buses for the dynamic control of the transformer’s OLTC and the hierarchical DG control (4 hydro power plants).

The A.S.S.E.M. SG project proposes, as in the state-of-the-art of the literature works, a centralized approach to the voltage control. However, some important peculiarities characterize the envisaged architecture. The algorithms define the best reactive power set-points for DG units and the voltage set-point at the MV busbars of HV/MV substation based on load flow calculations. The regulation aims to maintain the voltage profiles within the 96-108% band and, at the same time, operates to avoid useless reactive absorptions/injections by DG power plants (detrimental for network losses) and to limit the number of maneuvers of the OLTC. In critical situations, when the reactive control is not sufficient to maintain the voltage profiles within the given thresholds, DG active power injections are limited according to a local logic [21]. An important aspect to point out is that the AUs have been involved in the Project on the basis of their negative effects on the network’s voltage profiles assessed during real-life operation. So, AUs with different technological characteristics (RES technology, contractual power, inverter supplier, etc.) have been selected for the integration in the SG architecture. This required to develop solutions tailored for each single situation: for example, each inverter supplier uses a different protocol interface.

As already mentioned, the control algorithm is implemented in the core unit. The proposed approach is based on two different software environments: the DMS Human Machine Interface, allowing the operator in the control center to model the network topology, and the DIgSILENT Power Factory software that computes the regulation algorithm. The two programs exchange data through the Oracle database, which stores the needed information (measurements, set-points, network structure, etc.). A scheme of the data exchanged for the voltage control is reported in Figure 12.

The voltage control procedure is performed for each busbar through a loop control with timings set by operator (e.g., two loops per minute). Each control cycle consists in the phases described in the following.

- a. Data collection. The topological model of the network (represented with buses, branches and relevant power injections) is integrated with real-time data collected on field and stored in the Oracle database (active and reactive power exchanges of

- each DG unit; voltage magnitudes in the network buses hosting DG; active and reactive power flows measured at top of each feeder and along MV lines; state of the HV/MV transformer OLTC; voltage magnitude at HV and MV busbars).
- b. State estimation. All measurements collected on field are used, together with historical data about load withdrawals and injections of DG units not included in the Project (e.g., conventional profiles), to define the voltage and active/reactive power exchanges in all the network buses. The state estimation algorithm operates with an algebraic logic, sharing the power exchanges measured at top of feeders (and, in case, those assessed along lines) among Passive and “non-smart” AUs (injections of “smart” AUs are measured) according to historical profiles. The assessment is performed on an iterative basis, converging to the solution matching the voltages measured on the grid within a fixed tolerance.
 - c. Voltage control assessment. The adjustment actions to be implemented on the grid are defined according to the voltage control algorithm described in Section 4.1.
 - d. Command transmission to the field and set-points implementation. The core unit sends the command messages to the apparatuses on field, which operate to implement them according to their internal regulation laws (ramp reactive power variation): the new set-point for the reactive power exchanges is sent to each DG unit involved in the Project, and, if the Control Law C is performed (see par. 4.1.3), the set-point of the AVR piloting the OLTC of HV/MV transformers is updated.

4.1. Voltage control algorithm

In order to manage the voltage profile over the grid, three different control logics are performed, each one implemented cyclically with a fixed timing, namely “Control Law A” (30 s), “Control Law B” (15 min) and “Control Law C” (60 min). As described below, Control Law A is the simplest one and, to limit the number of maneuvers, changes DG reactive injections and the AVR setpoint only if voltage violations are detected on the grid. Control Law B includes the capabilities of Law A; in addition, at every control cycle, it evaluates the opportunity to operate the grid in the base case, i.e. with void DG reactive injections. Control Law C performs as Law B, but optimizes also the position of the OLTC of HV/MV transformers.

4.1.1. Control Law A

The voltage control algorithm performs different actions according to the values assumed by the voltages over the network (measured, if available, or evaluated through the state estimation).

- If the voltage profiles respect predefined thresholds (96-108%), Law A does not change DG injections and the set-point of the AVR. This strategy is adopted to avoid an excessive stress of DG units and of the OLTC of HV/MV transformers (i.e., too many regulation commands).
- If a voltage violation is detected, the reactive exchanges of “smart” DG units that are required to compensate the over/under-voltages are evaluated by an Optimal Reactive Power Flow (ORPF) algorithm. In addition to the voltage limits on the grid, the algorithm takes into account the capability limits of each DG power plant and an objective function for the minimization of the total reactive power exchanged by DG units. DG reactive exchanges are minimized because the

operation with unity power factor is preferred by AUs (vice versa, the use of DG reactive injections for losses reduction is not considered).

The ORPF is based on the objective function reported in eq. (3) and is subject to two sets of constraints. The first set includes inequality constraints on maximum and minimum voltages that are measured on the network (as already mentioned, $V_{min} = 0.96$ and $V_{max} = 1.08$) and on maximum and minimum reactive powers that can be supplied by each DG unit. The second set of constraints includes the equality constraints on power flow equations, which correspond to the real and reactive power balance equations.

$$\begin{aligned}
& \min \left\{ \sum_{k=1}^M \left| Q_{opt_k} - Q_k \right| \right\} \\
& \quad \forall \text{ bus } i \\
& \quad V_i > V_{min} \\
& \quad V_i < V_{max} \\
& P_i = P_{g_i} + P_{c_i} = V_i \sum_{j=1}^N V_j (G_{ij} \cos \theta_{ij} + B_{ij} \sin \theta_{ij}) \\
& Q_i = Q_{g_i} + Q_{l_i} = V_i \sum_{j=1}^N V_j (G_{ij} \sin \theta_{ij} - B_{ij} \cos \theta_{ij}) \\
& \quad \forall \text{ DG unit } k \\
& \quad Q_{k_opt} > Q_{k_min} \\
& \quad Q_{k_opt} < Q_{k_max}
\end{aligned} \tag{3}$$

In eq. (3):

- Q_{opt_k} is the optimal reactive power required to the k -th DG unit, in order to avoid violations of the voltage limits on the network;
- Q_k is the reactive power to be injected by the k -th DG unit in the grid preferred by the User, usually equal to zero;
- M is the number of DG units performing the voltage control, equal to 9 (the LV AU 11 and the AU 2, an asynchronous generator, are not involved in the regulation);
- P_i and Q_i are the real and reactive powers injected at i -th bus of the network;
- P_{g_i} and Q_{g_i} are the real and reactive powers injected by the DG at i -th bus;
- P_{l_i} and Q_{l_i} are the real and reactive powers absorbed (negative) by the load at i -th bus;
- G_{ij} , B_{ij} , θ_{ij} are the electrical parameters of the branches of the MV network (conductance, susceptance and characteristic angle);

- N is the total number of buses of the grid.

The timing of Law A, equal to 30 s, has been defined as the minimum time (taking into account proper security margins) required to accomplish the whole control cycle (data collection, state estimation, voltage control assessment, command transmission to the field and set-points implementation). A limit to the adoption of faster regulating frequencies is imposed by conventional generation units (i.e., hydro DG): their electromechanical regulators usually require a significant amount of time to implement the set-point on the generator (in the project, DG units are already installed in the grid and some generation units are quite old).

4.1.2. Control Law B

Control Law B, activated every 15 min, performs the same control actions provided by the Law A, with the exception that at every control loop it verifies the possibility of operating the system in the condition of void DG reactive power exchanges (Law A performs this evaluation only in the presence of voltage violations). This is achieved through the ORPF objective function, minimizing the reactive power exchanges of “smart” DG power plants. The algorithm takes into account the measured DG active injections, the actual position of the OLTC of the HV/MV transformer and the load data provided by the state estimation. Control Laws A and B needed to be differentiated in order to limit the stress to which DG power plants are exposed: the timing and number of control actions imposed by the Law A, in fact, could cause a premature aging of DG units components (especially in the case of conventional DG power plants), resulting in an undesirable shortening of the lifespan. Therefore, Control Law A changes DG reactive set-points only when strictly necessary (voltage violation), while Law B acts on DG set-points both to solve voltage violations and to optimize (to reduce) reactive power exchanges.

4.1.3. Control Law C

Control Law C realizes the voltage control identifying, every hour, also a suitable set-point for the AVR piloting the OLTC of the HV/MV transformer. Based on the data provided by the state estimation algorithm, a set of load flow calculations is performed. Each load flow calculation differs from the other for the voltage set-point at the MV busbars (the logic simulates the network behavior with 0.5% set-point variations). The reactive injections of “smart” DG units are assumed void. The algorithm selects the MV busbars set-point and DG reactive injections with the purpose to obtain a voltage profile within the allowed range. If at least one set-point meets the requirements, the one to be adopted is selected according to a minimum least square algorithm [37], assessing the gap between the voltage on all the N network buses (V_i) and a reference value (V_{ref}):

$$\min \left\{ \sum_{i=1}^N (V_i - V_{ref})^2 \right\} \quad (4)$$

The reactive exchanges of DG units are set to zero. If acceptable voltage levels cannot be achieved acting only on the OLTC, the set-point of MV busbars is set to the value

minimizing the voltage violations and a regulation process using ORPF calculations (as done by Control Law B) is performed.

The time schedule to optimize the OLTC position (60 min) has been defined to provide a suitable tradeoff between the number of daily AVR maneuvers and the necessity to ensure an adequate compensation, through the AVR control, of voltage variations at MV busbars. To this purpose, experimental data were exploited, to evaluate the best solution according to the actual load/generation profiles and the electrical parameters of the distribution network (e.g., short-circuit power at MV busbars).

4.2. Experimental assessment of the benefits of the voltage control

In this section, a numerical assessment of the benefits of the voltage control developed in the Project is carried out. To this purpose, a Nodal Hosting Capacity approach is adopted [38]: i.e. the maximum generation capacity that can be installed on the MV grid without exceeding the technical voltage constraints is evaluated in each bus of the network. Two different scenarios are studied, taking into account the different DG voltage control capabilities before and after the implementation of the Project. In the first scenario, no voltage control is performed and all DG units operate with a power factor equal to 1. In the second scenario, the SG architecture enables the voltage control through the DG units: if needed, the DG power plants can absorb/inject reactive power (up to a power factor 0.9 leading/lagging).

The analysis is performed on a model of the A.S.SE.M. MV network developed according to the method detailed in [2]. The MV/LV loads and generators are introduced in the model as equivalent power exchanges at the network's buses. All the energy flows in the grid (power withdrawals of MV/LV passive Users and power injections of MV/LV AUs) are represented on an hourly basis and over a whole year (8760 h). Each AU involved in Project is assigned the profile of power production actually measured on the power plant during the period May 2013 – April 2014. The power exchanges of the other Users are obtained sharing the profiles measured in HV/MV substation proportionally to Users' contractual power.

According to the just mentioned hypotheses, and considering for the voltage profile a limit of 108% of the rated value, the results reported in Figure 13 are obtained. The figure shows the percentage of network buses that are able to accept the amount of DG reported on the x-axis, without (white) and with (gray) the voltage control. The plot highlights that the voltage regulation through the DG units allows a substantial improvement of the Hosting Capacity of the network: for example, by controlling the reactive DG injections, about 98.2% of the network buses can host 2 MW of DG, while before the implementation of the Project only 79.8% of buses were compliant with that amount of generation. Similar results are achieved for greater amounts of Hosting Capacity. Considering the maximum DG size that the Italian connection rules require to be installed on the MV level, equal to 6 MW, the voltage control increases the percentage of buses compliant with such DG amount from 59.63% up to 66.97%.

5. Conclusion

The paper presented the architecture and the main features provided by the Smart Grid pilot project in charge to A.S.SE.M. SpA, incentivized by the Italian Energy Authority according

to Res. ARG/elt 39/10. The purpose of the Project is to test in a real scenario the main functionalities required to face with the RES impact on a real life distribution network. Among the experimented features, the control of the IPR of AUs by transfer trip and keep-alive messages will ensure the reliable and effective management of DG units underlying distribution grids, even during faults and perturbations on the HV system. The logic selectivity among FPRs will allow the DSO to limit the impact of faults on Users' continuity of service, while the centralized voltage control performed by DG will increase the amount of generation acceptable by the grid without investments for new assets. Moreover, the opportunity to monitor in real-time and to shed, if necessary, the DG production will help the TSO/DSO to manage contingencies and to operate more efficiently the whole power system.

Experimenting and assessing on field the just mentioned features is essential in the perspective of a full scale deployment of Smart Grids. From this point of view, San Severino Marche has proven to be an ideal context for testing the solutions developed by the theoretical research activity: it is a real life scenario, involving an electricity distribution network actually in operation, with real Active and Passive Users. In authors' opinion, in fact, the collection of information about the practical SG applicability (e.g., integration of the architecture in the existing infrastructure and control system), its economic feasibility and the impact of new procedures on the TSO/DSO routines and on Users behavior, is essential for addressing an effective deployment of Smart Grids.

Bibliography

- [1] A. Pecas Lopes, N. Hatziargyriou, J. Mutale, P. Djapic, N. Jenkins, Integrating distributed generation into electric power system: A review of drivers, challenges and opportunities, *Electr. Power Syst. Res.* 77 (2007) 1189-1203.
- [2] M. Delfanti, D. Falabretti, M. Merlo, Dispersed generation impact on distribution network losses, *Electr. Power Syst. Res.* 97 (2013) 10-18.
- [3] M. Delfanti, D. Falabretti, M. Merlo, G. Monfredini, V. Olivieri, Dispersed generation in MV networks: Performance of anti-islanding protections, 14th International Conference on Harmonics and Quality of Power (ICHQP), Bergamo, Italy, 1-6, 26-29 Sept. 2010.
- [4] ENTSO-E Network Code for Requirements for Grid Connection Applicable to all Generators, 2012.
- [5] M. Delfanti, D. Falabretti, M. Merlo, G. Monfredini, L. Pandolfi, AlpStore project: a viable model for renewables exploitation in the Alps, *Energy Procedia*, 46 (2014) 3-12.
- [6] Strategic deployment document for Europe's Electricity Networks of the Future, European Smart Grids Technology Platform report, 2010.
- [7] Horizon 2020, <http://ec.europa.eu/programmes/horizon2020/>, 2014.
- [8] OFGEM Low Carbon Networks Fund, <https://www.ofgem.gov.uk/electricity/distribution-networks/network-innovation/low-carbon-networks-fund>, 2014.
- [9] Procedures and criteria for the selection of investments admissible for incentives pursuant to paragraph 11.4, letter d) of Annex A to Authority for Electricity and Gas Resolution No. 348/07 of 29th December 2007, Resolution ARG/elt 39/10, 2010.
- [10] The European Electricity Grid Initiative, Roadmap 2010-18 and Detailed Implementation Plan 2010-12, March 2010.
- [11] AEEG: site of Smart Grid pilot projects supported by Res. ARG/elt 39/10, <http://www.autorita.energia.it/it/operatori/smartgrid.htm>, 2014.
- [12] Evaluation and ranking of pilot projects for active networks and smart grids proposed according to the Resolution ARG/elt 39/10 of the Italian Energy Authority (25 March 2010),

- Resolution ARG/elt 12/11, 2012.
- [13] Communication networks and systems in substations, Standard IEC 61850, 2013.
 - [14] DIGSILENT, <http://www.digsilent.de/>, 2014.
 - [15] Oracle, <http://www.oracle.com/>, 2014.
 - [16] PREMIO: a smart-grid demonstration project, <http://researchers.edf.com/research-activities/networks/premio-a-smart-grid-demonstration-project-44255.html&return=44250>, 2014.
 - [17] W. Wang, Y. Xu, M. Khanna, A survey on the communication architectures in smart grid, *Computer networks* 55 (2011) 3604-3629.
 - [18] S. Botton, L. Cavalletto, F. Marmeggi, Schema Project – Innovative criteria for management and operation of a closed ring MV network, CIRED 2013, Stockholm, 10-13 June 2013.
 - [19] IDE4L project Deliverable 2.1: Specification of Active Distribution Network Concept, April 2014.
 - [20] ENTSO-E Network Code for Requirements for Grid Connection Applicable to all Generators, 2012.
 - [21] Reference technical rules for the connection of active and passive consumers to the HV and MV electrical networks of distribution company, Standard CEI 0-16 III ed., 2012.
 - [22] Reference technical rules for the connection of active and passive users to the LV electrical Utilities, Standard CEI 0-21 II ed., 2012.
 - [23] Technical rules of the system requirements of the Dispersed Generation, Annex A.70 to the Terna Grid Code, 2012.
 - [24] Procedure for the reduction during emergency conditions of the Dispersed Generation connected to the National Power System, Annex A.72 to the Terna Grid Code, 2012.
 - [25] H. Shayeghi, B. Sobhani, Zero NDZ assessment for anti-islanding protection using wavelet analysis and neuro-fuzzy system in inverter based distributed generation, *Energ. Convers. Manage.* 79 (2014) 616-625.
 - [26] A. Cerretti, E. De Berardinis, G. Monfredini, M. Merlo, M. Delfanti, Dispersed Generation in MV networks: reliability of passive anti-islanding protection methods, CIRED, Frankfurt, 6-9 June 2011.
 - [27] EPRI Smart Grid Demonstration Initiative – 5 Year Update, 2013.
 - [28] M. H. Bollen, F. Hassan, *Integration of Distributed Generation in the Power System*, Wiley, 2011.
 - [29] Voltage characteristics of electricity supplied by public distribution networks, Standard EN 50160, 2010.
 - [30] T. Xu, N.S. Wade, E.M. Davidson, P.C. Taylor, S.D.J. McArthur, W.G. Garlick, Case-based reasoning for coordinated voltage control on distribution networks, *Electr. Power Syst. Res.* 81 (2001) 2088-2098.
 - [31] V. Calderaro, G. Conio, V. Galdi, A. Piccolo, Reactive power control for improving voltage profiles: A comparison between two decentralized approaches, *Electr. Power Syst. Res.* 83 (2012) 247-254.
 - [32] Alfredo Vaccaro, Giovanni Velotto, Ahmed F. Zobaa, A Decentralized and Cooperative Architecture for Optimal Voltage Regulation in Smart Grids, *IEEE Trans. Ind. Electron.* 58 (2011).
 - [33] A. Einfalt, F. Kupzog, H. Brunner, A. Lugmaier, Control Strategies for Smart Low Voltage Grids – The Project DG DEMONET – Smart LV Grid, CIRED Workshop, Lisbon, 29-30 May 2012.
 - [34] G. Yuan, B. Deaver, R. Davis, K. Bloch, T. Yohn, R. Webb, K. McBee, The Functionalities and Benefits of a Two-Way Centralized Volt/VAR Control and Dynamic Voltage Optimization, *Business Wire*, 2010.
 - [35] Ausgrid Smart Grid, Smart City project, <http://www.smartgridsmartcity.com.au/>, 2014.
 - [36] DG DemoNetz - Validierung project, <http://www.igreengrid-fp7.eu/scope-of->

- work/demonstrators/austria/dg-demonetz-valideierung.aspx, 2014.
- [37] A. Zobian, M. Ilíc, A steady state voltage monitoring and control algorithm using localized least square minimization of load voltage deviations, IEEE Trans. Power Syst. 11 (1996) 929-938.
- [38] M.H.J. Bollen, Y. Yang, F. Hassn, Integration of Distributed Generation in the Power System – A Power Quality Approach, 13th International Conference on Harmonics and Quality of Power, Wollongong, NSW, Sept. 28 2008.

Tables

Active User	Technology	Voltage Level	Contractual Power [kW]	Communication Technology
AU 1	Run-of-the-river hydro	MV	860	Fiber Optic
AU 2	Run-of-the-river hydro	MV	330	Mobile Network + Wi-Fi (in series to Fiber Optic)
AU 3	PV	MV	2309	Mobile Network + Wi-Fi (in series to Fiber Optic)
AU 4	PV	MV	1700	Fiber Optic
AU 5	PV	MV	900	Fiber Optic
AU 6	PV	MV	900	Fiber Optic
AU 7	PV	MV	900	Fiber Optic
AU 8	PV	MV	900	Fiber Optic
AU 9	PV	MV	850	Mobile Network + Wi-Fi (in series to Fiber Optic)
AU 10	PV	MV	850	Mobile Network + Wi-Fi (in series to Fiber Optic)
AU 11	PV	LV	99	Mobile Network

Table 1. Active Users involved in the Smart Grid experiment.

HV/MV substation	Active Users
<ul style="list-style-type: none"> • SCADA/DMS unit, providing the conventional SCADA/DMS features and the novel Smart Grid functionalities described in Section 2. • Feeder Protection Relays (FPRs), which send transfer trip messages to the DG units underlying (both the protections atop of MV feeders and the protections on the MV side of HV/MV transformers are equipped with innovative FPRs); • Protection Relays (PRs) on the HV side of the substation (protection of HV busbars; protection on the HV side of HV/MV transformers), which are monitored in order to avoid the island operation of the MV grid (see Section 3); • Bay Control Unit (BCU), that realizes, through a wired interface, the monitoring and control of non-IEC 61850 devices (protection panel of MV capacitors, substation monitoring panel, protection panel of the MV busbars connector); • Automatic Voltage Regulator (AVR), which pilots the On-Load Tap Changer (OLTC) of 	<ul style="list-style-type: none"> • Interface Protection Relay (IPR) of the DG power plant, able to receive transfer trip and keep-alive messages from the upstream FPR (see Section 3). • User Exchange Meter (UEM) and DG Production Meter (DGPM): the already existing meters can be used to this purpose, if a serial port is available; as an alternative, dedicated meters must be put in place. • Processing Unit, that allows the monitoring and control of the switch disconnectors and fault detectors on the MV line, the acquisition of the voltage measurements at the MV busbars of the MV/LV substation (by a dedicated VT or, in the case of substations underlying AUs, by the VT of User's meters), the control of DG active and reactive injections (acting through ModBus protocol on the DG Controller) and the metering data acquisition (active and reactive power) by ModBus protocol. • DG Controller (DGC), which actuates the set-point of reactive power on the generator and, if needed, the active power limitation command received from the core unit in the HV/MV

<p>HV/MV transformers according to the voltage control algorithm;</p> <ul style="list-style-type: none"> • Data Acquisition System, which collects, by Voltage and Current Transformers (VTs and CTs), the voltages assessed on the HV/MV busbars and the currents measured atop of feeders (and on HV/MV transformers); • Power Quality Meters (PQMs), monitoring the voltage and current on the MV side of the substation for ex-post evaluations (e.g., benefits of the Project on the quality of service indices, transient analyses). 	<p>substation.</p> <ul style="list-style-type: none"> • Fault Passage Indicator (FPI), which provides an indication of the presence of a fault on the feeder downstream of the relevant MV/LV substation, allowing the implementation of fault clearing procedures. • Router/switch acting as interface between the devices displaced in the AU's site (or in MV/LV substation) and the communication system (FO, Wi-Fi, 3G) towards the HV/MV substation.
--	--

Table 2. Main components of the SG architecture.

Technology	HV/MV Substation		Active Users & Satellite Substation	
	Investment cost	Yearly charge	Investment cost	Yearly charge
Fiber Optic	€8.600	-	€4.500	-
Wi-Fi	€1.500	-	€800	-
3G	€15.800	€7.000	€2.200	€250
Total	€25.900	€7.000	€7.500	€250

Table 3. Costs estimated for the communication system.

Fiber Optic	Wi-Fi	3G
<p>FO for overhead lines</p> <ul style="list-style-type: none"> • All-Dielectric Self-Supporting (ADSS) FO cable (maximum span 350 m) with double Polyethylene coating. • 24 single-mode fibers, ITU-T G652.D 9/125 μm. <p>FO for underground lines</p> <ul style="list-style-type: none"> • All-Dielectric FO cable with double Polyethylene coating. • 24 single-mode fibers, ITU-T G652.D 9/125 μm. 	<ul style="list-style-type: none"> • Technology Layer 2 IEEE 802.11n (up to 300 Mb/s). • Transmission frequency: 2.4/5.4 Ghz. • PoE power supply. • \varnothing60 cm 24 dBi High-Gain directive antennas (up to 15 km), supply power 10 W. 	<p>HV/MV substation wired-connection</p> <ul style="list-style-type: none"> • Symmetric High-bit rate Digital Subscriber Line (SHDSL). • Transmission rate: 2 Mbit. • Minimum transmission rate: 1 Mbit. <p>AUs mobile connection</p> <ul style="list-style-type: none"> • High-Speed Downlink Packet Access (HSDPA) technology. • Transmission rate: 2 Mbit. • High-gain UMTS 13 dBi directional antenna.

Table 4. Main characteristics of the communication system.

Figures

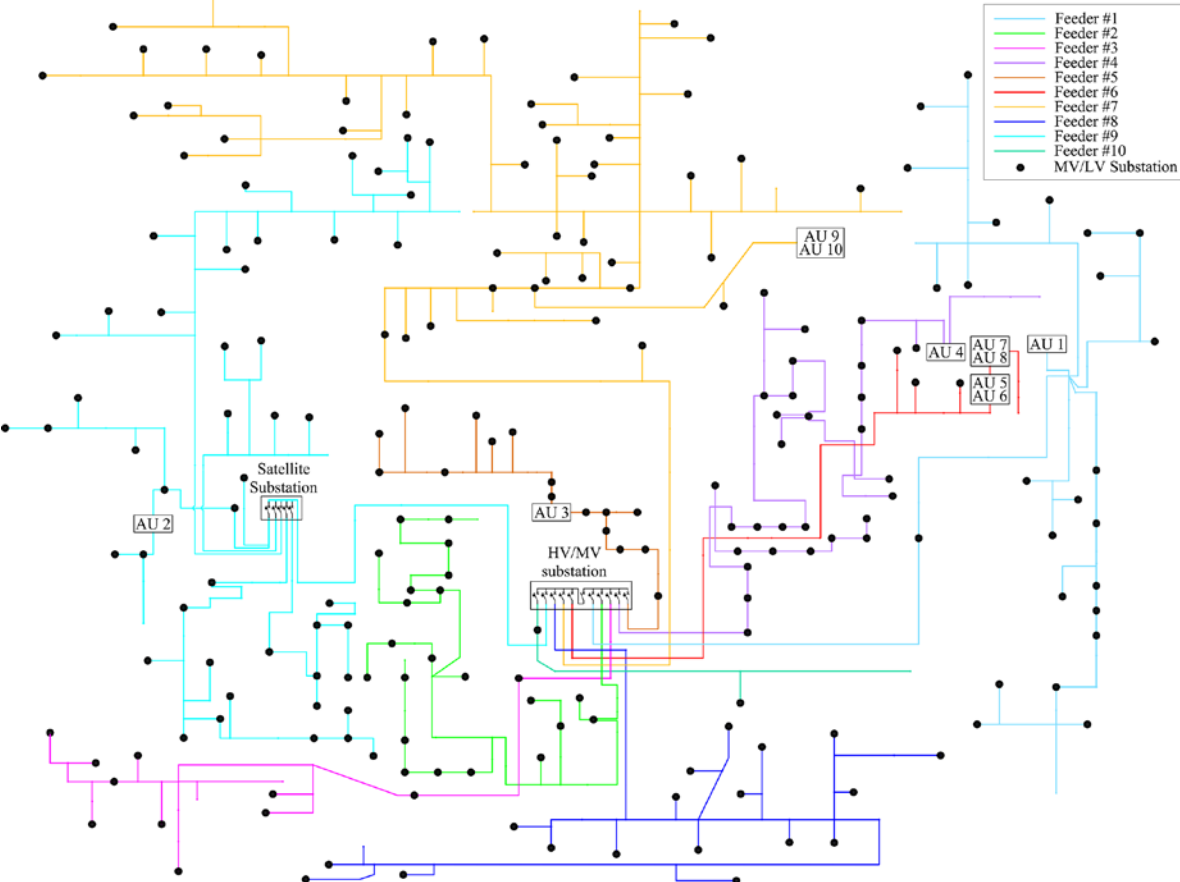

Figure 1. The MV distribution network (20 kV) involved in the Project.

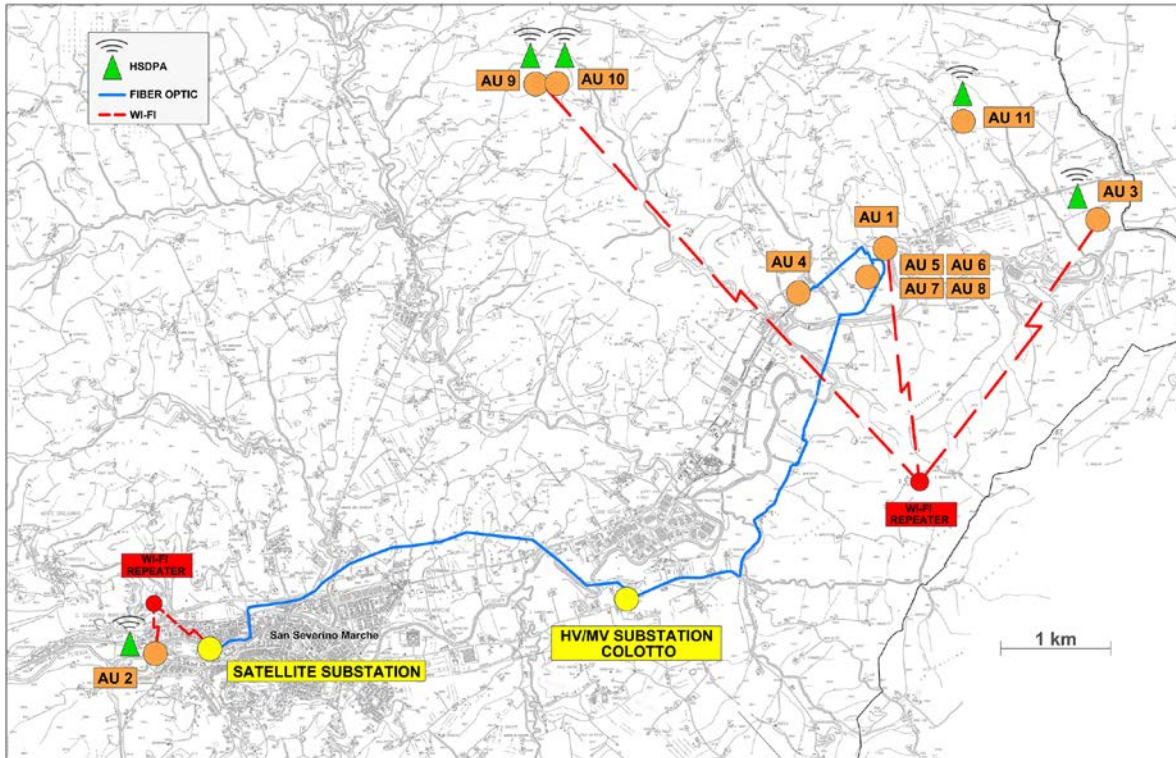

Figure 2. Communication system of the SG project.

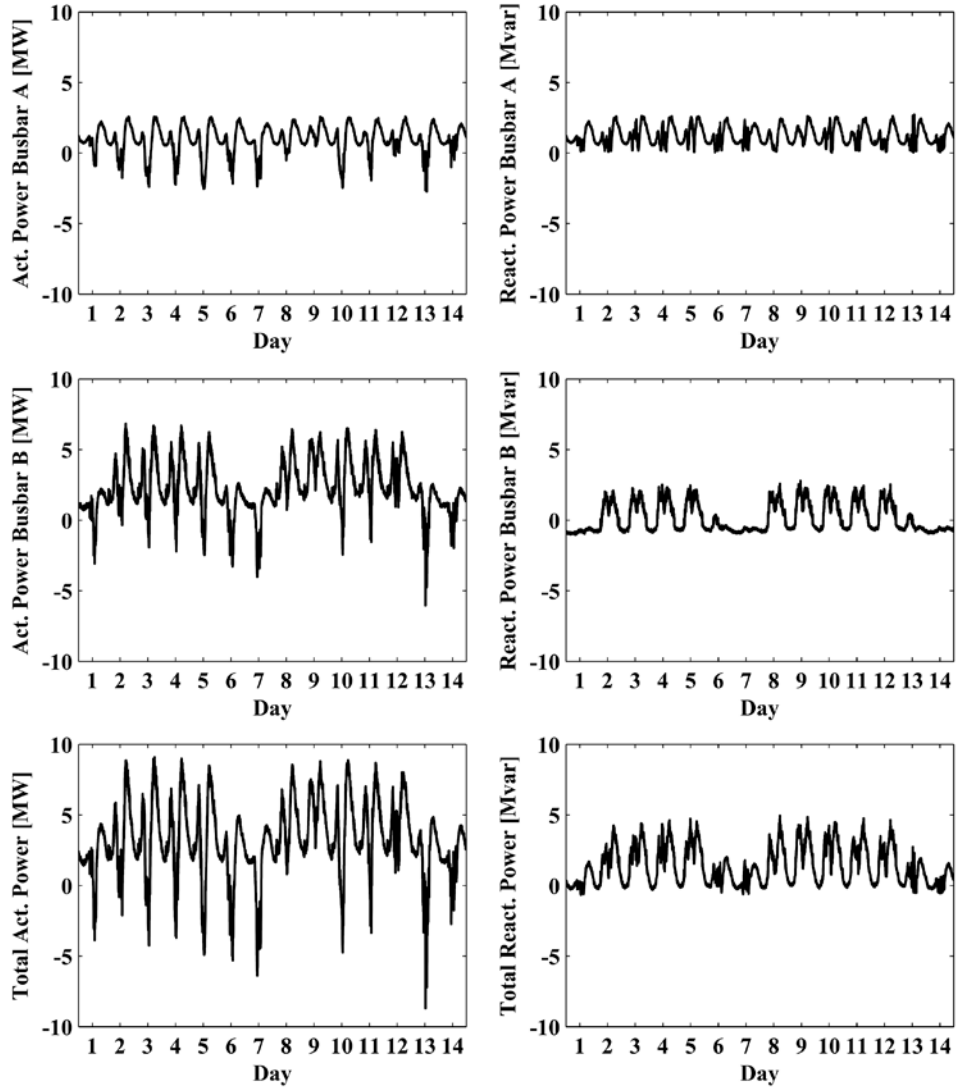

Figure 3. Active and reactive power withdrawals measured at the HV interface of the A.S.SE.M. substation during the period 6 - 19 January 2014.

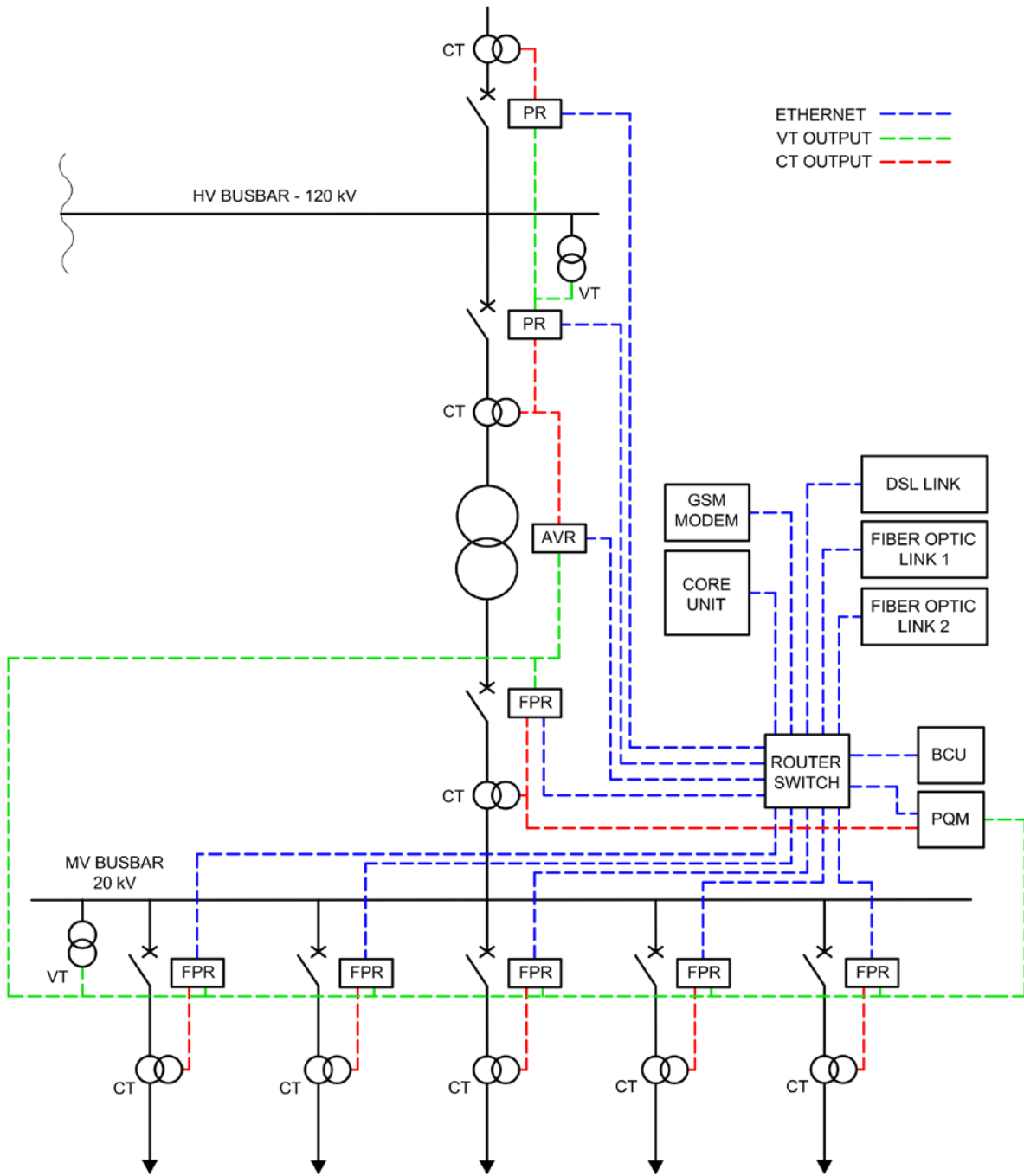

Figure 4. Functional architecture of the Smart Grid system for a MV busbar of the HV/MV substation.

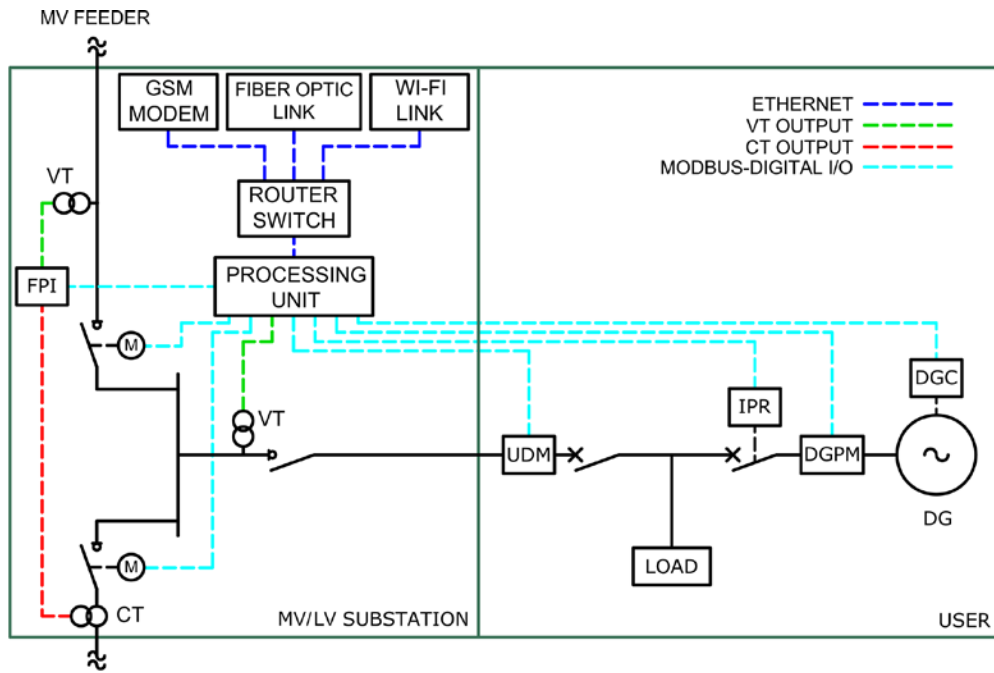

Figure 5. Functional architecture of the system for Active Users.

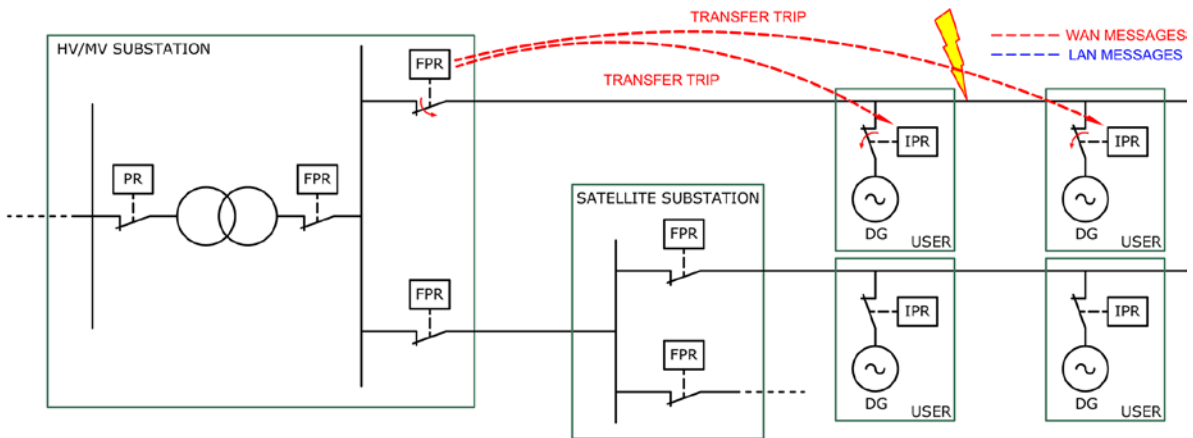

Figure 6. Transfer trip message sent to the DG units underlying a distribution feeder.

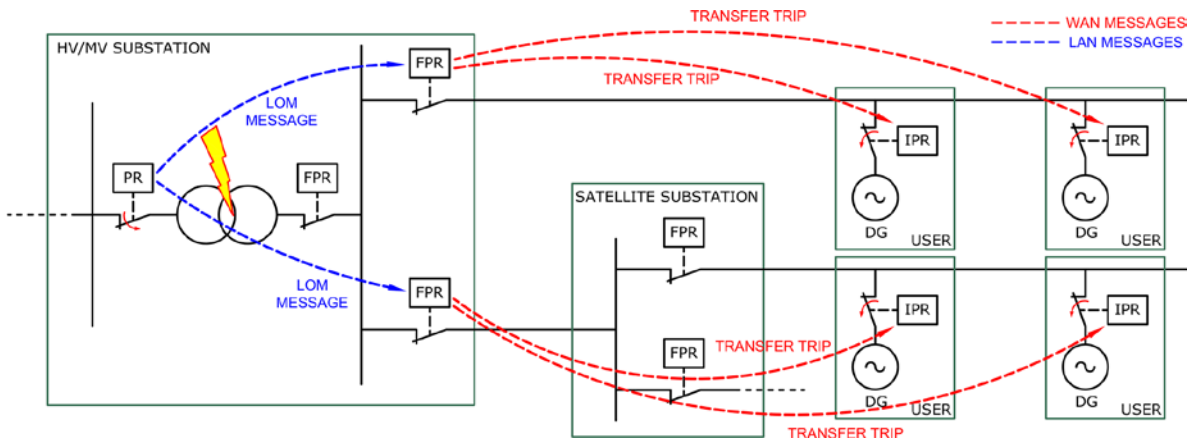

Figure 7. Transfer trip message in case of tripping of a HV protection relay.

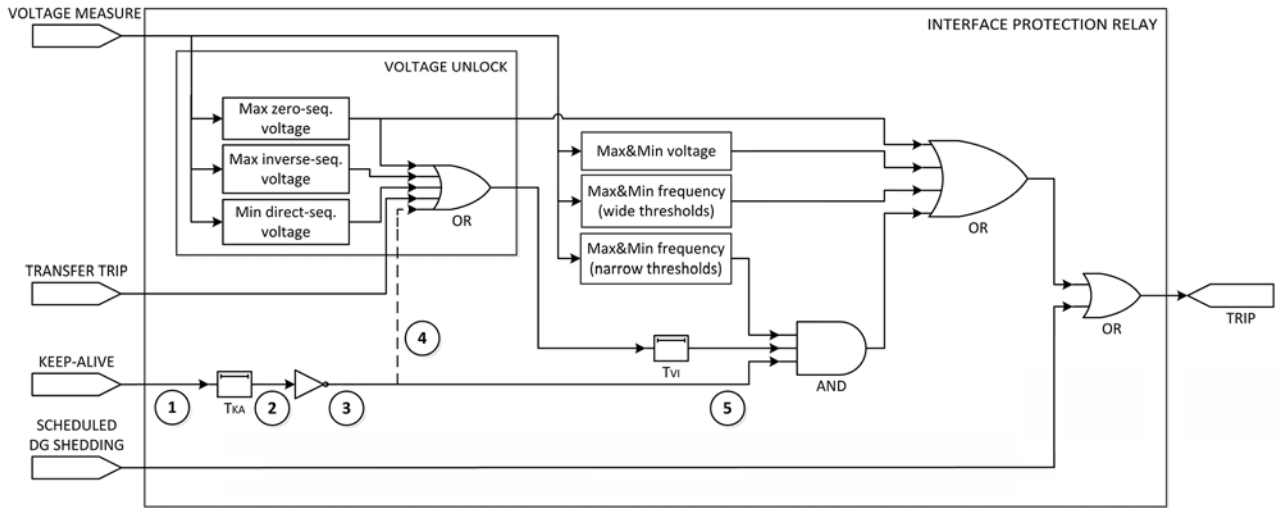

Figure 8. The logic implemented on Active Users' IPRs.

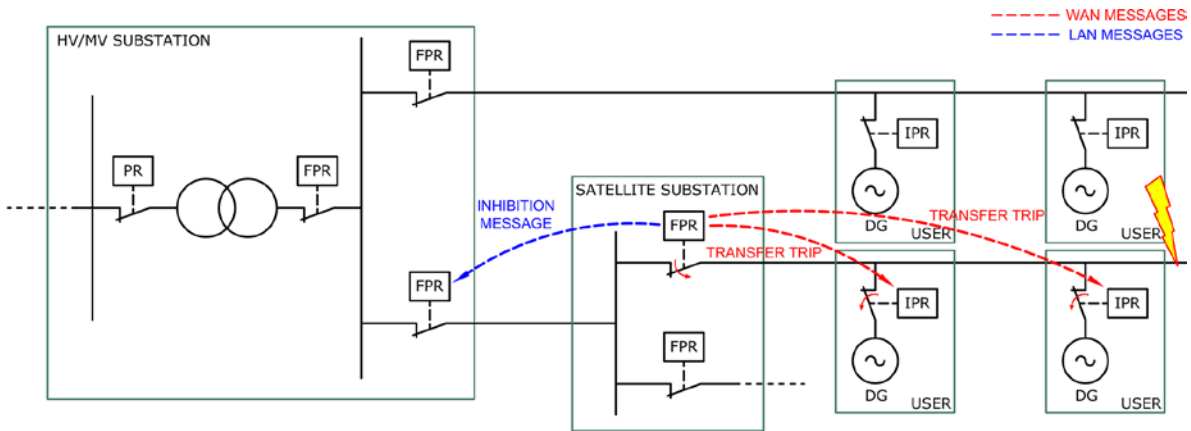

Figure 9. Automatic reclosing with logic selectivity.

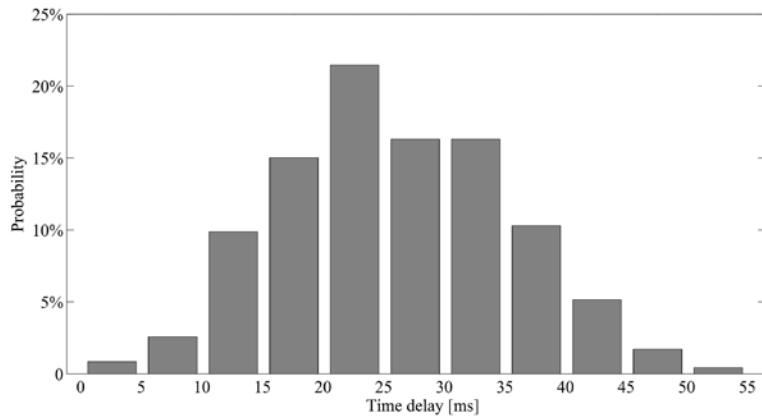

Figure 10. Probability density function of the time delay for the transmission of GOOSE messages.

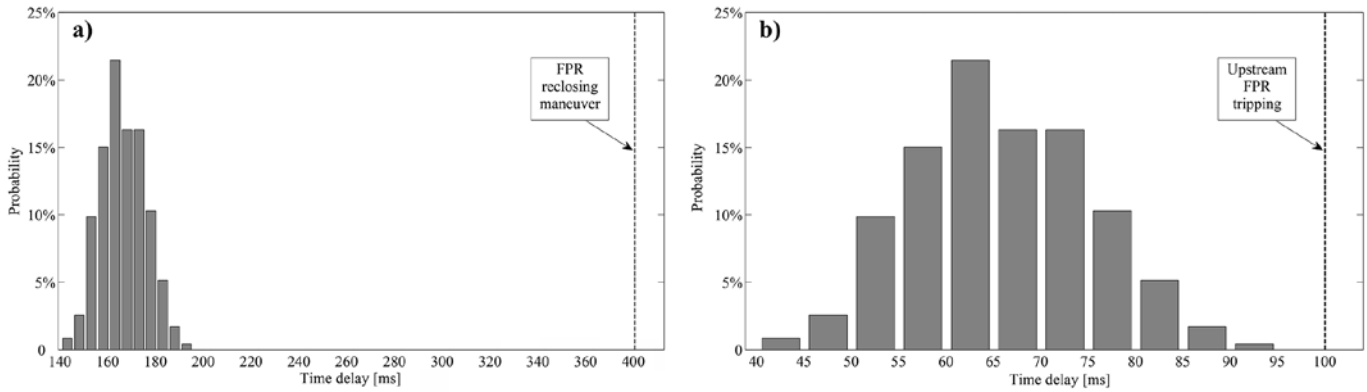

Figure 11. Estimated time for the IPR tripping (a) and the FPR inhibition (b).

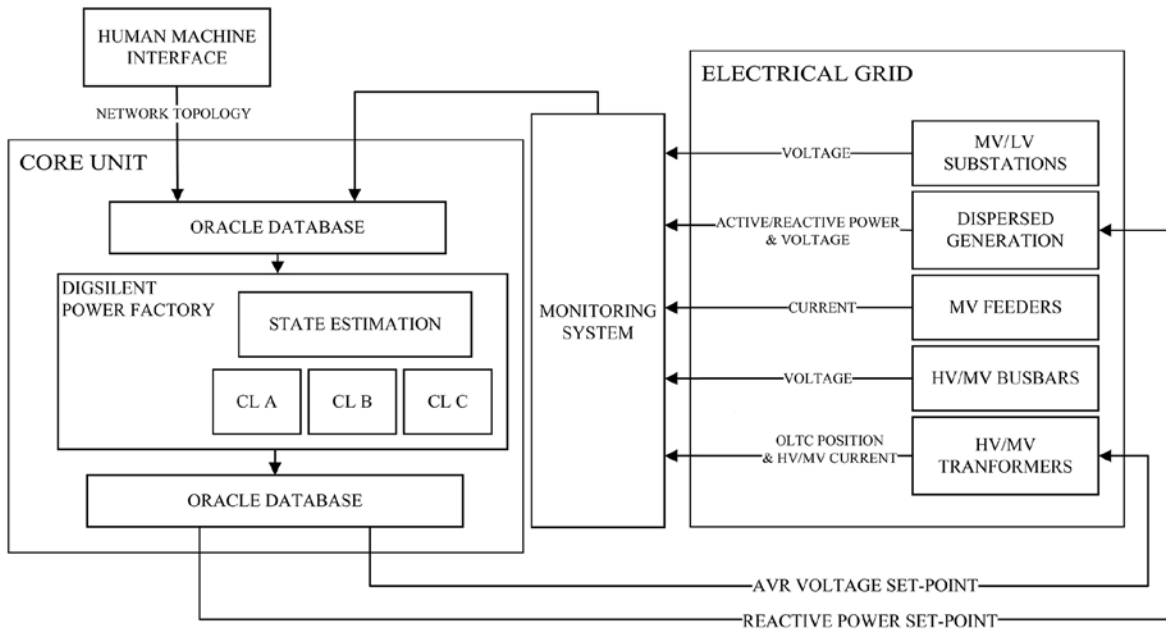

Figure 12. Data exchanged to perform the voltage control on the MV network.

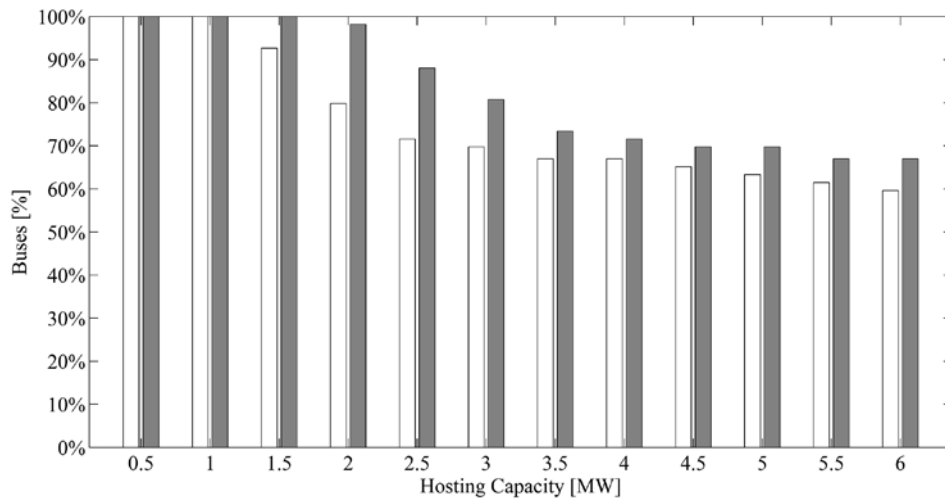

Figure 13. Nodal Hosting Capacity on the MV grid before (white) and after (gray) the SG project.