

Energy and Economic Analysis of a New Low-Temperature Distillation Process for the Upgrading of High-CO₂ Content Natural Gas Streams

Stefano Langè^{a}, Laura A. Pellegrini^a, Paolo Vergani^b, Marco Lo Savio^b*

^aDipartimento di Chimica, Materiali e Ingegneria Chimica “G. Natta”, Politecnico di Milano,
Piazza Leonardo da Vinci 32, I-20133 Milano, Italy

^bTecnimont S.p.A., Via G. De Castilia 6a, I-20124 Milano, Italy

An energy and economic analysis on a new distillation process for the upgrading of high-CO₂ content natural gas streams has been carried out. The process has been optimized by means of a feed splitting technique to minimize the energy requirements. The performances of the process have been compared to the ones of a traditional MDEA scrubbing process in terms of energy expenses. The cost of energy has been quantified to build up a merit index function, which allows to determine the trade-off between the two technologies as a function of the CO₂ and H₂S content in the feed gas and the geographic area where the gas reserve is located. The results have been discussed on the basis of the cost of energy in different geographic areas, showing the benefits (in terms of energy and operating costs savings) of a low-temperature distillation process when the CO₂ content in the natural gas streams is high.

1. Introduction

The global energy demand is expected to grow rapidly in the next twenty years. Primary energy consumption is expected to rise by 41% in 2035, with a great contribution coming from growing emerging economies.

Among fossil fuels sources, natural gas is expected to have the most rapid growth¹.

Data reported in open literature show that the 40% of the remaining reserves are sour and a huge part of these gases has a CO₂ content higher than 10%^{2,3}.

These kinds of natural gas reservoirs are distributed worldwide in a lot of the most important economic areas, such as USA, Middle East, Asia-Pacific and Europe³.

In this scenario industries need to find technologies to allow the profitable exploitation of such a kind of low quality and high CO₂ content gas reserves, in order to meet the increasing energy demand, while decreasing the production costs.

Low-temperature processes are preferred to traditional chemical or physical absorption for gas purification⁴ when the carbon dioxide concentration in natural gas streams is high. Examples of applications of low temperature gas purification processes applied to the natural gas industry are the CFZ process⁵⁻¹⁰, the Ryan-Holmes process¹¹⁻¹³, the antisublimation process¹³ and, recently, a new process based on dual pressure distillation¹⁵.

Low-temperature technologies can be also applied to post-combustion carbon capture, syngas purification¹⁶ and biogas upgrading¹⁷. In recent years the attention on low temperature processes for carbon dioxide removal has increased.

In this work an economic analysis has been carried out to determine the trade-off between classical MDEA gas sweetening units and a low temperature distillation process¹⁵ for the purification of natural gas, considering different possible CO₂ and H₂S concentrations in the gas

feed. The comparison has been carried out in terms of energy operating expenses for the two processes. The MDEA unit typically requires steam at the reboiler of the regeneration column, while the low temperature distillation processes consume electric energy to drive the refrigeration cycle. In amine regeneration units, the steam consumption is a significant part of the total energy demand of the process and, so, of the total operating costs. Typically the regeneration of the solvent covers the 80% of the total energy consumption in amine scrubbing processes¹⁸. For low temperature distillation processes, the electric requirement of the refrigeration cycle plays the most significant role.

A merit index function has been built to determine the trade-off between the two considered technologies.

Data about cost of natural gas and electricity have been found in literature¹⁹⁻²² and the cost of steam has been estimated starting from the price of natural gas and electricity to drive industrial boilers.

2. Description of the low temperature distillation process

The low temperature distillation process has been simulated using Aspen Hysys v7.3[®]. The base scheme and a modified one have been studied to determine the effect of the feed splitting technique applied to the feed of the low pressure section²³ on the overall cooling energy requirements. The two process flow diagrams are presented in Fig. 1.

a)

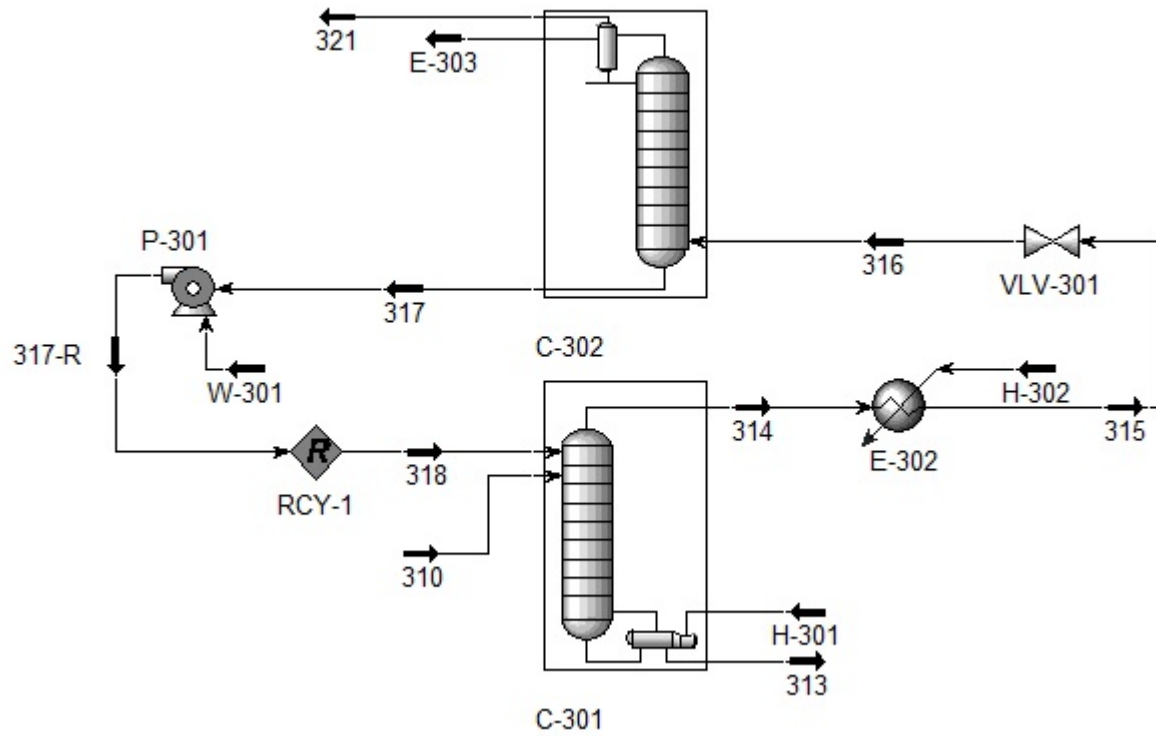

b)

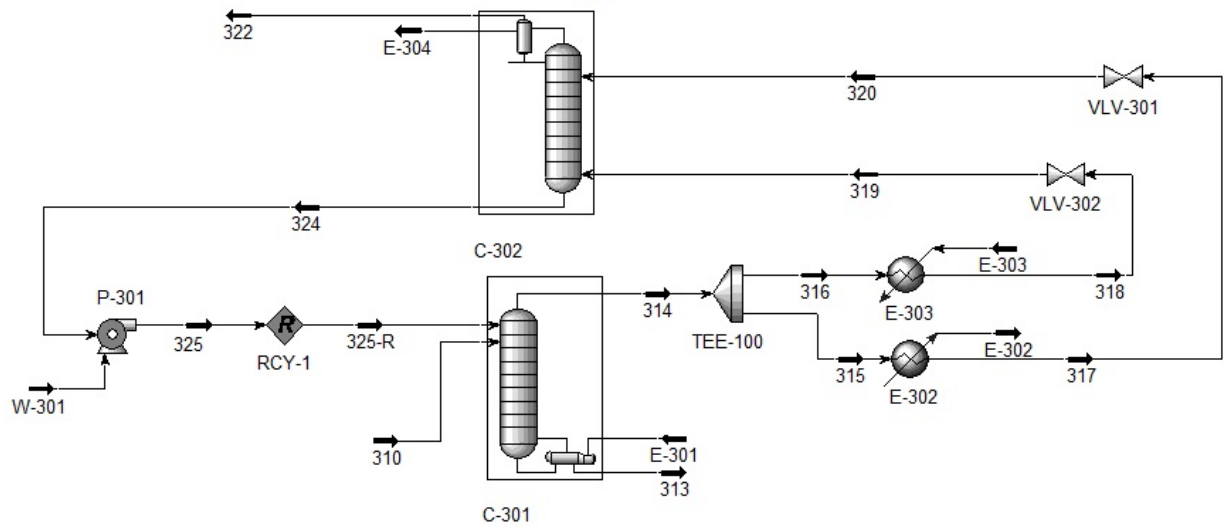

Figure 1. Process flow diagrams for the low temperature distillation process. a) base scheme, b) modified scheme with the feed splitting technique.

In both process configurations the high pressure column (C-301) is operated at 50 bar, while the low pressure distillation column (C-302) at 40 bar. The natural gas stream 310 enters the process at its dew point conditions at 50 bar. Stream 313, the bottom of the high pressure section, contains mainly CO₂, while the top product stream 314 from C-301 contains methane and typically less than 6 mol% of CO₂. In the base scheme (Fig. 1a), the C-301 top gas stream is heated to obtain a superheated gas stream (316) after the expansion valve. The level of superheating above the dew point is chosen between 5-6 K to avoid solid CO₂ formation. In the modified process solution (Fig. 1b), the top C-301 gas stream is divided into two streams (316 and 315). Stream 316 is heated and expanded as in the base scheme (Fig. 1a), while the stream 315 is cooled at 50 bar and expanded to its bubble point at 40 bar. Stream 319 is fed at the bottom of C-302 while stream 320 is fed at an upper tray. The top product stream from the low pressure distillation section is mainly methane, while the bottom liquid stream is methane and less than 8 mol% of CO₂. This stream is then pumped back to C-301. In the modified process, the feed splitting ratio is decided to keep the concentration of CO₂ in the bottom liquid stream from C-302 lower than 8 mol% in order to avoid solid formation. In the base scheme, this effect is controlled by the reflux ratio of C-302, that is typically higher than the one obtainable in the modified scheme. A more detailed description of the two configurations can be found elsewhere¹⁵.

3. Description of the case studies for the low-temperature distillation process

To cover a large range of interest in terms of possible acidic gases contents in the natural gas stream and to extend the field of the economic analysis to different gas compositions, process simulations have been performed considering as gas feed binary mixtures of CH₄-CO₂ and ternary mixtures containing also H₂S. The considered molar flow rate of the feed is 5000 kmol/h

at its dew point at 50 bar. It has to be noticed that this condition can be reached by the recovery of cold energy from the C-302 top product gas, which is available at temperatures of about -95 °C. The inlet mole fraction of carbon dioxide has been varied of 5 mol% from 5 up to 65 mol%. At the same time the H₂S molar fraction in the gas feed has been varied of 5 mol% from 0 to 15 mol%. The content of methane in the bottom product stream of C-301 has been fixed at 0.01 mol%, to enhance the methane recovery. For the top product stream the maximum allowable content of carbon dioxide is 2 mol%^{7,24}. From regulation, the maximum allowable content of H₂S in pipeline-quality gas is 4 ppm²⁵. Since in this work hydrogen sulfide has been considered representative of all the sulfur species, for the case studies its limiting value in the produced gas has been considered 10 ppm, the maximum allowable value for personnel protection²⁶⁻²⁷. To avoid the freezing of CO₂ in the process, its content at the outlet of the LP section (C-302) cannot be higher than 8 mol%. In the first part of the work, the cooling duty requirements for the base (Fig. 1a) and the optimized process layouts (Fig. 1b) have been compared to determine the positive effect of the introduction of the feed splitting technique²³ in terms of energy savings. The base and the optimized process configurations have been simulated according to the patent¹⁵.

4. Description of the MDEA purification unit

The MDEA purification unit has been considered as reported in Figure 2. The gas feed stream is fed to the absorption column, where it is contacted countercurrently with the lean MDEA solution. The purified gas stream is obtained at the top of the absorber and a rich liquid stream at the bottom, containing contaminants to be removed. The rich stream is then flashed to low pressure, heated in the intermediate heat exchanger and sent to the regeneration column, where acidic gases are stripped from the solvent and obtained as gas at the top, while the lean

regenerated solvent is recovered at the bottom of the regeneration column. Typically reboiler temperatures cannot exceed 127 °C to avoid the thermal decomposition of the solvent²⁸.

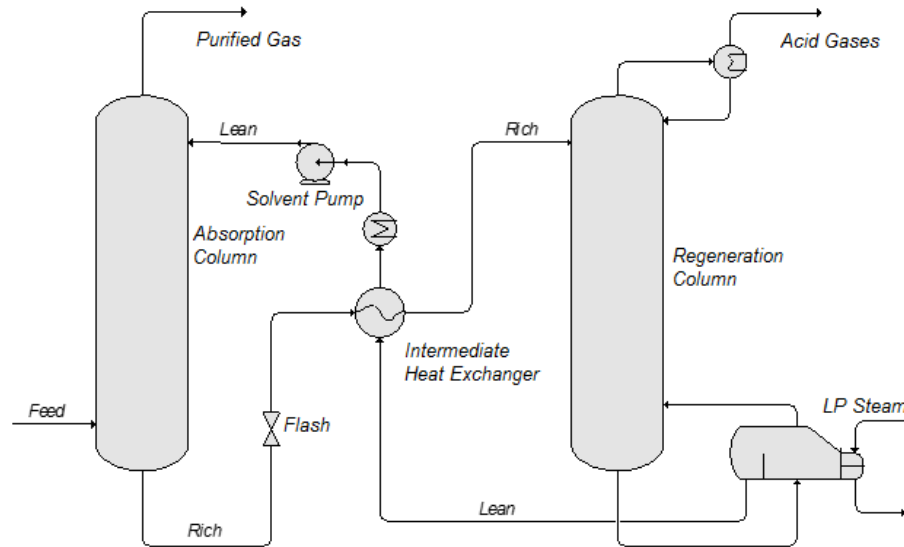

Figure 2. PFD of the MDEA absorption unit for the purification of natural gas.

The hot lean stream is cooled in the intermediate heat exchanger, furthermore cooled in a second heat exchanger and recycled to the process after make up. Make up of water and amine is needed due to leakages during solvent regeneration.

Heat to the kettle-type reboiler of the regeneration column is supplied using low pressure steam (3.5 bar²⁷).

5. Description of the case studies for the MDEA purification unit

As for the low-temperature distillation process, the gas feed to the MDEA unit is 5000 kmol/h at 50 bar, with CO₂ contents from 5 to 65 mol% and H₂S from 0 to 15 mol%. The absorption column works at 50 bar, while the regeneration column at 2 bar. The intermediate heat

exchangers operate with a minimum temperature approach of 5 °C. Useful heat is recovered inside the process.

To reduce the make up, regenerator's condenser can be operated at the lowest possible temperature compatible with the available utilities (typically from 30 to 50 °C, in this work 30 °C has been assumed).

Generally column internals can be packing or trays. In this work, on the basis of an existing amine unit²⁷, valve trays have been adopted²⁷, the internal diameter is 2.8 m and it has been chosen by a scale-down of the section of the considered amine unit²⁷.

Typically MDEA can be used in concentrations up to 60 wt%²⁸ due to its lower volatility respect to other amines. In this work 40 wt% has been assumed²⁷.

The rich loading has been selected to be 0.45 (moles of acid gas per moles of MDEA)²⁷. The limiting value of the rich loading is assumed considering the life time of the plant. The rich solution is highly corrosive due to the presence of dissociated acidic electrolytes in the aqueous phase and, generally, a reasonable value is fixed basing on experience related to existing purification units. Typically for MDEA units the rich stream loading can be as higher as 0.5 mol/mol¹⁸.

The lean solvent is regenerated to obtain an acid loading equal to 0.0045 (1/100 of the rich loading)²⁷. The temperature of the lean solvent entering the absorption unit must be 10 K higher than the one of the feed gas to favor chemical reaction kinetics; for instance if gas stream is fed at 30 °C, the lean solution temperature is 40 °C. The regeneration section has 10 theoretical trays of 4 m diameter²⁷, while the number of trays in the absorption column is varied to meet the same product specifications adopted for the low-temperature process.

To better perform the economic analysis, three different methodologies typically used by industries have been applied to determine steam consumptions in the MDEA unit. The first approach is a rule of thumb that considers a constant steam ratio respect to the volumetric flow rate of the lean solvent. In this case 0.14 kg of steam per L of lean circulating solution has been adopted, basing on the industry experience²⁷. The circulating solvent can be obtained by means of material balances knowing the product specifications and inlet gas flow rates. Generally, the steam ratio can be varied up to 0.18 kg/L, while usually a value of 0.12 kg/L is assumed²⁹. The second approach is the process simulation by means of Aspen Hysys[®] v7.3, using the DBR-Amine package developed by Schlumberger for amine purification units³⁰. The third approach is the detailed Rate-based model available in Aspen Plus[®] v7.3³¹⁻³² that uses a γ/ϕ approach for the thermodynamic framework coupled with the rigorous modeling of chemical reactions kinetics in the liquid phase and of heat and mass transfer to simulate columns with real trays. The Electrolyte-NRTL model³³⁻³⁶ is used to define the activity coefficient of the liquid phase, while the SRK³⁷ cubic EoS has been adopted to represent the vapor phase fugacity. Properly regressed binary interaction parameters for the Electrolyte-NRTL model have been adopted in order to represent the VLE of CO₂-H₂O-MDEA and H₂S-H₂O-MDEA systems. A dedicated in-house Fortran[®] subroutine has been used to simulate chemical reactions kinetics in the liquid phase coupled with rigorous mass transfer in absorption columns. The subroutine and thermodynamic model parameters have been described in previous works³⁸⁻⁴⁰ and have been applied for the rigorous simulation of industrial MDEA absorption units, such as the ones of the Gasco Habshan⁵⁴¹ natural gas purification plant near Abu Dhabi (UAE). The regeneration column has been simulated using the classical formulation of the Rate-Based model available in Aspen Plus[®].

6. Validation of the thermodynamic framework

The low-temperature distillation process has been simulated by means of the commercial process simulator Aspen Hysys[®] v7.3, using the SRK³⁷ cubic equation of state. The thermodynamic framework has been validated for the calculation of VLE, SLE and SLVE against available literature experimental data. For phase equilibria involving a solid phase, the CO₂ Freeze-Out utility available in Aspen Hysys[®] has been used and its reliability has been furthermore tested, comparing the obtained results with experimental data and the results obtained with an in-house Fortran[®] routine for the SLV equilibrium calculation, developed in previous works⁴²⁻⁴³. This routine is based on a classic approach for the calculation of solid-fluid phase equilibria. The fluid phase fugacity coefficients are calculated with a cubic EoS (SRK³⁷ and PR⁴⁴), while the one of the solid phase is calculated starting from the Gibbs free energy of melting. The routine calculates the triple point conditions at a given temperature (for the binary system) or at a given temperature and liquid phase content of H₂S (for the ternary system) coupling the solution of the VLE equations with the SLE condition, considering only one freezable compound (carbon dioxide) and a pure solid phase.

The first validation has been made considering available data for the SLV locus of the binary CH₄-CO₂ system⁴⁵⁻⁵⁷ (Fig. 3).

a)

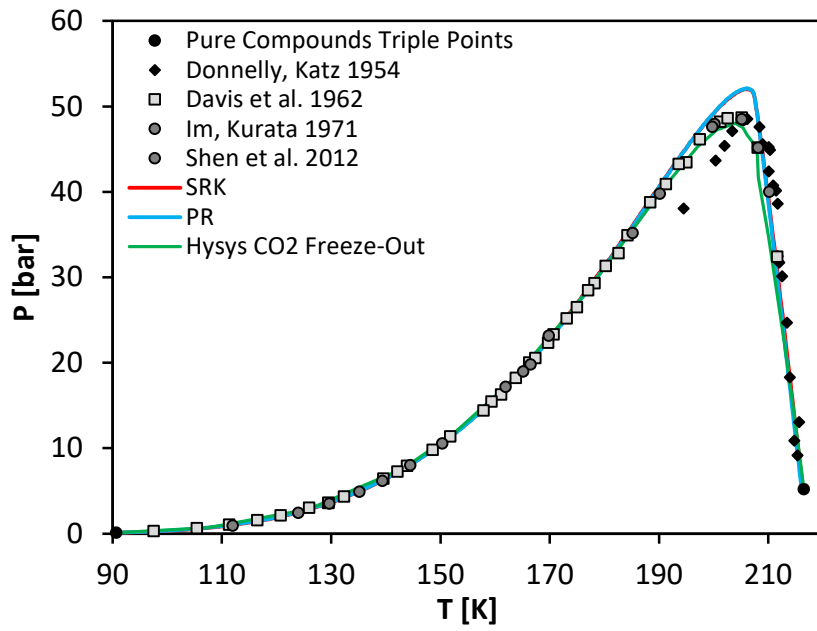

b)

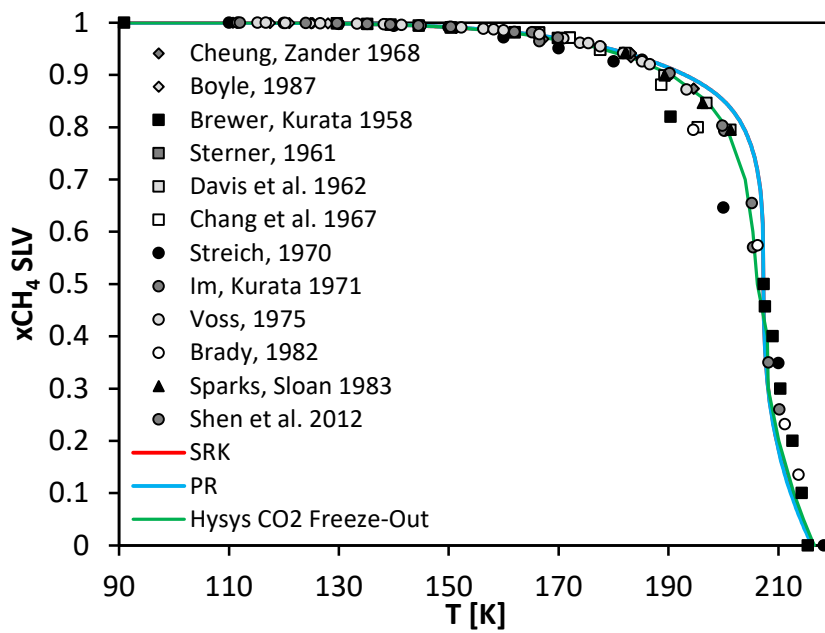

c)

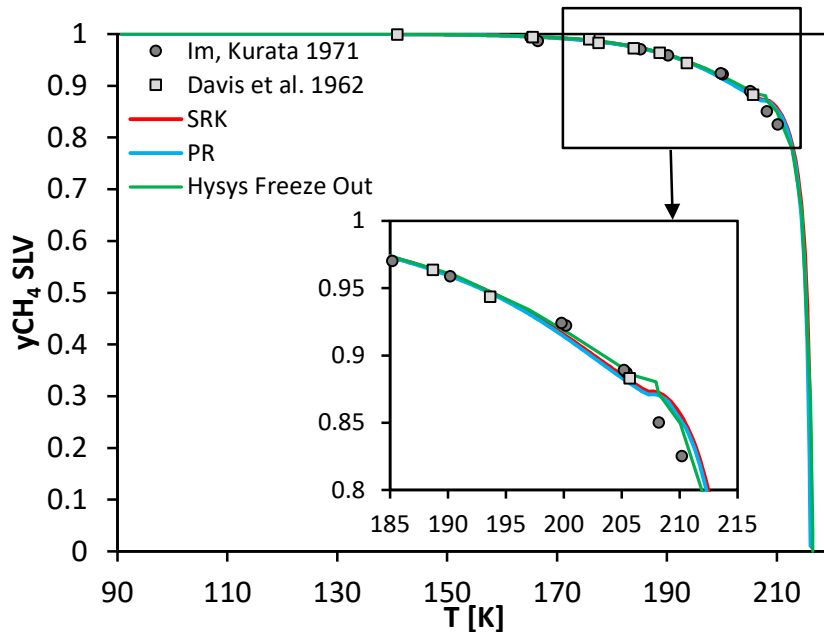

Figure 3. Comparison among results obtained with the Hysys CO₂ Freeze-Out utility, results obtained using a classical approach⁴²⁻⁴³ and experimental data⁴⁵⁻⁵⁷ for the TPxy SLV locus for the binary CH₄-CO₂ system: a) PT diagram, b) Tx solubility diagram and c) Ty diagram.

The agreement between the results obtained with the calculation methods and experimental data is good. The curves obtained using the Hysys CO₂ Freeze-Out utility are close to experimental data in the Tx diagram (Fig. 3b) for temperatures between 190 and 210 K, while the results obtained using the classic approach are slightly above experimental points. For the PT diagram of the SLV locus for the binary CH₄-CO₂ system (Fig. 3a), all the methods have difficulties to reproduce correctly the behavior in the proximity of the maximum. Classic approaches tend to overestimate the maximum pressure of the SLV locus, as observed also in other literature works⁵⁸ where these methods are used, while the process simulator utility tends to slightly underestimate this value.

The reliability of the thermodynamic framework (SRK EoS) of the process simulator has been validated also considering VLE data⁵⁹ for the binary CH₄-CO₂ system (Fig. 4).

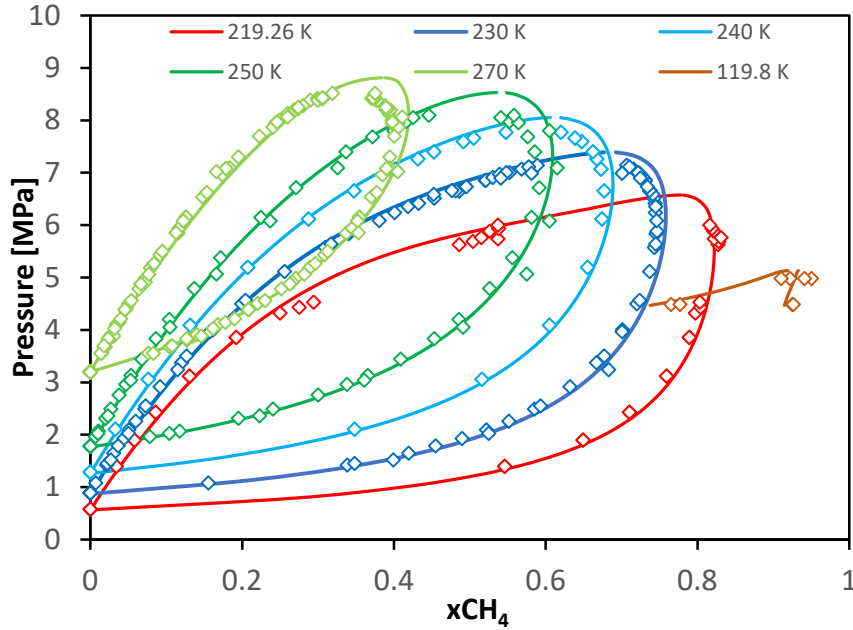
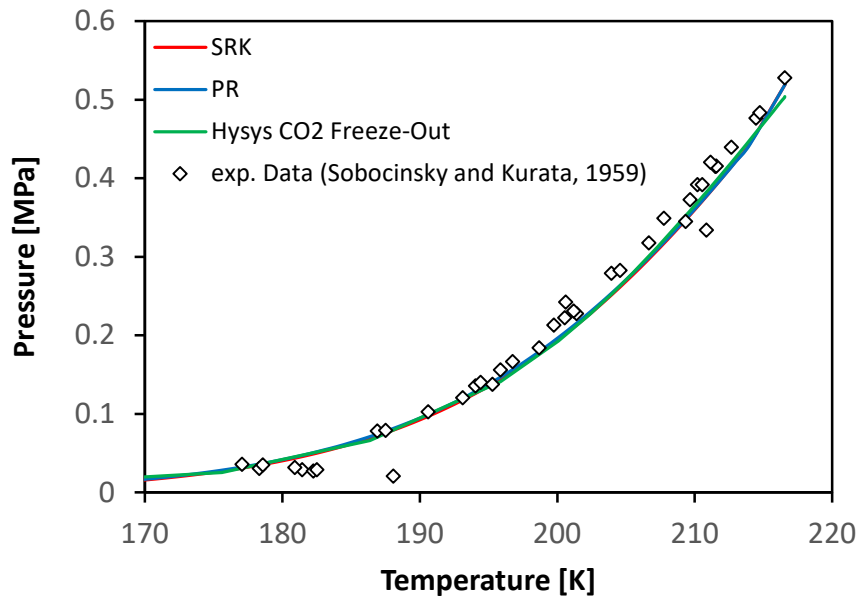

Figure 4. Comparison between results obtained with the Hysys SRK EoS and experimental data⁵⁹ for the VLE of the binary CH₄-CO₂ system.

The agreement between model results and experimental data⁵⁹ is good. The model tends to overestimate bubble and dew pressures in the proximity of the critical points of the mixture.

The assessment of the reliability of the thermodynamic framework used for process simulations has been performed also considering the SLV locus for the binary CO₂-H₂S system (Fig. 5). Experimental data have been taken from literature⁶⁰, showing the presence of a eutectic point in the SLV locus of the considered system. The CO₂ Freeze-Out tool available in Aspen Hysys[®] can account only a pure CO₂ solid phase and so, without considering the solidification of H₂S, the eutectic point cannot be detected.

a)



b)

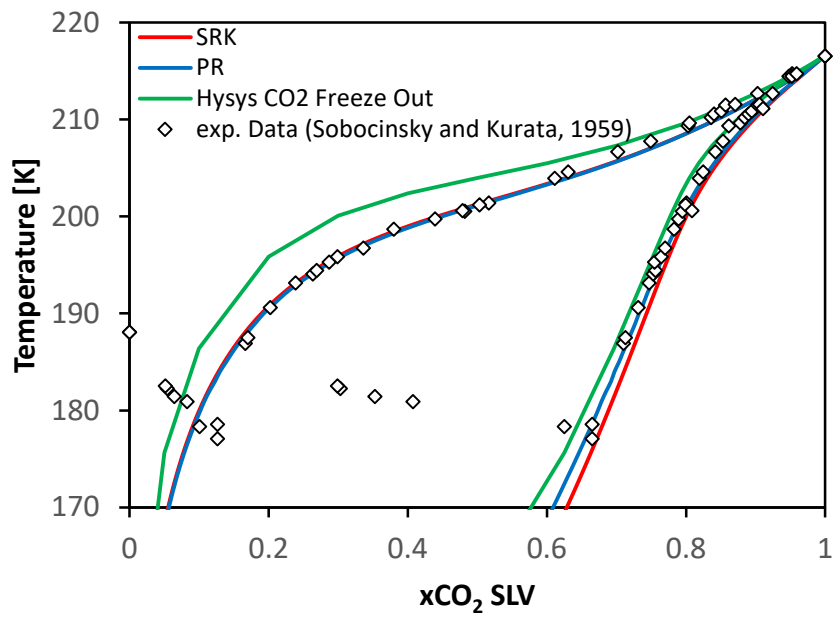

c)

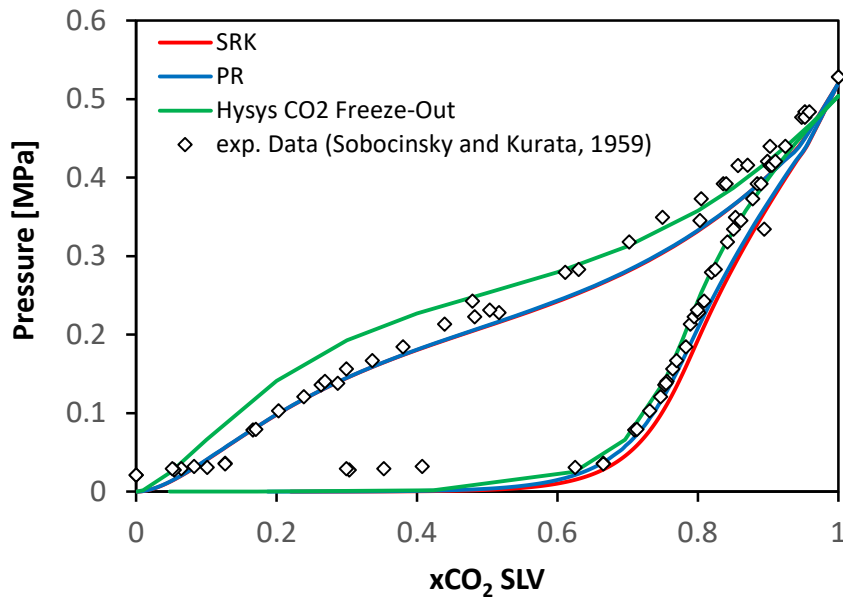
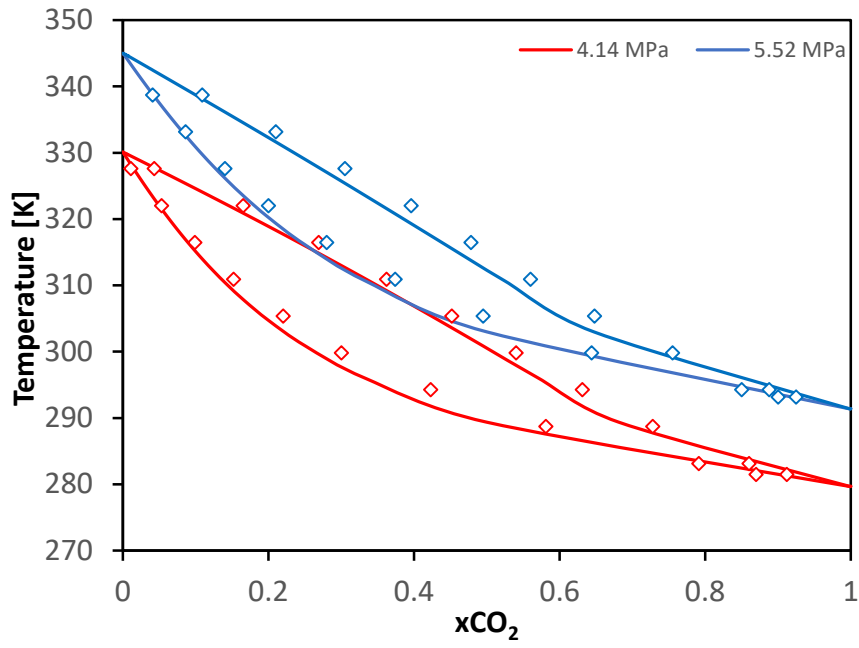

Figure 5. Comparison among results obtained with the Hysys CO₂ Freeze-Out utility, the results obtained using a classical approach⁴²⁻⁴³ and experimental data⁶⁰ for the TP_{xy} SLV locus for the binary CO₂-H₂S system: a) PT diagram, b) T_{xy} diagram and c) P_{xy} diagram.

The SLV branch from the eutectic point to the pure CO₂ triple point is well reproduced by all the three thermodynamic models. The branch that ends at the pure H₂S triple point is not calculated, since only CO₂ has been assumed to be the freezable compound. Bigger discrepancies are present both in the T_{xy} and P_{xy} diagrams between experimental data and the results obtained with the CO₂ Freeze-Out utility.

The VLE representation has been checked for both the CO₂-H₂S and CH₄-H₂S systems, by comparison between the model results obtained with the Hysys SRK EoS and literature-available experimental data⁵⁹ (Fig. 6).

a)



b)

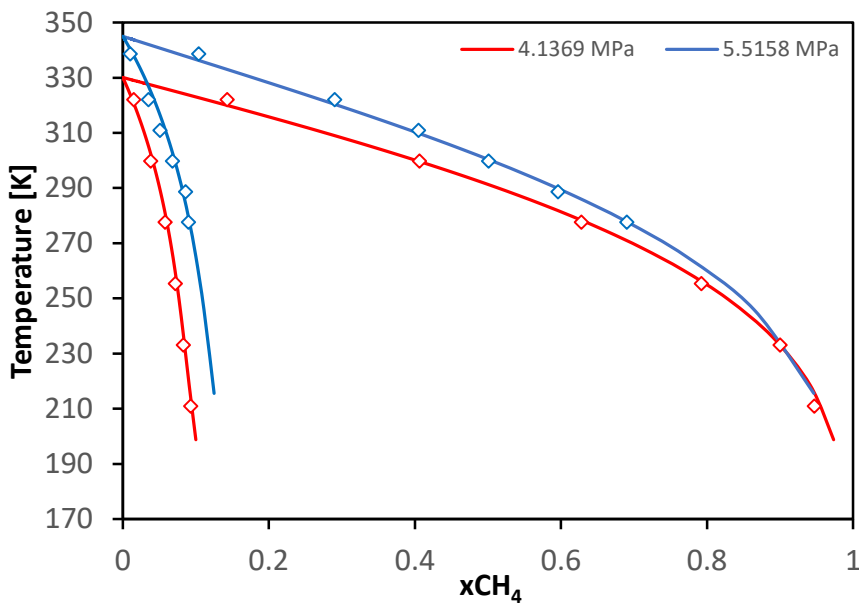

Figure 6. Comparison between results obtained with the Hysys SRK EoS and experimental data⁵⁹ for the VLE of a) the binary CO₂-H₂S and b) the binary CH₄-H₂S systems.

The agreement between model calculations and experimental data⁵⁹ is good. The thermodynamic framework has been considered reliable for the representation of phase equilibria of interest for the low-temperature distillation process.

The thermodynamic framework for the simulation of the MDEA units have been already tested in previous works³⁸⁻⁴⁰, as well as the one for the simulation of the dual-pressure process when also H₂S is present⁶¹.

7. Definition of the merit index function

To establish the profitability of the studied process solution, the comparison with more classical gas purification units, such as the chemical absorption with aqueous MDEA solutions, has been carried out in terms of operating costs related to the energy consumptions of the two processes.

The low temperature distillation process requires electric energy to drive the compressors of the refrigeration cycle adopted to provide the cooling duty. The chemical absorption unit consumes low-pressure steam to provide heat for the solvent regenerator reboiler. Heat is required to break chemical bonds established between the solvent and the acidic compounds removed from the natural gas streams in addition to the latent heat of vaporization required to create a vapor phase that strips CO₂ and H₂S from the rich solution coming from the absorption column.

Once determined the energy requirements of the low-temperature distillation process and the ones of the MDEA unit, it is possible to establish the trade-off between the two technologies considering the ratio between the operating costs related to energy demands:

$$CE_{MDEA} = \dot{Q}_{Reboiler} \$_{Steam} \quad (1)$$

$$CE_{LT} = \frac{\dot{Q}_{Cool}}{COP_f} \$_{Elec} = W_{LT} \$_{Elec} \quad (2)$$

where CE are the costs of energy for the MDEA unit and the low-temperature (LT) distillation process, \dot{Q} is the duty, \dot{W} is the compression work, $\$_{Steam}$ is the cost of LP steam and $\$_{Elec}$ is the cost of electricity.

The ratio between Eq. (1) and (2) represents the merit index function (Eq. (3)). Considering a natural gas stream having a certain content of acid gases, if this ratio is equal to one, from the energy expenses point of view, the two processes are equivalent (breakeven point); while, if the ratio is greater than one, the amine process requires a bigger energy cost respect to the low-temperature distillation process.

$$\frac{CE_{MDEA}}{CE_{LT}} = \frac{\dot{Q}_{Reboiler}}{\dot{W}_{LT}} \cdot \frac{\$_{Steam}}{\$_{Elec}} \quad (3)$$

It is possible to notice that, knowing the energy consumptions of the two processes, once defined the COP of the refrigeration cycle (COP_f), the trade-off is defined by the ratio between the costs of steam and electricity. This ratio is a function of the geographic area where the natural gas resource is available.

The results obtained from calculations and process simulations for the power requirements by the two processes can be used to express the $\frac{\dot{Q}_{Reboiler}}{\dot{W}_{LT}}$ ratio, using simple mathematical functions. By plotting this ratio at different H₂S and CO₂ compositions in the raw gas feed, it is possible to define second order correlations; these equations describe in an accurate way the relationship between the ratios of energy requirements as function of the CO₂ content of raw natural gas, for different hydrogen sulfide concentrations. This procedure can be repeated for each of the three methodologies used to determine the reboiler duty of MDEA units.

The function used is:

$$\frac{\dot{Q}_{Reboiler}}{\dot{W}_{LT}} = f(x_{CO_2}, x_{H_2S}) = a(x_{H_2S})x_{CO_2}^2 + b(x_{H_2S})x_{CO_2} + c(x_{H_2S}) \quad (4)$$

where a, b, c are the correlation coefficients, function of the hydrogen sulfide mol% in the natural gas (x_{H_2S}), and x_{CO_2} is the mol% of carbon dioxide in the natural gas.

The definition of the ratio between energy prices is needed to build curves that can give in an easy way the trade-off between these two technologies basing on the geographic area, natural gas composition and a parameter that expresses the ratio between the cost of steam and the cost of electricity. Since the effective price of energy depends on many factors and regulations, it is better to use the ratio as a parameter, to generalize the use of this correlation.

The breakeven point occurs when:

$$\frac{CE_{MDEA}}{CE_{LT}} = \frac{\dot{Q}_{Reboiler}}{\dot{W}_{LT}} \cdot \frac{\$_{Steam}}{\$_{Elec}} = 1 \quad (5)$$

Starting from this, knowing that $\frac{\dot{Q}_{Reboiler}}{\dot{W}_{LT}}$ can be expressed with correlations (Eq. (4)), it is possible to obtain:

$$\frac{\$_{Steam}}{\$_{Elec}} = \frac{1}{f(x_{CO_2}, x_{H_2S})} \quad (6)$$

and define curves based on the ratio between the price of steam and the price of electricity.

The price of steam, however, may not be suitable for direct application in economic considerations, but it can be related to the price of gas, which is the most important expense in steam production. Moreover, for economic analysis aimed to compare different possible process solutions, the price of natural gas per country can be outsourced from literature, while it is more difficult to find directly the price of steam.

The relation between the price of steam and the price of fuel gas (considered as methane, LHV 50 MJ/kg⁶²) can be derived considering a classic industrial boiler. From industry information²⁷, the boiler produces 140 MW of thermal power (LP steam at 3.5 bar) using 800 kWe to drive pumps and needs, as boiler feed water (BFW) make-up, the 2% in weight of the total circulating

steam. The efficiency of the industrial boiler (η_{boiler}) is 0.8⁶³. BFW cost is assumed equal to 0.0015 \$/kg⁶⁴. The cost of steam can be related, in this way, (Eqs. (7)-(10)) to the OPEX of the boiler and to its thermal energy productivity. OPEX are: electric energy requirements, BFW and fuel gas.

$$\$_{STEAM} \left[\frac{\$}{kWh} \right] = \frac{C_{FUEL} + C_{BFW} + C_{ELEC}}{Boiler\ Capacity\ [kW] \cdot 1[h]} \quad (7)$$

$$C_{FUEL} \left[\frac{\$}{h} \right] = \$_{FUEL} \left[\frac{\$}{kg} \right] \frac{Boiler\ Capacity\ [MW]}{LHV_{FUEL} \left[\frac{MJ}{kg} \right] \eta_{BOILER}} \cdot 3600 \left[\frac{MJ}{MWh} \right] \quad (8)$$

$$C_{BFW} \left[\frac{\$}{h} \right] = \$_{BFW} \left[\frac{\$}{kg} \right] \frac{Boiler\ Capacity\ [MW] \cdot 3600 \left[\frac{MJ}{MWh} \right]}{\Delta H_{ev,water} (= 2148 \frac{kJ}{kg} @ 3.5\ [bar]) \cdot 0.001 \left[\frac{MJ}{kJ} \right]} \cdot 0.02 \quad (9)$$

$$C_{ELEC} \left[\frac{\$}{h} \right] = \$_{ELEC} \left[\frac{\$}{kWh} \right] \dot{W}_{pump} (= 800[kW])$$

(10)

where C are the costs and $\$$ the prices of the different utilities. Introducing each term (Eqs. (8)-(10)) in Eq. (7) and dividing each side by the price of electricity, it is possible to obtain:

$$\frac{\$_{Steam} \left[\frac{\$}{kWh} \right]}{\$_{Elec} \left[\frac{\$}{kWh} \right]} = \frac{1}{\eta_{boiler}} \frac{\$_{Fuel} \left[\frac{\$}{kWh} \right]}{\$_{Elec} \left[\frac{\$}{kWh} \right]} + \frac{\$_{BFW} \left[\frac{\$}{kWh} \right]}{\$_{Elec} \left[\frac{\$}{kWh} \right]} + \frac{\dot{W}_{pump} [kW]}{\dot{Q}_{boiler} [kW]} \quad (11)$$

Introducing the value of each variable, the relation becomes:

$$\frac{\$_{Steam}}{\$_{Elec}} = 1.25 \frac{\$_{Fuel}}{\$_{Elec}} + \frac{0.00005}{\$_{Elec}} + 0.005714 \quad (12)$$

The term $\frac{0.00005}{\$_{Elec}}$ is negligible, compared with the other terms: the costs related to BFW are the lowest in comparison with the ones of fuel and electricity. In this way, it is possible to obtain the relation between the price of steam and the price of fuel to relate the breakeven point function to the prices of gas and electricity:

$$\frac{\$_{Steam}}{\$_{Elec}} = 1.25 \frac{\$_{Fuel}}{\$_{Elec}} + 0.005714 \quad (13)$$

The expression is linear and in good agreement with the one reported by the US DOE⁶⁵, which consider the function as a line with a slope of 1.3 and zero intercept. However, the derivation of Eq. (13) is more rigorous, since the intercept is non-zero to take into account electric energy expenses during steam generation. To better assess the validity of the relation and the effect of neglecting the contribution of the cost of BFW, the price of steam has been calculated using the complete expression (Eq. (11)). Prices of natural gas and electricity, by region, reported in literature⁶⁶⁻⁶⁸ have been used and the calculated values have been correlated using a linear function (Fig. 7).

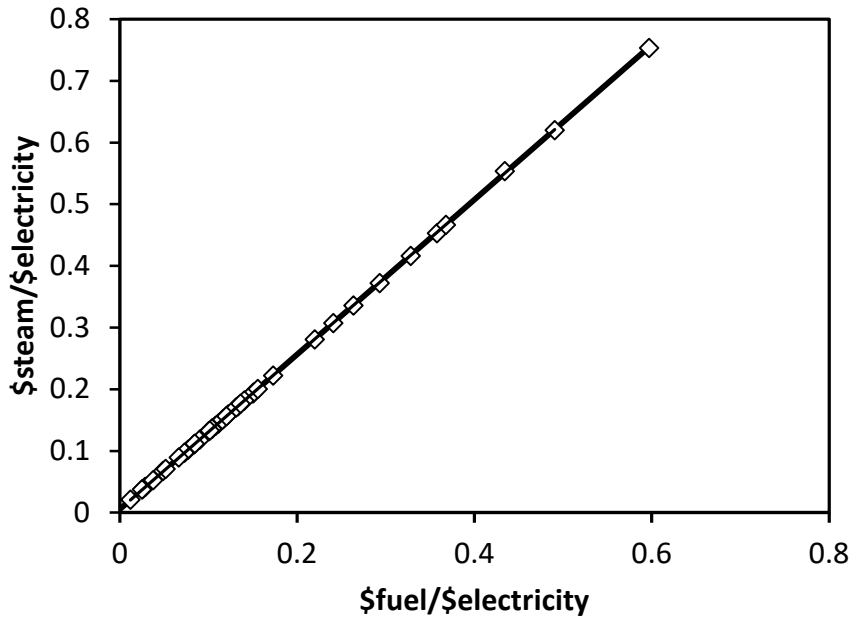

Figure 7. Trend (line) of the values of the price of steam (points) as function of the price of gas (Eq. (11)), calculated using available costs in literature for electricity and natural gas.

The obtained trend is:

$$\frac{\$Steam}{\$Elec} = 1.2549 \frac{\$Fuel}{\$Elec} + 0.0056 \tag{14}$$

The coefficients of Eq. (14) are close to the ones obtained theoretically in Eq. (13) and the methodology adopted is consistent: the BFW contribution does not affect model coefficients in a significant way. It is possible to use Eq. (14) in terms of $\frac{\$Fuel}{\$Elec}$:

$$\frac{\$Fuel}{\$Elec} = \frac{1}{1.2549} \left(\frac{\$Steam}{\$Elec} - 0.0056 \right) \quad (15)$$

Introducing Eq. (15), the breakeven point of Eq. (16) can be defined in terms of $\frac{\$Fuel}{\$Elec}$ instead of using the cost of steam:

$$\frac{\$Fuel}{\$Elec} \Big|_{BEP} = \frac{1}{1.2549} \left(\frac{1}{f(x_{CO_2}, x_{H_2S})} - 0.0056 \right) \quad (16)$$

This provides a more direct result, because, typically, prices of gas and electricity are available per each country.

It is possible in this way to build curves that describe the variation of the breakeven point between the low-temperature distillation process and the traditional MDEA unit, as functions of the contents of acidic compounds in the natural gas and the prices of gas and electricity.

8. Results and discussion

8.1 The rationale of the process

The rationale of the process to avoid the solid CO₂ formation is the bypass of the maximum of the SLV locus of the methane-carbon dioxide system. On the basis of the thermodynamic study, it is possible to define the process in terms of PT and phase diagrams (Figs. 8-9) in order to better understand the behavior of the proposed solution.

In the HP section the separation is limited by the critical point of the mixture, that doesn't allow to reach the commercial grade for the methane stream. So the mixture must be depressurized slightly under the critical pressure of pure methane, avoiding huge recompression

costs. At 50 bar the SLE and the VLE surfaces are completely divided, thus no solidification during distillation operation may occur, since distillation is a unit operation that involves the presence of a vapor and liquid phase contemporarily. Solidification inside distillation units can occur only at the triple point. During the cooling at 50 bar of the split part of stream 314 (HP section top product) the SLE is never crossed, so the operation is performed without freezing. Once expanded at 40 bar, stream 320 arrives at 40 bar without crossing the SLV locus during the expansion. The part of stream 314 that goes to the intermediate heater (stream 316) cannot be fed to the LP section without superheating, otherwise the produced stream at 40 bar can form a solid phase in the solid-vapor region at 40 bar.

To avoid the frosting of carbon dioxide at the inlet of the LP section, the stream must be heated at 50 bar before expansion. The limiting condition to frosting is the dew point of stream 319 at 40 bar. For safety reasons, it is suggested to keep the temperature of this stream 5-6 °C over its dew point at 40 bar, avoiding the formation of a solid phase. In this way the presence of dry ice is avoided in all the parts of the process. From the top of the LP section, a methane stream at commercial specification is obtained, while the liquid bottom product stream 324 is pumped back to 50 bar and sent to the top of the HP section few theoretical trays over the feed tray. To avoid the freezing at the outlet of the LP section, the maximum CO₂ content of this stream must be kept at about 8 mol%, so that the LP section of the distillation unit operates in the liquid-vapor region under the low-temperature triple point at 40 bar.

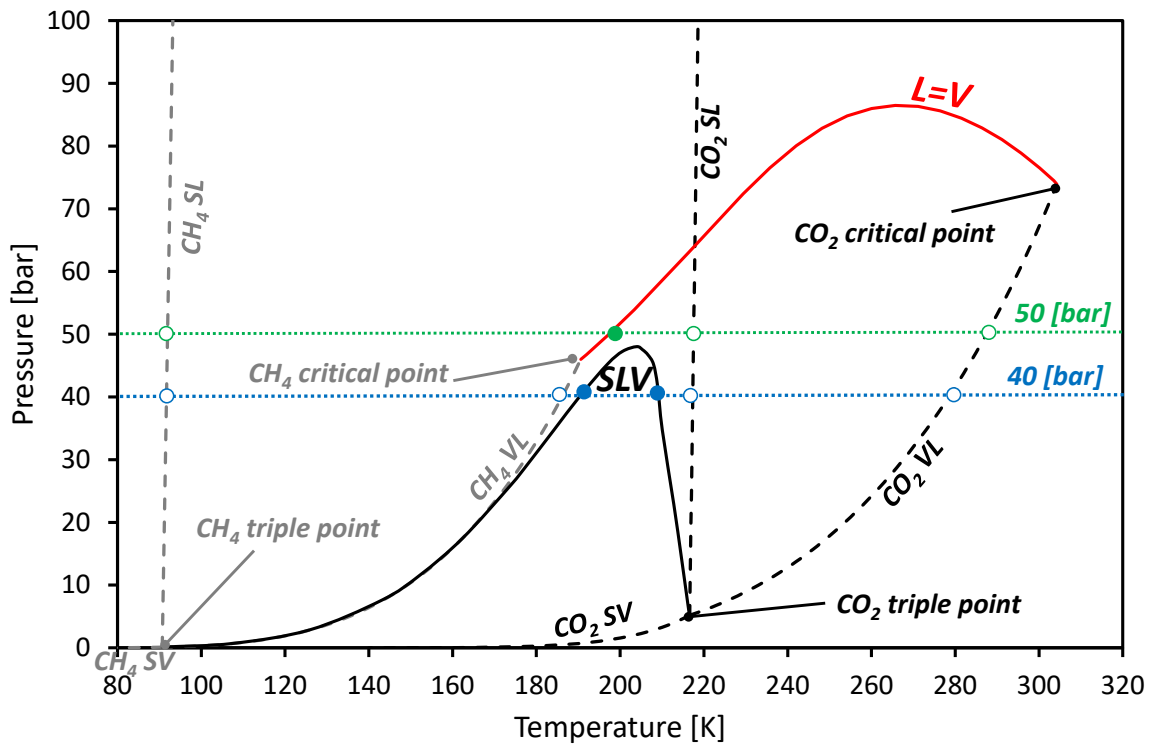
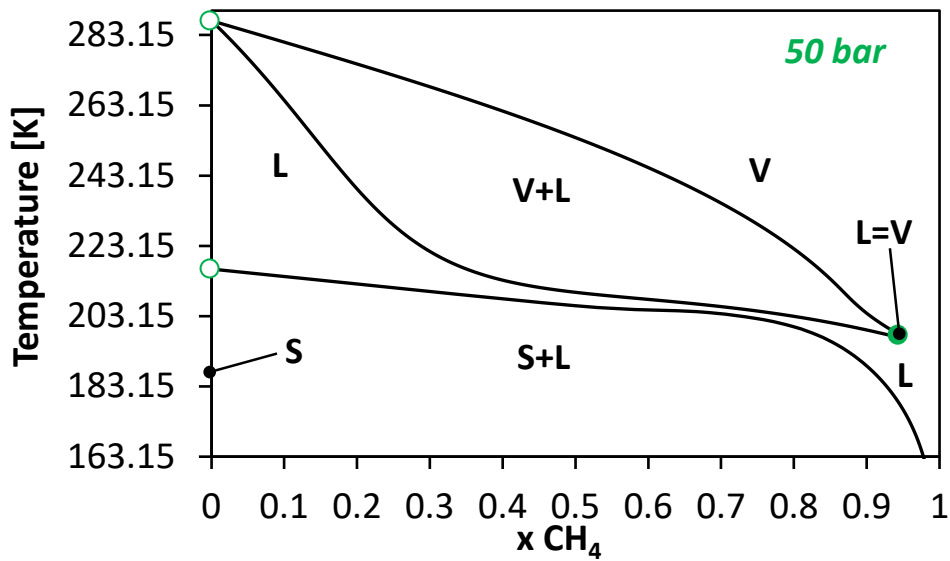

Figure 8. Thermodynamic representation of the process in terms of PT diagram.

a)



b)

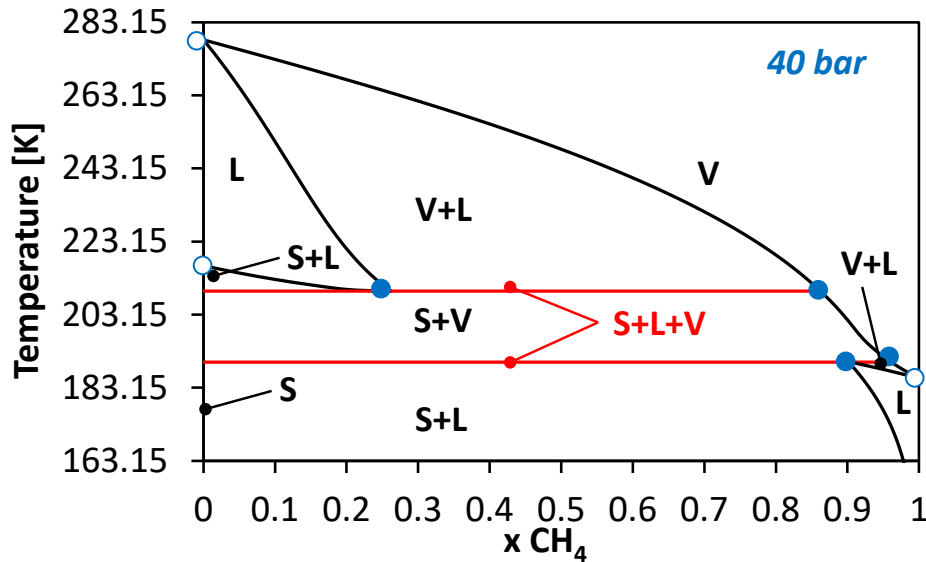

Figure 9. Thermodynamic representation of the process in terms of isobaric phase diagrams at a) 50 bar and b) 40 bar.

8.2 The energy consumptions of the low-temperature distillation process

In order to perform the economic evaluation to define the trade-off between the proposed solution and classical MDEA units, it is necessary to define the energy consumptions related to the new purification process.

The introduction of the feed-splitting technique allows to obtain significant energy savings, reducing the overall cooling duty in comparison with the base configuration of the process (Fig. 10). Results in terms of cooling duties required by the two low-temperature process configurations (Fig. 1) have been obtained from process simulations, verifying that the process is able to purify the gas feed to commercial grade.

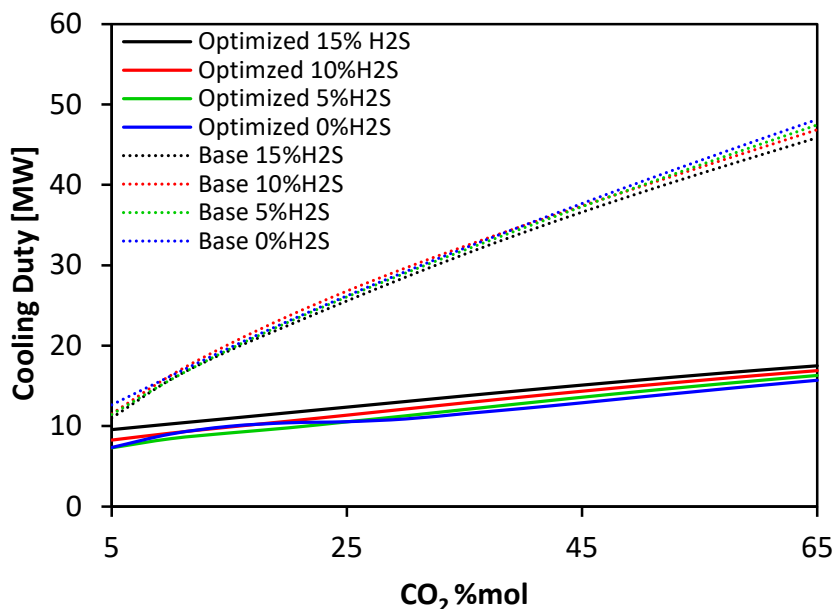

Figure 10. Comparison between the cooling duties required by the low-temperature distillation process for the optimized configuration with the feed-splitting technique and the base layout.

The optimized process layout seems to be the most attractive for an industrial application, since it allows an effective energy saving up to 65% in comparison with the base layout.

For this reason, the optimized process solution has been used to establish the trade-off of the proposed low-temperature distillation process respect to the more traditional MDEA scrubbing unit depending on natural gas composition. Further details about the process simulation results and the study on the performances of the low-temperature process can be found elsewhere⁶⁹.

8.3 Energy consumptions of the MDEA purification unit

The three discussed methodologies have been used to calculate the reboiler duty for the MDEA regeneration column. The duty is directly related to the steam consumptions. Results obtained are reported in Fig. 11.

a)

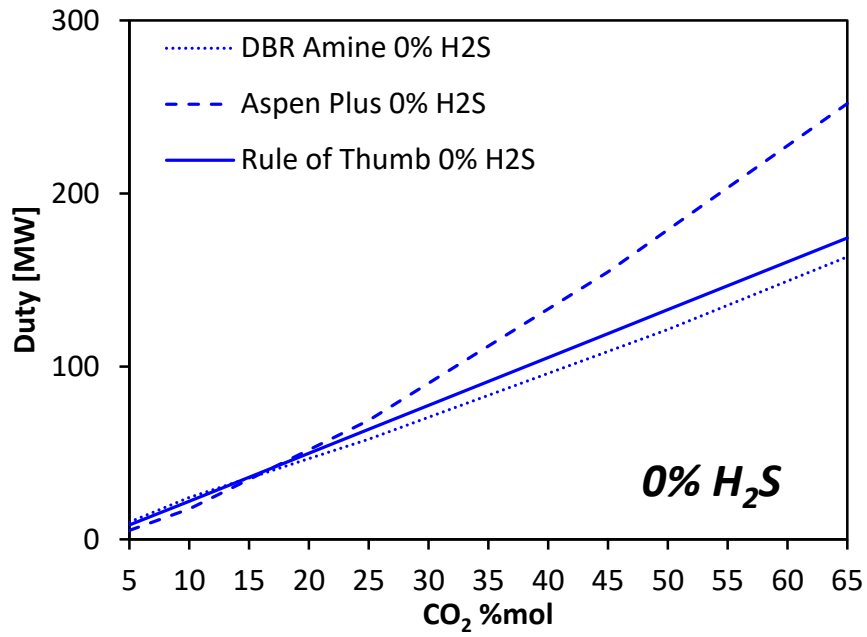

b)

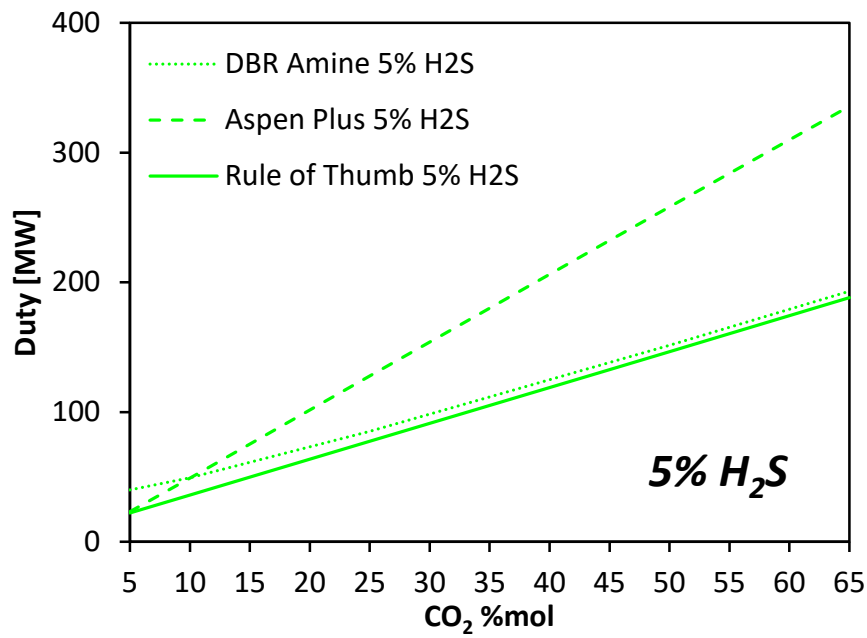

c)

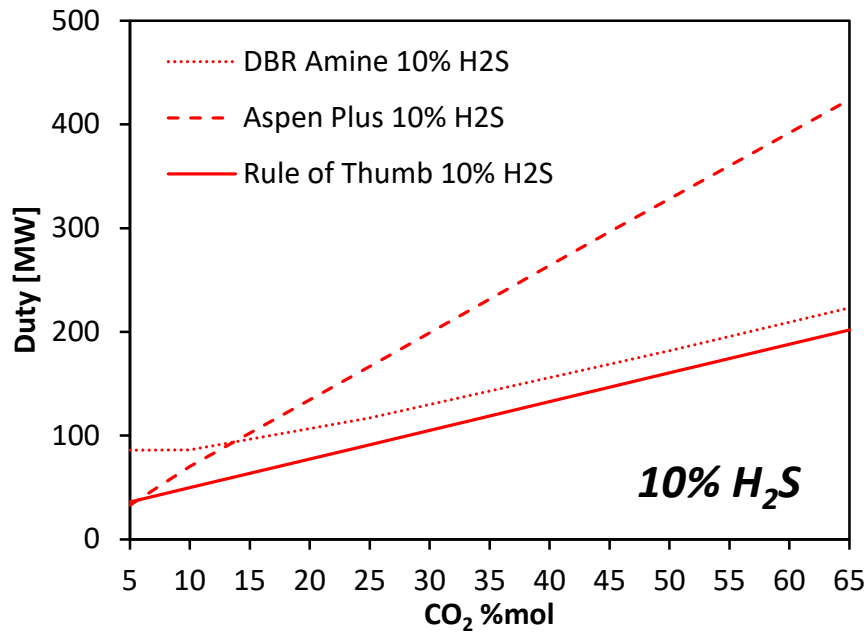

d)

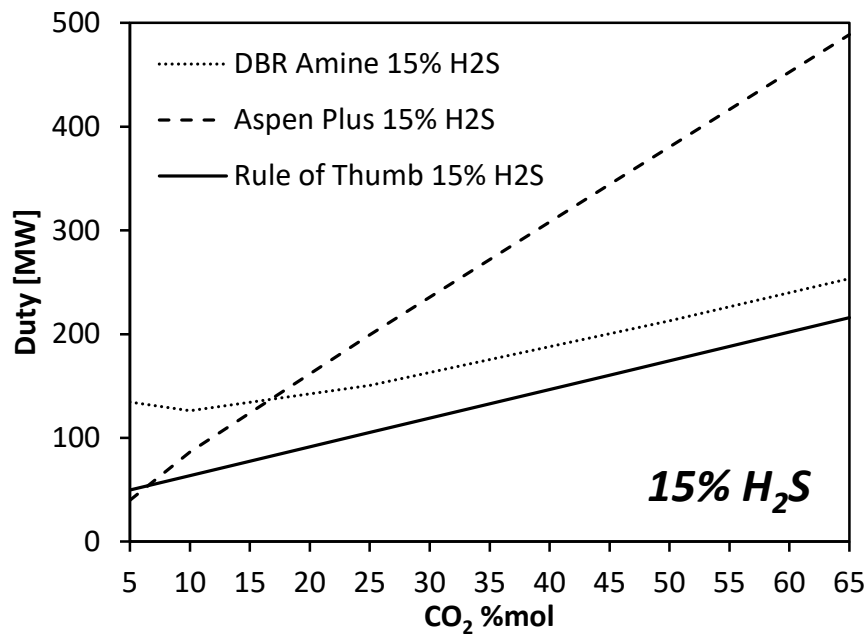

Figure 11. Estimation of the MDEA regeneration column reboiler duty with the three different adopted methodologies as function of the CO₂ content of the raw gas feed to the process and for different values of H₂S mole fraction in the gas feed: a) 0 mol%, b) 5 mol%, c) 10 mol% and d) 15 mol%.

The comparison shows quite good agreement between results obtained using the DBR-Amine package and the rule of thumb at 0 and 5 mol% of hydrogen sulfide in the raw gas feed, while differences increase at higher H₂S contents. The results obtained with the methodology used in Aspen Plus[®] are in good agreement with the ones obtained using the rule of thumb at low carbon dioxide contents (5 mol%), while differences are significant when the CO₂ and H₂S molar fractions in the raw gas feed increase.

Generally the reboiler duty, calculated with the three different methodologies, has a linear trend with the CO₂ content of the feed gas, for any amount of H₂S. Using the DBR Amine Package available in Aspen Hysys[®], it is possible to notice that the trend is linear and in good agreement with the results obtained using the rule of thumb at low H₂S contents, while for higher concentrations of hydrogen sulfide the curves show a minimum at low CO₂ content. This behavior is not physically meaningful, because the heat required for the regeneration of the solvent to meet the loading specifications monotonically increases with the amount of absorbed acidic compounds.

For the sake of economic comparisons, in terms of energy demand, between the low-temperature process object of this work and the MDEA unit, the results obtained using the rule of thumb for the estimation of MDEA regenerator reboiler duty are the lowest and therefore allow to be conservative in the comparison. If the energy expenses of the low-temperature distillation process are lower than the ones obtained using the rule of thumb method, they will be

far away much lower than the ones calculated using the other two methodologies, resulting in a much better profitability index of the low-temperature distillation process respect to the classical MDEA unit.

8.4 Comparison between the low-temperature distillation process and the MDEA purification process

To perform the economic analysis, the cooling duty of the low temperature distillation process is converted into the compression work required to drive the refrigeration cycle. The COP considered for the refrigeration cycle is 0.67 and the cycle is a cascade system where propane is used in the high-temperature loop and ethylene is used in the low-temperature loop in order to provide cold to the process at temperatures of about -100 °C. Details about the refrigeration cycle selection and the determination of the value of the COP used in this work for the economic comparison are given in detail elsewhere⁶⁹. From simulation results, the ratio between the duty required by MDEA regeneration column reboiler and the compression work required by the refrigeration cycle has been parametrized according to Eq. (4). Results are shown in Fig. 12 and coefficients for Eq. (4) are listed in Table 1.

a)

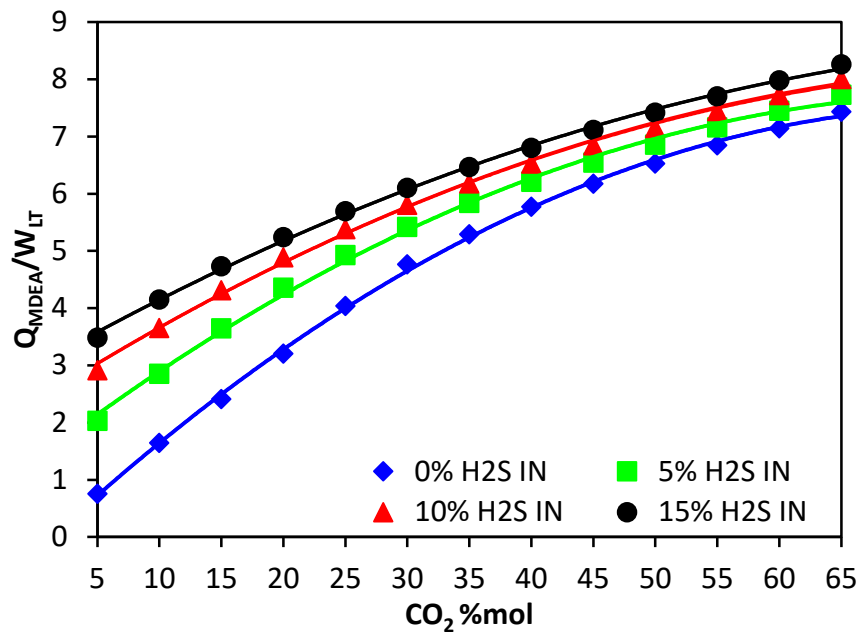

b)

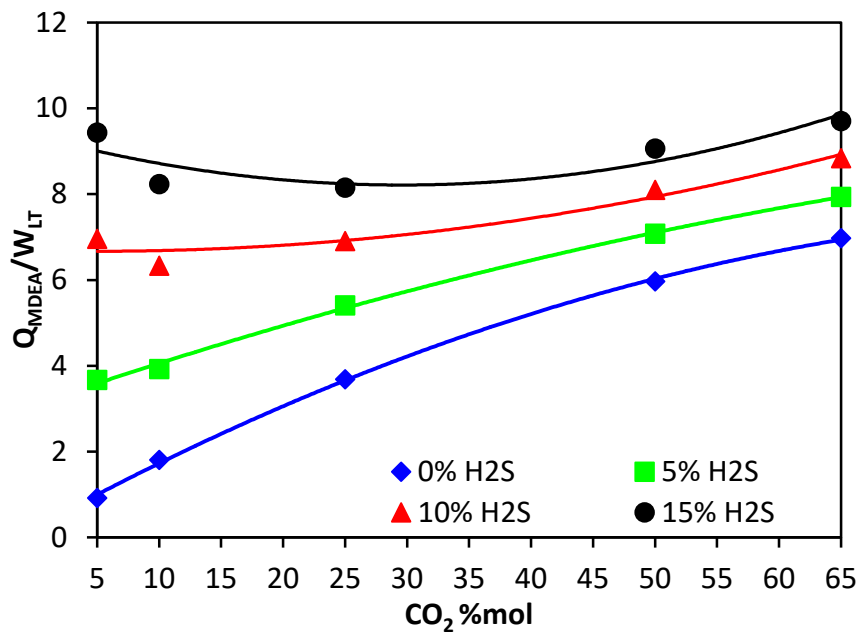

c)

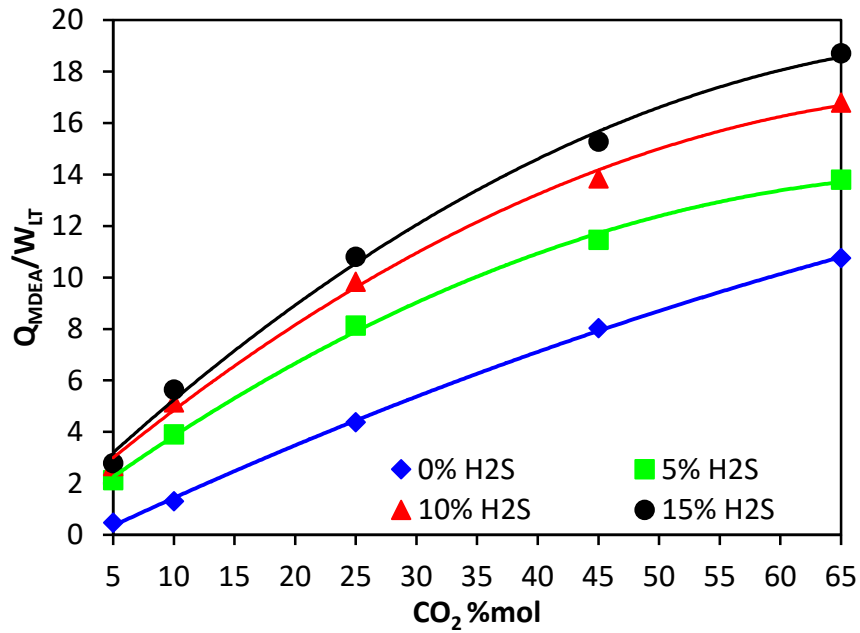

Figure 12. Results obtained for $\frac{\dot{Q}_{Reboiler}}{W_{LT}}$ using for the calculation of the MDEA unit reboiler duty a) the rule of thumb, b) the Schlumberger DBR-Amine package in Aspen Hysys® and c) the detailed model in Aspen Plus®. Dots are the calculation results from simulations and lines are the mathematic correlations used to describe the trend (Eq. (4)) with coefficients reported in Table 1.

Table 1. Coefficients for the second order correlations (Eq. (4)) that describe the trend of the parameter $\frac{Q_{Reboiler}}{W_{LT}}$ using results obtained from process simulations and their accuracy R^2 for the three methodologies used to estimate the MDEA unit reboiler duty.

Rule of Thumb				
% H₂S	a	b	c	R²
0	-0.001327457	0.203448964	-0.257910905	0.9992
5	-0.001079637	0.166525619	1.337223397	0.9976
10	-0.000807812	0.137722857	2.364158308	0.9980
15	-0.000658393	0.122715652	2.985942628	0.9987
Schlumberger DBR-Amine package in Aspen Hysys®				
% H₂S	a	b	c	R²
0	-0.000851154	0.158602418	0.225819090	0.9993
5	-0.000384963	0.099301476	3.102270351	0.9979
10	0.000627662	-0.006305425	6.685517406	0.9410
15	0.001312731	-0.077640568	9.362000743	0.7268
Detailed model in Aspen Plus®				
% H₂S	a	b	c	R²
0	-0.000762705	0.227363510	0.764062307	0.9994
5	-0.002280022	0.350446136	0.561076204	0.9985
10	-0.002572925	0.408224470	1.016398901	0.9974
15	-0.002794227	0.451755488	1.003667351	0.9967

The correlations show a good accuracy, well reproducing the results from simulations. They allow to simplify the procedure since can be used inside Eq. (16) to determine the trade-off

between the low-temperature distillation process and the traditional MDEA purification unit in terms of energy expenses. Results are shown in Fig. (13).

a)

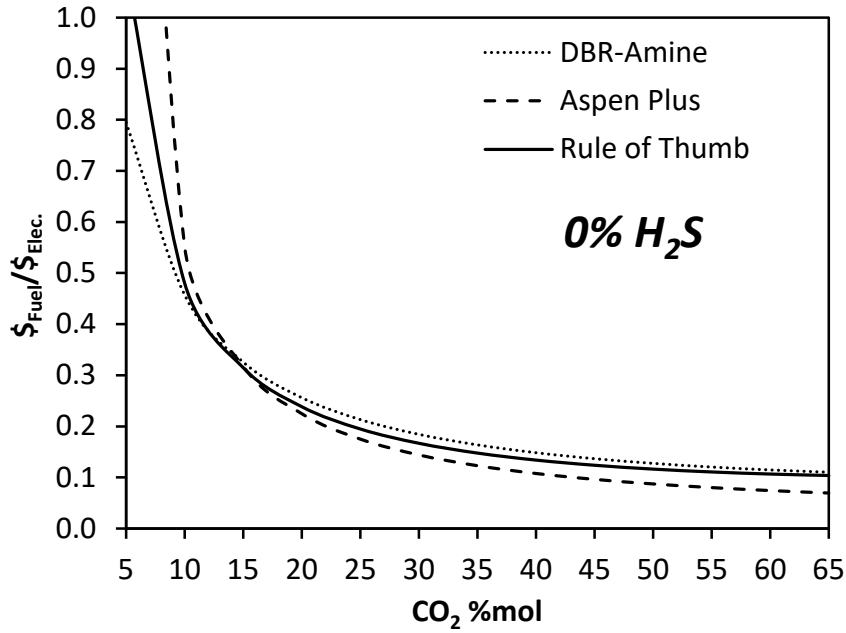

b)

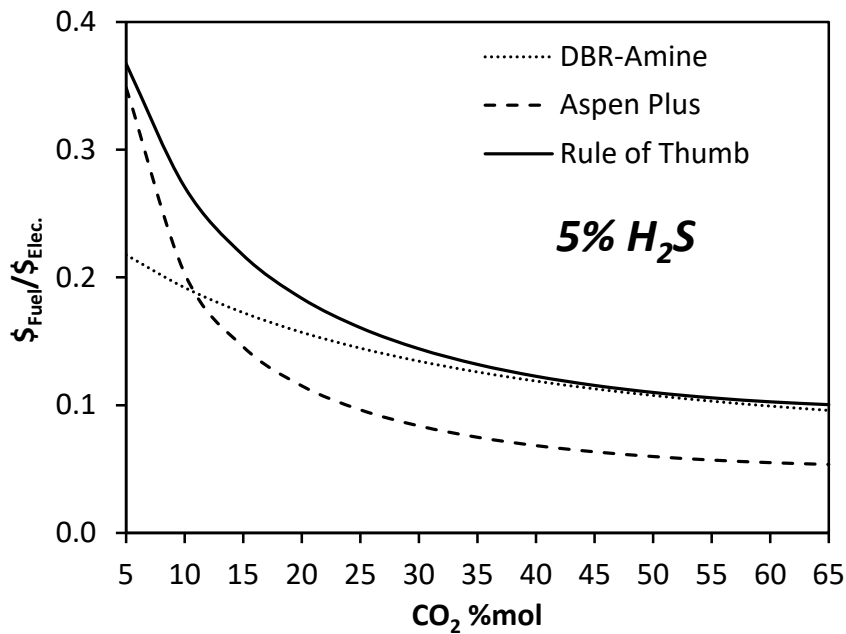

c)

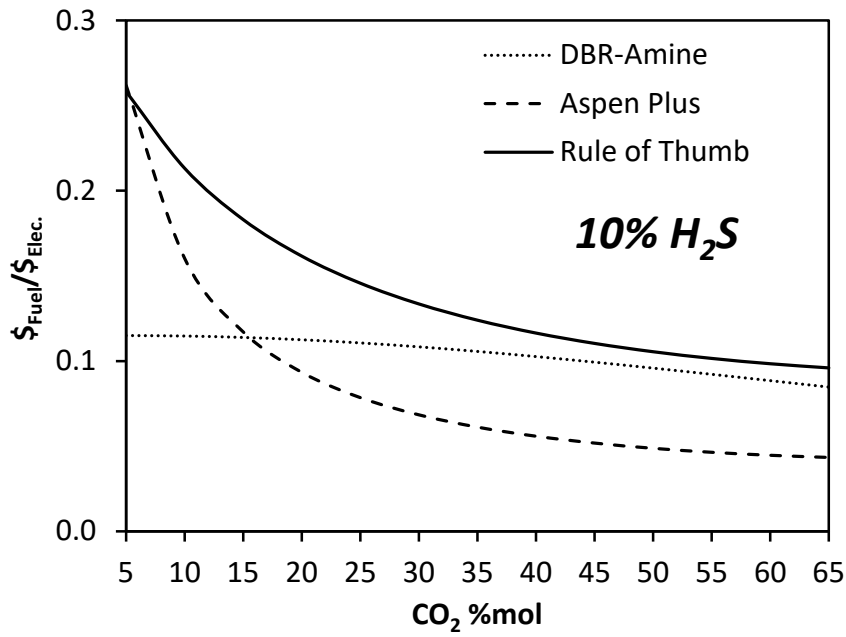

d)

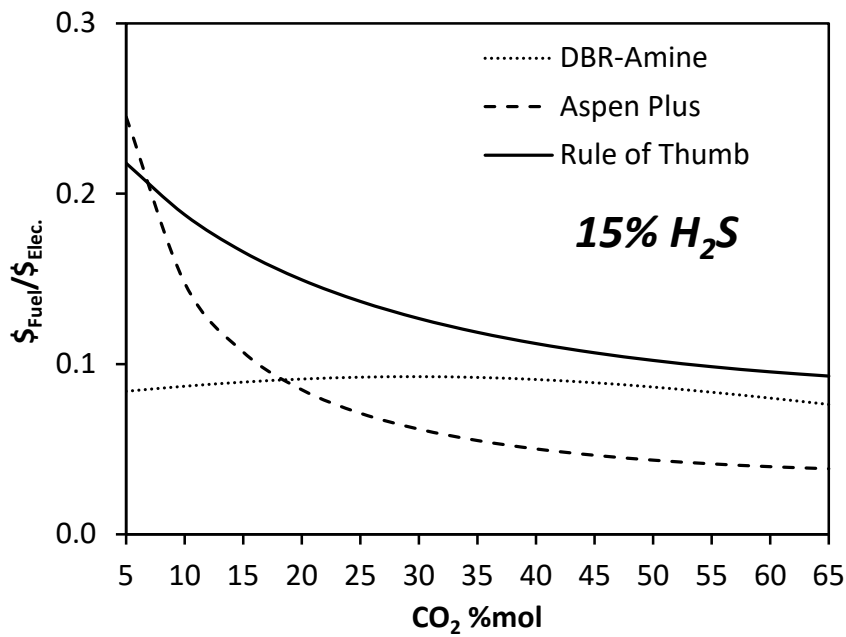

Figure 13. Breakeven point loci (Eq. (16)) obtained as functions of costs of gas and electricity for the three different methodologies adopted for the MDEA unit reboiler duty estimation at different mol% of H₂S and CO₂ in the raw natural gas stream.

If $\frac{\$Fuel}{\$Elec} > \frac{\$Fuel}{\$Elec}\Big|_{BEP}$ the low-temperature distillation process is more profitable than the MDEA

unit. The obtained results show that the increase of both CO₂ and H₂S contents favors the low-temperature distillation process. In the most conservative case, the breakeven point is obtained around 20 mol% of carbon dioxide without hydrogen sulfide. The trade-off value decreases with an increase of both the CO₂ and H₂S contents in the natural gas. From a practical point of view, it is quite impossible that the ratio $\frac{\$Fuel}{\$Elec}$ reaches 1, since natural gas can be used to produce energy.

Considering the results obtained with the use of the rule of thumb for the MDEA unit reboiler duty estimation and prices of gas and electricity, obtained from literature, for USA⁶⁶, Saudi Arabia⁶⁴ and Europe⁶⁷, it is possible to determine the breakeven-point between the two considered purification techniques for different geographic areas (Fig. (14)) and for different concentrations of acidic components in the raw gas feed.

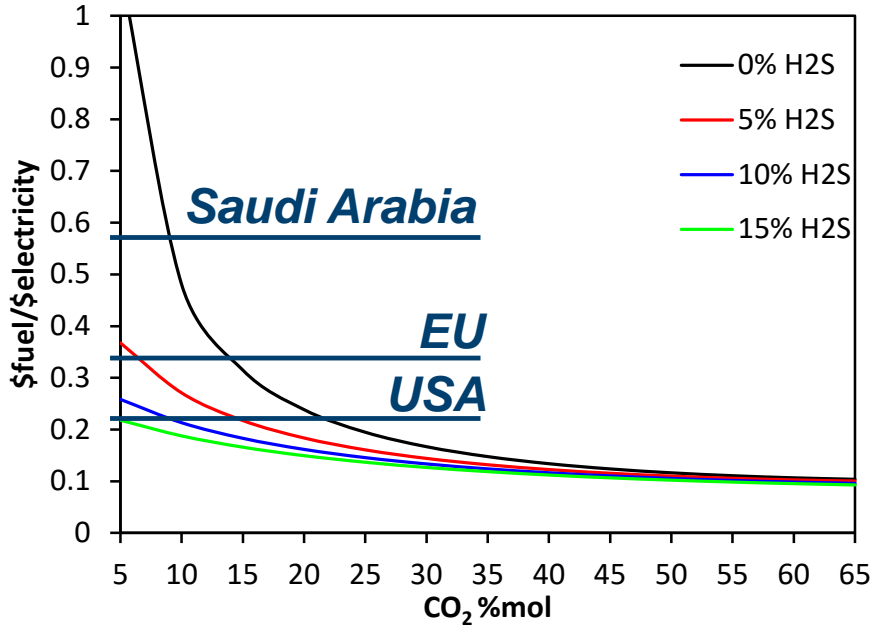

Figure 14. Variation of the breakeven-point between the proposed low-temperature distillation process and the traditional MDEA unit as function of CO₂ and H₂S contents in the raw gas feed and for different geographic areas.

For the case of Saudi Arabia, where energy is produced mainly from fossil fuels⁷⁰, the ratio between the price of fuel and the price of electricity is high (0.59) and close to the maximum theoretical value achievable according to purely thermodynamic considerations (Eqs. (17-18)) applied to the production of energy by means of a natural gas fired combined cycle power plant:

$$\frac{\$_{Elec}}{\$_{Fuel}} = \frac{\dot{m}_{Fuel} LHV_{Fuel} \$_{Fuel}}{W_{Elec}^{NET}} = \frac{\$_{Fuel}}{\eta_{CC}} \quad (17)$$

$$\frac{\$_{Fuel}}{\$_{Elec}} = \eta_{CC} \quad (18)$$

where the efficiency value is about 0.6⁷¹. In this geographic area, the low-temperature process is profitable in terms of energy expenses for the purification of natural gas streams having a CO₂ content higher than 8 mol% and for any concentration of hydrogen sulfide in the feed gas. This

result has been confirmed also in literature, when considering the application of other low-temperature purification processes in the Middle-East area⁷².

Considering regions as Europe or USA, where the energy mix is different, the ratio between the price of fuel and the price of electricity is lower and the breakeven-point occurs for higher concentrations of CO₂ in the feed gas, typically between 15 and 20 mol%.

It is possible to notice that the presence of hydrogen sulfide in the raw gas feed favors the profitability of the low-temperature process; moreover its effect on the breakeven-point is negligible above 35 mol% of carbon dioxide in the gas feed. The effect of hydrogen sulfide on the trade-off is important at low contents of carbon dioxide.

The provided graph (Fig. 14) allows to preliminarily determine the profitability of the new low-temperature distillation process as function of the acidic gases content in the natural gas and of the ratio between the price of fuel and the price of electricity, providing a simple tool useful to better select the process technology depending on the geographic area where the gas reserve is located.

Generally the low temperature distillation process can be considered suitable for applications to the processing of highly acid and or sour natural gas reserves.

The comparison between the low-temperature distillation process and the MDEA unit has been carried out, also, considering the amount of produced gas that has to be used to produce energy for the process. For the MDEA unit, the gas is burned to produce heat (Eq. (18)), while for the low-temperature distillation process to produce electricity (Eq. (19)) for driving the refrigeration cycle. A natural gas combined cycle has been assumed to produce electricity, while a natural gas fired boiler to produce heat. The comparison is made considering the fraction of the produced gas from the process required to produce these energy contributions.

$$Fuel_{Burned}^{MDEA} = \frac{\dot{Q}_{MDEA}}{LHV_{Fuel}\eta_{boiler}} \quad (18)$$

$$Fuel_{Burned}^{LT} = \frac{\dot{W}_{LT}}{COP_F LHV_{Fuel}\eta_{CC}} \quad (19)$$

Results are reported in Fig. 15.

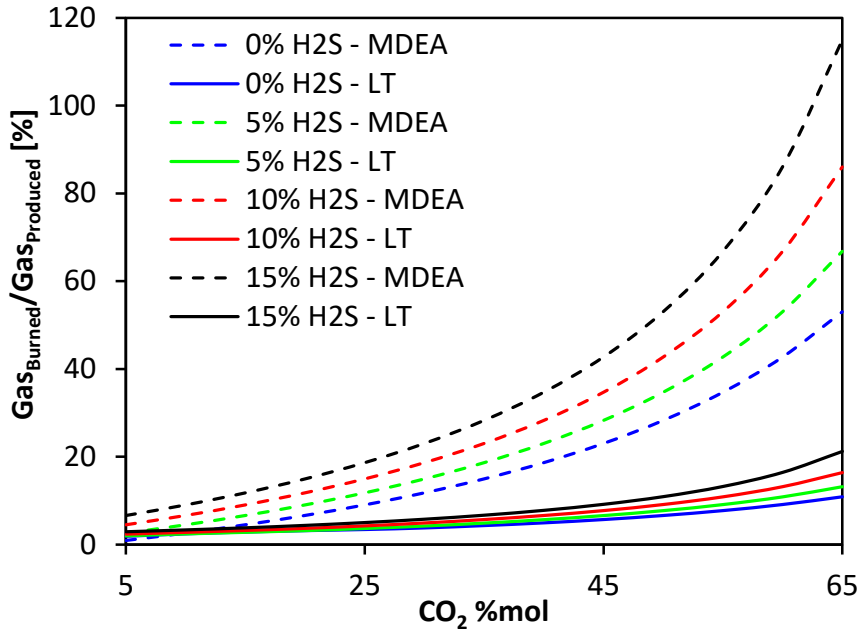

Figure 15. Comparison between the low-temperature distillation process and the MDEA unit in terms of percentage of produced gas required to produce energy for the process, considering the rule of thumb for the estimation of MDEA regenerator's reboiler duty.

It is possible to notice that the cross point between the two technologies occurs, when no H₂S is considered in the natural gas, for a CO₂ content of about 8-9 mol%. Under this value, for a H₂S-free natural gas, amine units require less fuel to produce energy, but above this point, amines consume more energy than the proposed low-temperature distillation process.

The proposed solution shows a great potential for applications at industrial level, since it allows energy savings and an effective profitability for highly sour and/or CO₂-rich natural gas reserves.

9. Conclusion

The continuous growth of the natural gas demand, together with the availability of low-quality gas reserves (with high CO₂ and/or H₂S contents), that were not considered suitable for the commercialization up to some years ago, requires efforts to study and develop new process solutions for the profitable exploitation of these kinds of sub-quality gas reserves, in order to meet the market demand reducing the overall production costs.

In this scenario, low-temperature purification processes have started to attract industries for this purpose. These technologies allow to reduce the energy expenses in comparison with more traditional purification units, that are energy intensive when applied for the treating of highly acid gases.

In this work, a new low-temperature distillation process has been studied and a techno-economic analysis has been carried out in order to establish its profitability, in terms of both energy savings and OPEX reductions, by comparison with more traditional MDEA purification units, that, nowadays, are largely used in the natural gas industry.

The patented low-temperature process is able to purify highly acid and/or sour gases meeting commercial specifications, without incurring in solid phase formations, performing the purification using traditional unit operations of the process industry. This aspect lends the studied solution a great simplicity. The process has been optimized by introducing the feed splitting technique. Significant energy savings have been achieved together with more flexibility for operations.

The comparison with MDEA units shows that the low-temperature process is more profitable for carbon dioxide contents above 10 mol%, depending on the geographic area where the gas reserve is located. The presence of hydrogen sulfide favors the profitability of the proposed

process solution respect to the one of MDEA units. The proposed low-temperature process allows significant energy savings considering, also, the amount of produced gas that has to be used to supply energy into the process. Moreover, the bottom stream containing the acidic compounds is liquid under pressure, suitable for Enhanced Oil Recovery (EOR) or acid gas reinjection applications, while traditional MDEA units discharge the acidic gases in gas phase at low pressure.

Moreover, a methodology has been studied to better assess the effect of the acidic gases contents in the raw natural gas and of the geographic area on the profitability of a new low-temperature purification process. The methodology is simple and can be generalized for the comparison with other processes for the natural gas sweetening, in order to better assess the most suitable purification technique according to the quality of the raw gas stream to be treated.

Abbreviations

BFW	Boiler Feed Water
C	Column for the process description or Cost if associated with a subscript
CE	Cost of Energy
COP	Coefficient of Performance
COP _r	Coefficient of Performance of the Refrigeration Cycle
EOR	Enhanced Oil Recovery
EoS	Equation of State
HP	High Pressure
LHV	Lower Heating Value
LP	Low Pressure
LT	Low-Temperature

MDEA	Methyldiethanolamine
NRTL	Non-Random Two Liquids
OPEX	Operating Expenses
P	Pressure
PR	Peng-Robinson
\dot{Q}	Heat Duty
SLE	Solid-Liquid Equilibrium
SLVE	Solid-Liquid-Vapor Equilibrium
SRK	Soave-Riedlich-Kwong
T	Temperature
UAE	United Arab Emirates
VLE	Vapor-Liquid Equilibrium
\dot{W}	Compression Work
x	Liquid phase mole fraction
y	Vapor phase mole fraction
$\$_{Steam}$	Price of Steam
$\$_{Elec}$	Price of Electricity
$\$$	Price
η_{boiler}	Boiler Efficiency
η_{CC}	Efficiency of a Natural Gas Fired Combined Cycle Power Plant

Corresponding Author

* To whom correspondence should be addressed. Tel.: +39 02 2399 4704. Fax: +39 02 7063

8173. E-mail: stefano.lange@polimi.it

Author Contributions

The manuscript was written through contributions of all authors. All authors have given approval to the final version of the manuscript.

ACKNOWLEDGMENT

The authors want to acknowledge dott. Fabio Brignoli for his contribution to the present work.

REFERENCES

- (1) BP. BP Energy Outlook 2035. BP, London, UK, 2014.
- (2) Carrol, J.; Foster, J. New Challenges & Solutions in Designing Large Sour Gas Projects. [Online] 2008, <http://www.fwc.com> (Accessed May 2014).
- (3) Burgers, W.J.F.; Northrop, P.S.; Khesghi, H.S.; Valencia, J.A. Worldwide Development Potential for Sour Gas. *Energy Proced.*, **2011**, *4*, 2178.
- (4) Pires, J.C.M.; Martins, F.G.; Alvim-Ferraz, M.C.M.; Simões, M. Recent developments on carbon capture and storage: an overview. *Chem. Eng. Res. Des.*, **2011**, *89*, 1446.
- (5) Haut, R.C.; Denton, R.D.; Thomas, E.R. Development and application of the controlled-freeze-zone process. *SPE Prod. Eng.*, **1989**, *August*, 265.
- (6) Parker, M. E.; Northrop, S.; Valencia, J.A.; Foglesong, R.E.; Duncan, W.T. CO₂ Management at ExxonMobil's LaBarge Field, Wyoming, USA. *Energy Proced.*, **2011**, *4*, 5455.

- (7) Northrop, P.S.; Valencia, J.A. The CFZTM Process: a Cryogenic Method for Handling High-CO₂ and H₂S Gas Reserves and Facilitating Geosequestration of CO₂ and Acid Gases. *Energy Proced.*, **2009**, *1*, 171.
- (8) Valencia, J.A.; Denton, R.D. Method and Apparatus for Separating Carbon Dioxide and Other Acid Gases from Methane by the Use of Distillation and a Controlled Freeze Zone. US Patent 4533372, August 6, 1985.
- (9) Valencia, J.A.; Victory, D.J. Method and Apparatus for Cryogenic Separation of Carbon Dioxide and Other Acid Gases from Methane. US Patent 4923493, May 8, 1990.
- (10) Valencia, J.A.; Victory, D.J. Bubble Cap Tray for Melting Solids and Method for Using Same. US Patent 5265428, November 30, 1993.
- (11) Holmes, A.S.; Price, B.C.; Ryan, J.M.; Styring, R.E. Pilot Tests Prove Out Cryogenic Acid–Gas/Hydrocarbon Separation Processes. *Oil Gas J.*, **1983**, *27*, 85.
- (12) Holmes, A.S.; Ryan, J.M. Cryogenic Distillative Separation of Acid Gases from Methane. US Patent 4318723, March 9, 1982.
- (13) Holmes, A.S.; Ryan, J.M. Distillative Separation of Carbon Dioxide from Light Hydrocarbons. US Patent 4350511, September 21, 1982.
- (14) Clodic, D.; Younes, M. A new Method for CO₂ Capture: Frosting CO₂ at Atmospheric Pressure. In: *Sixth International Conference on Greenhouse Gas Control Technologies GHGT6* Proceedings of the 6th International Conference on Greenhouse Gas Control Technologies, Kyoto, Japan, 1 – 4 October **2002**, 155, Gale, J.; Kaya, Y., Eds.; Elsevier: Amsterdam, 2003.

- (15) Pellegrini, L.A. Process for the Removal of CO₂ from Acid Gas. WO Patent 2014/054945A2, April 10, 2014.
- (16) Berstad, D.; Anantharaman, R.; Neska P. Low-Temperature CO₂ Capture Technologies- Applications and Potential. *Int. J. Refrig.*, **2013**, *36*, 1403.
- (17) Tuinier, M.J.; van Sint-Annaland, M. Biogas Purification Using Cryogenic Packed-Bed Technology. *Ind. Eng. Chem. Res.*, **2012**, *51*, 5552.
- (18) Chakma, A., CO₂ Capture Processes-Opportunities for Improved Energy Efficiencies. *Energy Convers. Mgmt*, **1997**, *38*, S51.
- (19) <http://www.energy.eu> (Accessed May 2013).
- (20) <http://www.igu.org> (Accessed May 2013).
- (21) <http://www.eia.gov> (Accessed May 2013).
- (22) <http://www.electricity.ca> (Accessed May 2013).
- (23) Soave, G. S.; Gamba, S.; Pellegrini, L.A.; Bonomi, S. Feed Splitting Technique in Cryogenic Distillation. *Ind. Eng. Chem. Res.*, **2006**, *45(16)*, 5761.
- (24) Rufford, T. E.; Smart, S.; Watson, G. C. Y.; Graham, B. F.; Boxall, J.; Diniz da Costa, J. C.; May, E. F. The Removal of CO₂ and N₂ from Natural Gas: a Review of Conventional and Emerging Process Technologies. *J. Petrol. Sci. Eng.*, **2012**, *94-95*, 123.
- (25) Mokhatab, S.; Poe, W. A.; Speight, J. G. *Handbook of Natural Gas Transmission and Processing*. Gulf Professional Publishing: Burlington, MA, USA, 2006.

- (26) Moore, P.J.; Spitler, R.W. Hydrogen Sulfide Measurement and Detection. *Proced. American School of Gas Measurement Technology*. [Online] 2003, 118-123, <http://asgmt.com/paper/> (Accessed February 2013).
- (27) Tecnimont, Maire Tecnimont, Milan, Italy. Personal communication, 2013.
- (28) Kohl, A. L.; Nielsen, R. B. *Gas Purification*, Fifth ed. Gulf Publishing Company: Houston, TX, 1997.
- (29) Addington, L.; Ness, C. An Evaluation of General “Rules of Thumb” in Amine Sweetening Unit Design and Operation. *Bryan Research and Engineering*. [Online] 2010. <http://www.bre.com> (Accessed May 2013).
- (30) AspenTech, Copyright® 1981-2010. Aspen Physical Property System. Physical Property Methods and Model, Handbook of AspenONE™. AspenONE Documentation: AspenTech, 2010.
- (31) Aspen Plus®, Copyright® 1981-2010, Aspen Technology. AspenONE Documentation: AspenTech, 2010.
- (32) AspenTech, Copyright® 1981-2010. Rate-Based Model of the CO₂ Capture Process by MDEA Using Aspen Plus, AspenONE Documentation: AspenTech, 2010.
- (33) Chen, C.C.; Britt, H.I.; Boston, J.F.; Evans, L.B. Extension and Application of the Pitzer Equation for Vapor-Liquid Equilibrium of Aqueous Electrolyte Systems with Molecular Solutes. *AIChE J.*, **1979**, 25, 820.
- (34) Chen, C.C.; Britt, H.I.; Boston, J.F.; Evans, L.B. Local Composition Model for Excess Gibbs Energy of Electrolyte Systems. *AIChE J.*, **1982**, 28, 588.

- (35) Chen, C.C.; Evans, L.B. A Local Composition Model for the Excess Gibbs Energy of Aqueous Electrolyte System. *AIChE J.*, **1986**, *32*, 444.
- (36) Mock, B.; Evans, L.B.; Chen, C.C. Thermodynamic Representation of Phase Equilibria of Mixed-Solvent Electrolyte Systems. *AIChE J.*, **1986**, *32*, 1655.
- (37) Soave, G. Equilibrium constants from a modified Redlich-Kwong equation of state. *Chem. Eng. Sci.*, **1972**, *27*, 1197.
- (38) Langè, S.; Quadri, C. Il Processo di Assorbimento di Gas Acidi con Soluzioni Acque di Metildietanolammina. Master of Science thesis, Politecnico di Milano, Milano, Italy, December 2011.
- (39) Moioli, S.; Pellegrini, L.A.; Picutti, B.; Vergani, P. Improved Rate-Based Modeling of H₂S and CO₂ Removal by Methyldiethanolamine Scrubbing. *Ind. Eng. Chem. Res.*, **2013**, *52*(5), 2056.
- (40) Moioli, S. Simulation of the Gas Purification Process with Aqueous Solutions of Amines. PhD Thesis, Politecnico di Milano, Milano, Italy, March 2013.
- (41) <http://www.mairetecnimont.com/it/business/progetti/impianto-di-processo-di-habshan-5-abu-dhabi-1> (Accessed June 2013).
- (42) De Guido, G.; Langè, S.; Moioli, S.; Pellegrini, L. A. Thermodynamic Method for the Prediction of Solid CO₂ Formation from Multicomponent Mixtures. *Process Saf. Environ. Prot.*, **2014**, *92*, 70.
- (43) De Guido, G.; Langè, S.; Moioli, S.; Pellegrini, L. A. Calculation of CO₂ Freezing Points in Mixtures Using SRK and PR EoSs. *2nd International Symposium on Energy Challenges*

and Mechanics. Aberdeen, Scotland, UK, August 19-21, 2014. Accepted for Publication on 16th May 2014.

- (44) Peng, D.-Y.; Robinson, D.B. A New Two-Constant Equation of State. *Ind. Eng. Chem. Fundam.*, **1976**, 15, 59.
- (45) Donnelly, H. G.; Katz, D. L. Phase Equilibria in the Carbon Dioxide–Methane System. *Ind. Eng. Chem.*, **1954**, 46, 511.
- (46) Davis, J. A.; Rodewald, N.; Kurata, F. Solid–Liquid–Vapor Phase Behavior of the Methane–Carbon Dioxide System. *AIChE J.*, **1962**, 8, 537.
- (47) Im, U. K.; Kurata, F. Phase Equilibrium of Carbon Dioxide and Light Paraffins in Presence of Solid Carbon Dioxide. *J. Chem. Eng. Data*, **1971**, 16(3), 295.
- (48) Shen, T.; Gao, T.; Lin, W.; Gu, A. Determination of CO₂ Solubility in Saturated Liquid CH₄ + N₂ and CH₄ + C₂H₆ Mixtures above Atmospheric Pressure. *J. Chem. Eng. Data*, **2012**, 57, 2296.
- (49) Cheung, H.; Zander, E. H. Solubility of Carbon Dioxide and Hydrogen Sulfide in Liquid Hydrocarbons at Cryogenic Temperatures. *Chem. Eng. Symp. Ser.*, **1968**, 64(88), 34.
- (50) Boyle, G. J. Shell Res. LTD. In *Knapp H., Teller M., Langhorst R. Solid–Liquid Equilibrium Data Collection; Vol. VIII, part 1, Chemistry Data Series, Volume VIII, part 1*; Dechema: Frankfurt, Germany, 1987.
- (51) Brewer, J.; Kurata, F. Freezing Points of Binary Mixtures of Methane. *AIChE J.*, **1958**, 4(31), 317.

- (52) Sterner, C. J. Phase Equilibria in the CO₂–Methane Systems. *Adv. Cryog. Eng.*, **1961**, 6, 467.
- (53) Knapp H., Teller M., Langhorst R. *Solid–Liquid Equilibrium Data Collection; Vol. VIII, part 1*, Chemistry Data Series, Volume VIII, part 1; Dechema: Frankfurt, Germany, 1987.
- (54) Streich, M. N₂ Removal from Natural Gas. *Hydrocarbon Process.*, **1970**, 49, 86.
- (55) Voss, G. Ph.D. Thesis, Technical University of Berlin, Berlin, Germany, 1975.
- (56) Brady, C. J.; Cunningham, J. R.; Wilson, G. M. Water-Hydrocarbon Liquid-Liquid-Vapor Equilibrium Measurements in 530 Degrees F. GPA Research Report, RR-62; Tulsa, OK, 1982.
- (57) Sparks, K.A.; Sloan, E.D. Water Content of NGL in Presence of Hydrates, GPA Research Report, RR-71; Tulsa, OK, 1983.
- (58) Riva, M.; Campestrini, M.; Toubassy, J.; Clodic, D.; Stringari, P. Solid–Liquid–Vapor Equilibrium Models for Cryogenic Biogas Upgrading. *Ind. Eng. Chem. Res.*, **2014**, 53(44), 17506.
- (59) AspenTech, Copyright® 1981-2010. NIST TDE in Aspen Properties Databank®, Aspen Technology, Inc., Burlington, Massachusetts, USA, 2010.
- (60) Sobocinski, D. P.; Kurata, F. Heterogeneous Phase-Equilibria of the Hydrogen Sulfide-Carbon Dioxide System. *AIChE J.*, **1959**, 5 (4), 545.
- (61) Langè, S.; Pellegrini, L. A.; Stringari, P.; Coquelet, C. Experimental Determination of the Solid-Liquid-Vapor Locus for the CH₄-CO₂-H₂S System and Application to the Design of

- a New Low-Temperature Distillation Process for the Purification of Natural Gas. In: *94th Annual GPA Convention*, Proceedings of the 94th Annual GPA Conference, San Antonio, TX, USA, April 12-15, 2015.
- (62) Perry, R.H.; Green, D.W. *Perry's Chemical Engineers' Handbook*, 7th edition; McGraw-Hill: New York, NY, USA, 1999.
- (63) Cleaver Brooks. Boiler Efficiency Guide. [Online] 2010. <http://www.cleaver-brooks.com/Reference-Center/Insights/Boiler-Efficiency-Guide.aspx> (Accessed May 2013).
- (64) Pellegrini, L.A.; Soave, G.; Gamba, S.; Langè, S. Economic Analysis of a Combined Energy-Methanol Production Plant. *Appl. Energy*, **2011**, *88(12)*, 4891.
- (65) U.S. Department of Energy How to Calculate the True Cost of Steam. [Online] 2003. <https://www1.eere.energy.gov> (Accessed May, 2013).
- (66) International Energy Agency Key World Energy Statistics. [Online] 2012. <http://www.iea.org/publications/freepublications/publication/kwes.pdf> (Accessed May 2013).
- (67) Europe's Energy Portal. <http://www.energy.eu> (Accessed, May 2013).
- (68) International Gas Union Wholesale Gas Price Formation 2012 - A global review of drivers and regional trends. [Online 2012]. <http://www.igu.org> (Accessed May 2013).
- (69) Langè, S. The Purification of Natural Gas by Means of a New Low Temperature Distillation Process. PhD Thesis, Politecnico di Milano, Milan, Italy, March 2015.

(70) <https://www.iea.org/ieaenergy/issue7/saudi-energy-mix-renewables-augment-gas.html>
(Accessed March, 2015).

(71) Kehlhofer, R.; Hanneman, F.; Stirnimann, F.; Rukes, B. Combined-Cycle Gas & Steam Turbine Power Plant; Pennwell Corporation: Tulsa, OK, USA, 2009.

(72) Denton, R.D.; Mart, C. J.; Kelman, S. D.; Valencia, J. A. Controlled Freeze Zone™ Technology Available for the Commercialization of Middle East Sour Gas Resources. In: *SOGAT (Sour Oil and Gas Advanced Technology) Conference*, Proceedings of the Sour Oil and Gas Advanced Technology Conference, Abu Dhabi, UAE, March 23-27, 2014.